



---

# Evergreen Valley College 2025 Updated Facilities Master Plan

Draft Environmental Impact Report  
SCH No. 2000112004

---

February 2013

## Volume II - Appendices

**Prepared for:**  
San José/Evergreen Community College District,  
4750 San Felipe Road,  
San José, California 95135

**Prepared By:**  
Impact Sciences, Inc.  
555 12th Street, Suite 1650  
Oakland, California 94607

**Evergreen Valley College  
2025 Updated Facilities Master Plan  
Draft Environmental Impact Report**

**SCH No. 2000112004**

**Volume II  
Appendices**

**Prepared for:**

San José/Evergreen Community College District  
4750 San Felipe Road  
San José, California 95135

**Prepared by:**

Impact Sciences, Inc.  
555 12th Street  
Oakland, California 94607

**February 2013**

# TABLE OF CONTENTS

Section	Page
1.0 INTRODUCTION.....	1.0-1
2.0 EXECUTIVE SUMMARY.....	2.0-1
3.0 PROJECT DESCRIPTION.....	3.0-1
4.0 ENVIRONMENTAL IMPACT ANALYSIS.....	4.0-1
4.1 Aesthetics.....	4.1-1
4.2 Air Quality.....	4.2-1
4.3 Biological Resources.....	4.3-1
4.4 Geology and Soils.....	4.4-1
4.5 Greenhouse Gas Emissions.....	4.5-1
4.6 Hydrology and Water Quality.....	4.6-1
4.7 Land Use and Planning.....	4.7-1
4.8 Noise.....	4.8-1
4.9 Public Services.....	4.9-1
4.10 Transportation and Traffic.....	4.10-1
4.11 Utilities and Service Systems.....	4.11-1
5.0 ALTERNATIVES.....	5.0-1
6.0 OTHER CEQA CONSIDERATIONS.....	6.0-1
7.0 LIST OF PREPARERS.....	7.0-1

**Appendices (CD inside back cover)**

1.0	Notice of Preparation, Initial Study, and Scoping Comments Notice of Preparation Initial Study Scoping Comments
4.2	Air Quality Modeling Output
4.5	Greenhouse Gas Modeling Output
4.8	Noise Modeling Output
4.10	Traffic Technical Report

**APPENDIX 1.0**

---

**Notice of Preparation, Initial Study, and Scoping Comments**



State of California  
Office of Planning and Research  
1400 Tenth Street  
Sacramento, CA 95814

**NOTICE OF PREPARATION  
ENVIRONMENTAL IMPACT REPORT**

**Project Title:** Evergreen Valley College 2025 Facilities Master Plan

**Lead Agency:** San Jose/Evergreen Community College District

**Project Location:** Evergreen Valley College  
4750 San Felipe Road, San Jose, CA 95135

**County:** Santa Clara County

**Contact Person:** Mr. Douglas Smith  
Vice Chancellor of Administrative Services  
4750 San Felipe Road  
San José, CA 95135

The San Jose/Evergreen Community College District (SJECCD) proposes to adopt the 2025 Facilities Master Plan (FMP) for the Evergreen Valley College campus in San Jose, California. The plan translates the program space needs established in the 2025 Educational Master Plan (EMP) for the campus into physical facilities on campus. According to the 2025 EMP for the EVC campus, total enrollment on campus is expected to reach approximately 14,850 students by 2025, which equates to 9,100 Full-Time Equivalent (FTE) students. Based on these projections, future program needs on the campus total approximately 355,175 square feet of space.

The 2025 FMP involves the reorganization of campus facilities and the reconfiguration of campus access and circulation. Facility recommendations contained in the plan include demolition/removal of existing buildings on campus; construction of new buildings; and renovation of existing buildings on campus to meet the future program needs.

**Environmental Review and Comment**

The SJECCD will be the Lead Agency and will prepare an EIR for the proposed project. An Initial Study has been prepared in accordance with the California Environmental Quality Act (CEQA) and the State CEQA Guidelines to identify potential environmental impacts that will be addressed in the EIR (see Attachment A). The attached Initial Study also includes a more detailed description of the proposed project. At this time, it is anticipated that the EIR will address environmental impacts in the following resource areas: aesthetics, air quality, biological resources, geology and soils, greenhouse gas emissions, hydrology and water quality, land use

and planning, noise, public services (fire and police), transportation and traffic, and utilities and service systems.

The SJECCD will hold a public scoping meeting for the EVC 2025 Facilities Master Plan EIR on August 1, 2012. The public scoping meeting will be held in the Appi Mishra Room of the Library/Educational Technology Center (Learning Resource Center) on the EVC campus from 7:00 PM to 9:00 PM.

A copy of this NOP will be placed on the campus' website at [sjeccd.edu](http://sjeccd.edu).

We request your views as to the scope and contents of the EIR for the proposed project. This NOP is being circulated for 30 days from July 10, 2012 through August 9, 2012. Your response must be received no later than 5:00 PM on August 9, 2012. Your name should be included with your response. Please send your response to the attention of Douglas Smith at the address noted above or via email to the following address: [douglas.smith@sjeccd.edu](mailto:douglas.smith@sjeccd.edu). Email responses must also be received no later than 5:00 PM on August 9, 2012.

If you have any questions regarding this NOP, please contact Douglas Smith at the above address or via email at [douglas.smith@sjeccd.edu](mailto:douglas.smith@sjeccd.edu).

Signature: \_\_\_\_\_

Douglas Smith

Vice Chancellor of Administrative Services

San Jose/Evergreen Community College District

Date: \_\_\_\_\_

7/9/12

Attachment A: Initial Study





# EVERGREEN VALLEY COLLEGE 2025 FACILITIES MASTER PLAN

Draft Initial Study

The following Initial Study has been prepared in compliance with CEQA.

**Prepared For:**

San José/Evergreen Community College District  
4750 San Felipe Road  
San José, California 95135  
Contact: Mr. Douglas Smith, Vice Chancellor of Administrative Services

**Prepared By:**

Impact Sciences, Inc.  
555 12<sup>th</sup> Street, Suite 1650  
Oakland, California 94607  
(510) 267-0494  
Contact: Elizabeth Purl

**July 2012**

# TABLE OF CONTENTS

Section	Page
INTRODUCTION .....	1
Initial Study .....	1
Anticipated Project Approvals .....	1
Public and Agency Review .....	1
Organization of the Initial Study .....	2
I. PROJECT INFORMATION .....	3
II. PROJECT LOCATION AND DESCRIPTION .....	4
III. ENVIRONMENTAL FACTORS POTENTIALLY AFFECTED .....	15
IV. DETERMINATION: .....	16
V. EVALUATION OF ENVIRONMENTAL IMPACTS .....	17
1. Aesthetics .....	18
2. Agriculture and Forestry Resources .....	20
3. Air Quality .....	22
4. Biological Resources .....	24
5. Cultural Resources .....	27
6. Geology and Soils .....	30
7. Greenhouse Gas Emissions .....	33
8. Hazards and Hazardous Materials .....	34
9. Hydrology and Water Quality .....	38
10. Land Use and Planning .....	42
11. Mineral Resources .....	43
12. Noise .....	44
13. Population and Housing .....	46
14. Public Services .....	47
15. Recreation .....	49
16. Transportation/Traffic .....	51
17. Utilities and Service Systems .....	53
18. Mandatory Findings of Significance .....	55
VI. SUPPORTING INFORMATION SOURCES .....	56
VII. INITIAL STUDY PREPARERS .....	58

# LIST OF FIGURES

Figure		Page
1	Regional and Site Location.....	8
2	Evergreen Valley College 2025 Facilities Master Plan.....	9
3	Recommended Demolition/Removal Plan.....	10
4	Recommended Vehicular Circulation Plan.....	11
5	Recommended Pedestrian Circulation Plan.....	12
6	Recommended Landscape Improvements.....	13
7	Surrounding Land Uses.....	14

## INTRODUCTION

### Initial Study

Pursuant to Section 15063 of the *California Environmental Quality Act (CEQA) Guidelines* (Title 14, California Code of Regulations, Sections 15000 et seq.), an Initial Study is a preliminary environmental analysis that is used by the lead agency as a basis for determining whether an Environmental Impact Report (EIR), a Mitigated Negative Declaration, or a Negative Declaration is required for a project. The *State CEQA Guidelines* require that an Initial Study contain a project description, description of environmental setting, identification of environmental effects by checklist or other similar form, explanation of environmental effects, discussion of mitigation for significant environmental effects, evaluation of the project's consistency with existing, applicable land use controls, and the names of persons who prepared the study.

The purpose of this Initial Study is to evaluate the potential environmental impacts of the proposed Evergreen Valley College (EVC) 2025 Facilities Master Plan (FMP) and to determine what level of additional environmental review, if any, is appropriate. As shown in the Determination in **Section IV** of this document and based on the analysis contained in this Initial Study, the San José/Evergreen Community College District has determined that the proposed EVC 2025 FMP could result in potentially significant impacts; therefore, preparation of an EIR is appropriate.

### Anticipated Project Approvals

The San José/Evergreen Community College District (SJECCD) will prepare an EIR that fully evaluates the environmental effects associated with the implementation of the proposed 2025 FMP. Necessary project approvals are anticipated to include, but are not limited to, consideration of the following by the SJECCD Board of Trustees (anticipated in spring/summer 2012):

- Certification of the EVC 2025 FMP EIR and
- Approval of the proposed EVC 2025 FMP.

### Public and Agency Review

The Notice of Preparation (NOP) for the EIR and this Initial Study will be circulated for public and agency review from July 10, 2012 through August 9, 2012. Copies of the Initial Study are available during normal operating hours at the District office at the address below and online at [sjeccd.edu](http://sjeccd.edu). Comments on the NOP/Initial Study must be received by 5:00 PM on August 9, 2012. They may be e-mailed to [douglas.smith@sjeccd.edu](mailto:douglas.smith@sjeccd.edu) or sent to:

San José/Evergreen Community College District  
Administrative Services  
4750 San Felipe Road  
San José, California 95135  
Attn: Mr. Douglas Smith, Vice Chancellor

A public scoping meeting for the EVC 2025 FMP EIR will be held on Wednesday, August 1, 2012 on the EVC campus at 3095 Yerba Buena Road, San Jose, from 7:00 PM to 9:00 PM. The public and agency review period for the Draft EIR is anticipated to commence in autumn 2012.

### **Organization of the Initial Study**

This Initial Study is organized into the following sections.

- **Section I – Project Information:** provides summary background information about the proposed project, including project location, lead agency, and contact information.
- **Section II – Project Location and Description:** includes a description of the proposed project, including the need for the project, the project’s objectives, and the elements included in the project.
- **Section III – Environmental Factors Potentially Affected:** identifies what environmental resources, if any, would involve at least one significant or potentially significant impact that cannot be reduced to a less than significant level.
- **Section IV – Determination:** indicates whether impacts associated with the proposed project would be significant, and what, if any, additional environmental documentation is required.
- **Section V – Evaluation of Environmental Impacts:** contains the Environmental Checklist form for each resource. The checklist is used to assist in evaluating the potential environmental impacts of the proposed project. This section also presents an explanation of all checklist answers.
- **Section VI – Supporting Information Sources:** lists references used in the preparation of this document.
- **Section VII – Initial Study Preparers:** lists the names of individuals involved in the preparation of this document.

## I. PROJECT INFORMATION

1. Project title:

Evergreen Valley College 2025 Facilities Master Plan

2. Lead agency name and address:

San José/Evergreen Community College District Board of Trustees  
4750 San Felipe Road  
San José, California 95135

3. Contact person and phone number:

Mr. Douglas Smith  
Vice Chancellor, Administrative services

(408) 270-6428  
douglas.smith@sjeccd.edu

4. Project location:

Evergreen Valley College  
3095 Yerba Buena Road  
San José, California 95135

5. Project sponsor's name and address:

San José/Evergreen Community College District  
4750 San Felipe Road  
San José, California 95135

6. Custodian of the administrative record for this project (if different from response to **item 3** above.):

Same as above.

## II. PROJECT LOCATION AND DESCRIPTION

### 1. Description of the Project:

**Location:** The EVC campus is located at 3095 Yerba Buena Road in east-central San José in Santa Clara County. The location of the campus within Santa Clara County and the City of San José is shown in **Figure 1, Regional and Site Location**. The campus is near the eastern City boundary and is bounded by San Felipe Road to the west, Yerba Buena Road to the south, Montgomery Hill Park to the east, and Falls Creek Drive to the north. The campus encompasses about 165.5 acres. The northern portion of campus consists of a hillside area while the southern portion of the campus is flat and is referred to as the “plains.”

**Project Need:** The 2025 FMP translates the program space needs established in the EVC 2025 Educational Master Plan into physical facilities on the campus. According to the 2025 Educational Master Plan for the EVC campus, total enrollment on campus is expected to reach approximately 14,850 students by 2025, which equates to 9,100 Full-Time Equivalent (FTE) students (FTES). Based on these projections, future program needs on the campus total approximately 355,175 square feet of space, calculated based on allowable standards referenced in the California Code of Regulations Title 5. The amount of space required on the campus takes into account of all facility needs of the campus – academic space as well as space for support services. The 2025 Education Master Plan determined that EVC does not show any significant need for additional space through the year 2025, although there are needs in certain specific space categories.

**Project Characteristics:** The 2025 FMP involves reorganization of campus facilities and reconfiguration of campus access and circulation. The proposed 2025 FMP for the EVC campus is depicted in **Figure 2, Evergreen Valley College 2025 Facilities Master Plan**. The recommendations contained in the 2025 FMP address the current and projected needs of the campus through 2025.

Facility recommendations contained in the 2025 FMP include (1) the demolition/removal of existing building on campus; (2) the construction of new buildings on campus; and (3) the renovation of existing buildings on campus to meet the future programs needs as outlined in 2025 Educational Master Plan. A description of each of these elements is provided below.

#### *Recommended Demolition/Removal*

The 2025 FMP identifies several buildings for demolition/removal to eliminate non-functioning space and replace the oldest and most aged facilities with new facilities. Facilities identified by the 2025 FMP for demolition/removal include Cluster Acacia, Cluster Roble, Racquetball Courts, and all portable buildings. The location of each of these facilities is shown in **Figure 3, Recommended Demolition/Removal Plan**.

#### *New Construction Projects*

Descriptions of new construction projects planned on the EVC campus are organized into groups based on campus location. The order of the projects does not reflect priority order or a recommended sequence of development. Preliminary phasing plans will be developed following the completion of the 2025 FMP and will be tied to availability of funding.

**Math/Science Complex** – The new Math/Science Complex would be part of a South Campus Development project and would provide new instructional space and be coordinated with the removal of the aging Cluster Acacia. The multi-story complex would include dedicated labs and flexible classroom to support the science and math programs. The proposed location, to the south of the Gullo Student Center building (Gullo I) in the center of the campus, ties into the lower level of the Student Center and would bring activity to an underutilized area of the campus. The new outdoor gathering space would be framed by buildings to create connections to the “plains” area of the campus.

**Automotive Technology** – The Automotive Technology Building would replace aging facilities that are currently part of Cluster Acacia. Its new northwest campus location would also have the “Hillside” as a backdrop and be located near the new parking lot with photovoltaic canopies.

**General Education Building** – The General Education Building would be part of a South Campus Development project and would provide replacement classroom space as the aging cluster buildings are removed from the campus. The proposed location, adjacent to the Math/Science Complex, would help to define the new outdoor areas to the south of Gullo I. This multi-story instructional building would include multi-purpose, flexible instructional space to support a variety of disciplines.

**GED/Engineering/Language Arts/Social Science** – This facility would be located in the northwest portion of campus on the site vacated by the demolition of cluster Roble. It would anchor the Village Walk West, with the “Hillside” as a backdrop, and would help redefine the western edge of the campus. This multi-story instructional building would include multi-purpose, flexible, instructional space to support general education, engineering, language arts, and social science.

**Fitness Center** – The proposed 7,000 square-foot Fitness Center would be part of a South Campus Development project and is proposed to be located to the south of the Physical Education building, adjacent to the athletic fields. The facility is in close proximity to the Fitness Walk and operable windows would provide broad views to the grass sports field (the “Plains”). This may be the first LEED® project on the campus.

### ***Renovation Projects***

The 2025 FMP recommends renovations to several buildings. A description of renovation projects planned on the EVC campus is provided below. The order of the projects does not reflect priority order or a recommended sequence of development. In addition to the projects highlighted below, the 2025 FMP recommends the renovation of all other existing campus facilities as required.

**Central Plant/Campus Police Building** – During the planning process, the Central Plant/Campus Police Building was analyzed in order to determine the best course of action for the future. Both renovation and replacement facilities were considered, but ultimately the decision was made to renovate the existing Central Plant/Campus Police Building in its current location. This decision was considered to be the most economical and would save over \$8 million compared to the cost of new facilities. Mechanical equipment in the Central Plant would be upgraded, electrical service equipment would be replaced, and staff areas would be improved. The District’s Police Department, which operates from the Campus Police Building, would expand to allow more efficient operations and provide a secure environment responsive to current District needs. The exterior of the building would be improved to reflect a more consistent campus architectural



theme and to provide a more recognizable presence for Campus Police.

**Administration/Student Services Center** –The 2025 FMP recommends that the Administration/Student Services Center be studied in conjunction with the Admission & Records (A&R) building with the goal of developing a long-range plan that addresses both current budget and staffing reductions, which will potentially affect the configuration and uses of the building, and the long-term needs of the College.

**Admissions & Records Building** – A&R has also been identified as a building requiring operational-related renovations. The 2025 FMP recommends that the A&R building be studied in conjunction with the Administration/Student Services Center with the goal of developing a long-range plan that addresses both current budget and staffing reductions, which will potentially affect the configuration and uses of the building, and the long-term needs of the College.

**Gullo I** – The 2025 FMP recommends that Gullo I, the Student Center, be reconfigured to provide additional space for the Student Activities Center. This would consolidate most student activities in one location. There is a potential under the FMP to relocate the bookstore; further study of this issue would be needed.

**Gullo II** – Gullo II is primarily used as a multi-functional event and community room. It has a capacity to hold 250-300 people; however, acoustically it functions poorly. The 2025 FMP recommends that the location of a new large multi-purpose event room be studied and that this function vacate Gullo II. The 2025 FMP further recommends that this space be reprogrammed and renovated to house a new café and informal student gathering area.

### ***Site Improvements***

In addition to the recommendations for facilities, a series of site improvement recommendations were identified in the 2025 FMP, consisting of a recommended vehicular circulation plan, a recommended pedestrian circulation plan, and recommended landscape improvements. These are show in **Figure 4, Recommended Vehicular Circulation Plan; Figure 5, Recommended Pedestrian Circulation Plan; and Figure 6, Recommended Landscape Improvements.**

2. Project objectives:

The primary objective of the 2025 FMP is to provide the necessary facilities to accommodate the planned 2025 student population for the EVC campus.

3. Surrounding land uses and environmental setting:

The campus is in a suburban setting that has experienced substantial commercial and residential development in the past several years. Nearby uses include residential uses to the north beyond Evergreen Creek, to the west beyond Thompson Creek, and to the south beyond Yerba Buena Creek; Falls Creek Park to the north; Evergreen Park and a church to the south; Montgomery Hill Park and undeveloped lands to the east; and an assisted-living facility to the west. **Figure 7, Surrounding Land Uses,** depicts the location of these land uses in relation to the EVC campus.

4. Discretionary approval authority and other public agencies whose approval is required:

As the public entity principally responsible for approving or carrying out the proposed project, the SJECCD is the Lead Agency under CEQA and is responsible for reviewing and certifying the adequacy of the environmental document and approving the proposed project. The SJECCD Board of Trustees would make the decision on project approval.

The project may also require approval from the following public agencies:

- Division of the State Architect (DSA) for buildings, handicap accessibility, fire and life safety;
- City of San José Public Works and Traffic;
- City of San José Fire Department for site access and fire hydrants/water pressure;
- Santa Clara County Water District; and
- Santa Clara Valley Water District.



SOURCE: Google Earth – September 2011

FIGURE 1

Regional and Site Location





SOURCE: Evergreen Valley College 2025 Facilities Master Plan – November 2011

FIGURE 2

Evergreen Valley College 2025 Facilities Master Plan

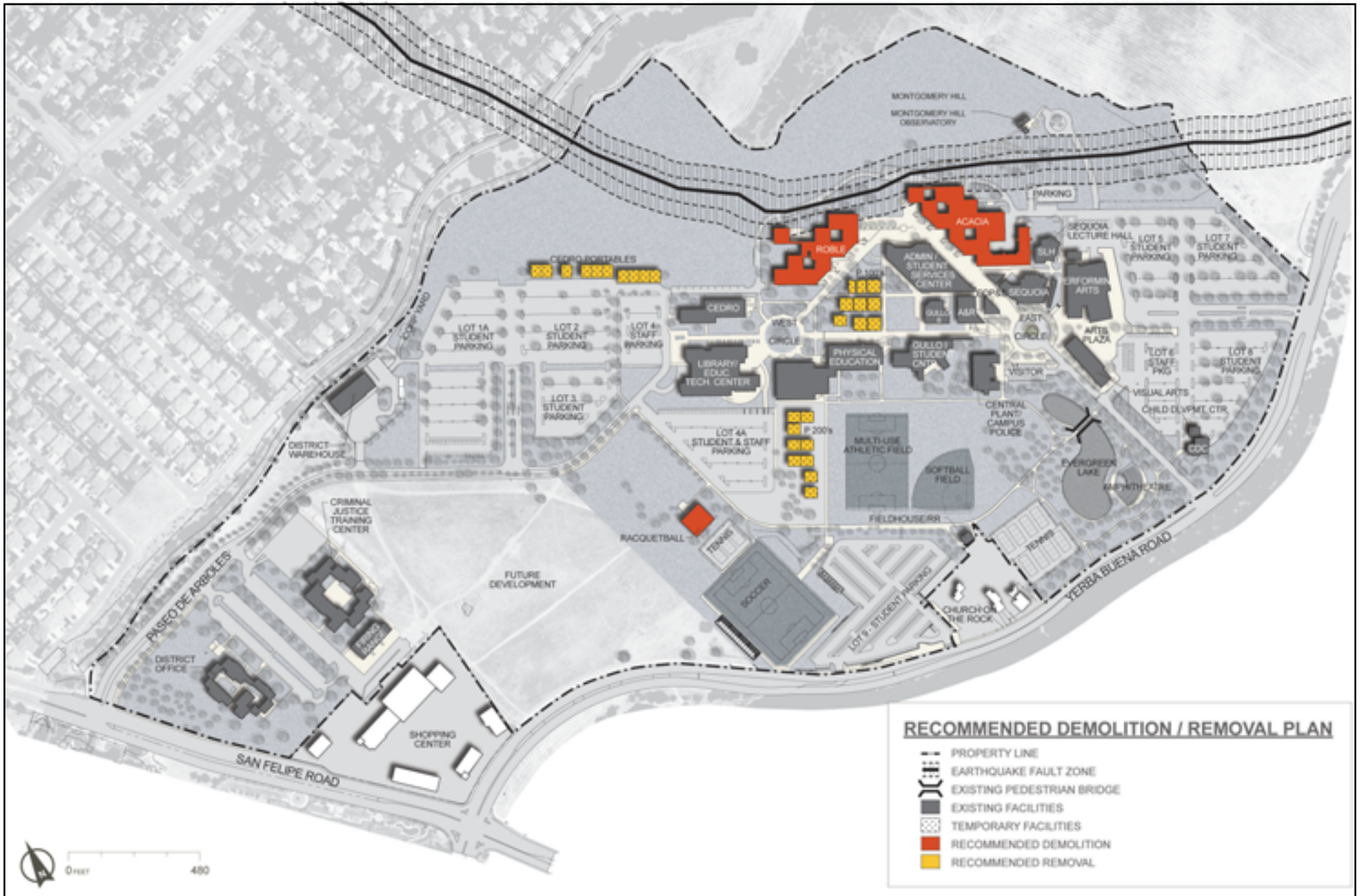

SOURCE: Evergreen Valley College 2025 Facilities Master Plan – November 2011

FIGURE 3

Recommended Demolition/Removal Plan

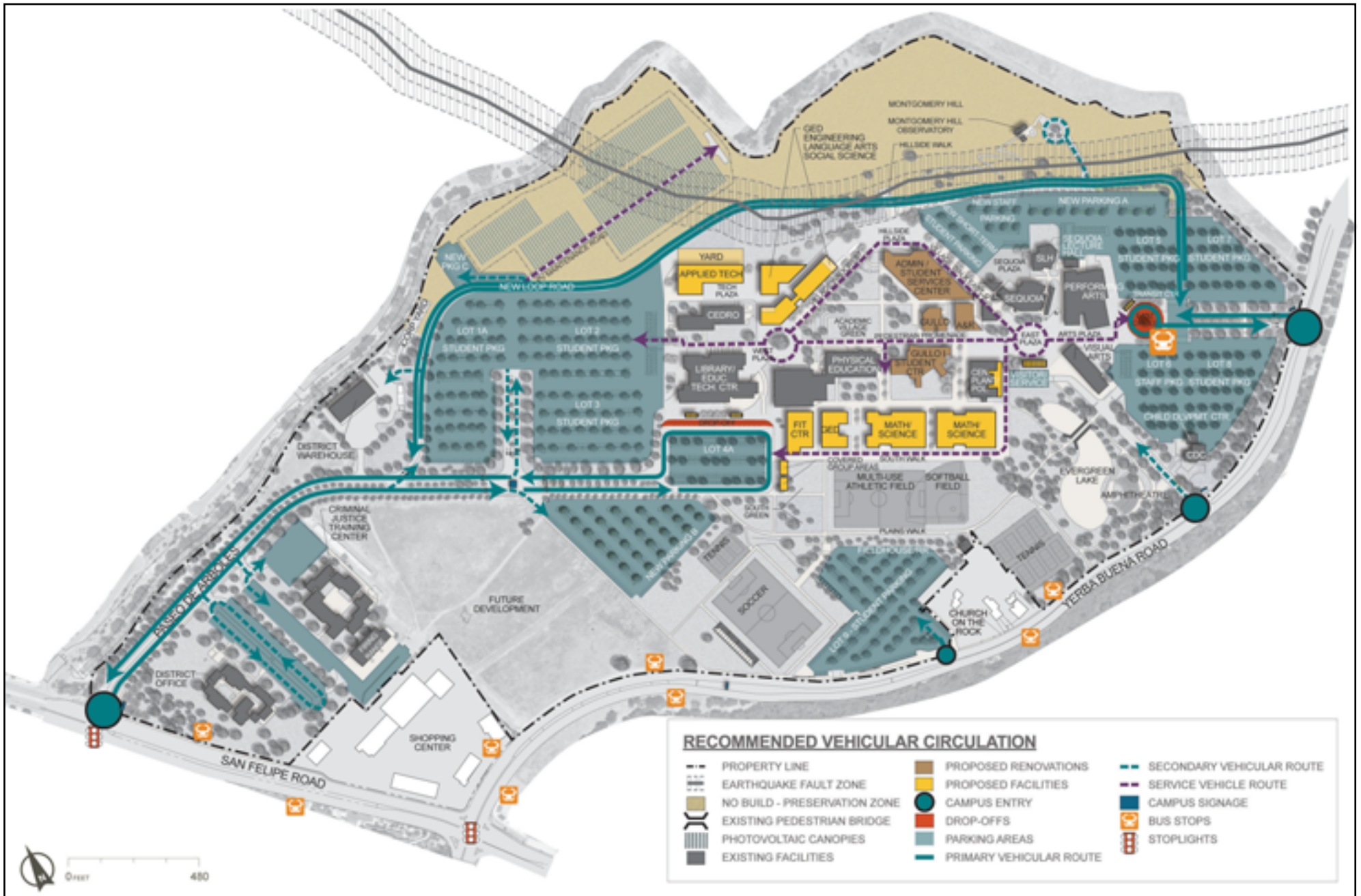

SOURCE: Evergreen Valley College 2025 Facilities Master Plan – November 2011

FIGURE 4

Recommended Vehicular Circulation Plan

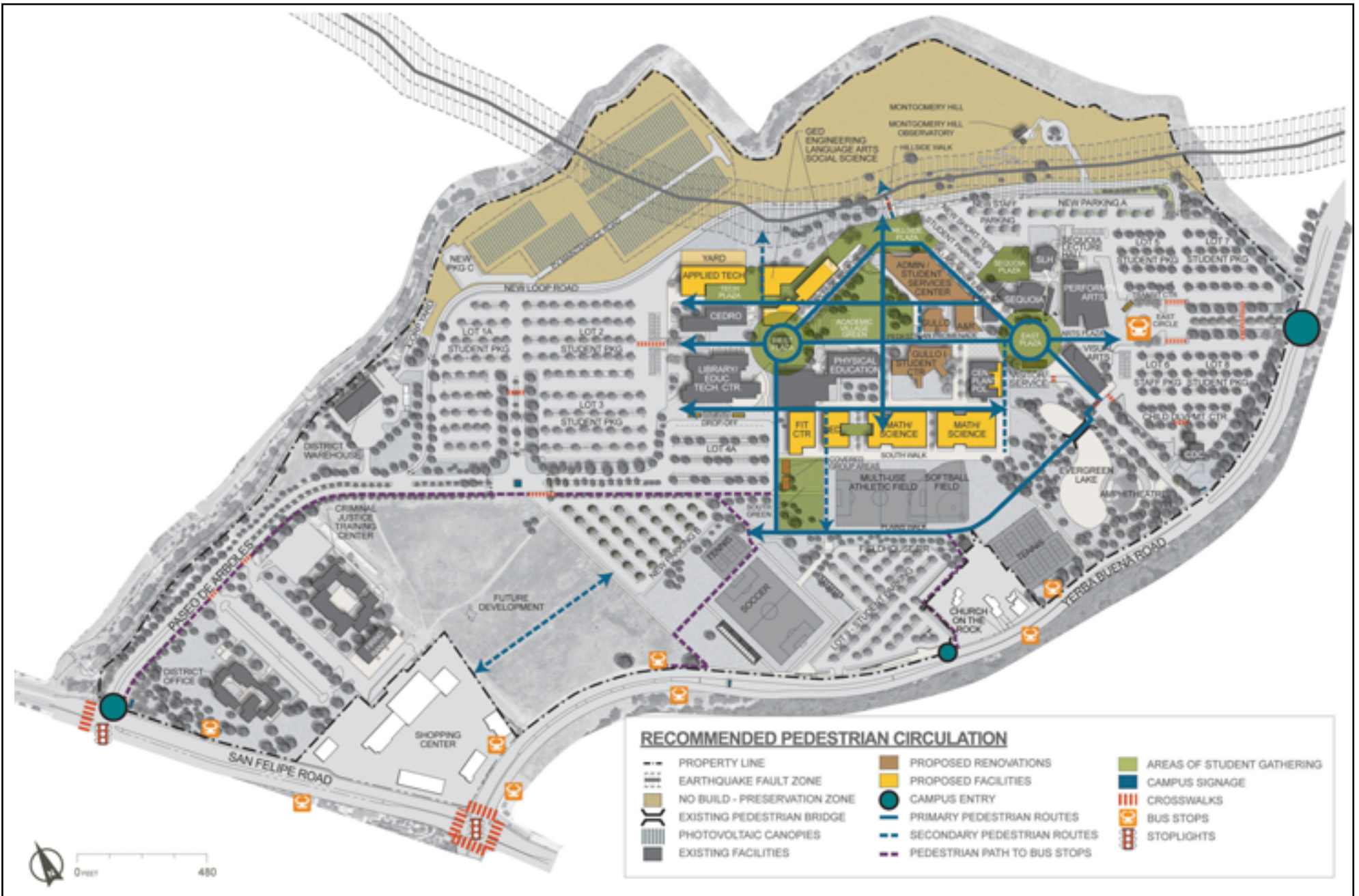

SOURCE: Evergreen Valley College 2025 Facilities Master Plan – November 2011

FIGURE 5

## Recommended Pedestrian Circulation Plan



SOURCE: Evergreen Valley College 2025 Facilities Master Plan – November 2011

FIGURE 6

## Recommended Landscape Improvements





SOURCE: Google Earth – September 2011

FIGURE 7

# Surrounding Land Uses

### III. ENVIRONMENTAL FACTORS POTENTIALLY AFFECTED

The environmental factors checked below could be potentially affected by the implementation of the proposed 2025 FMP and/or by cumulative impacts resulting from implementation of the proposed 2025 FMP in conjunction with other expected developments through 2025. These factors will be evaluated in the EIR.

- Aesthetics
- Air Quality
- Cultural Resources
- Greenhouse Gas Emissions
- Hydrology/Water Quality
- Mineral Resources
- Population and Housing
- Recreation
- Utilities/Service Systems
- Agriculture and Forest Resources
- Biological Resources
- Geology and Soils
- Hazards & Hazardous Materials
- Land Use/Planning
- Noise
- Public Services
- Transportation/Circulation
- Mandatory Findings of Significance

**IV. DETERMINATION:**

On the basis of the initial evaluation that follows:

- I find that the proposed project **WOULD NOT** have a significant effect on the environment, and a **NEGATIVE DECLARATION** will be prepared.

- I find that although the proposed project could have a significant effect on the environment, there will not be a significant effect in this case because revisions in the project have been made that will avoid or reduce any potential significant effects to a less than significant level. A **MITIGATED NEGATIVE DECLARATION** will be prepared.

- I find that the proposed project **MAY** have a significant effect on the environment. An **ENVIRONMENTAL IMPACT REPORT** will be prepared.



\_\_\_\_\_  
Douglas Smith

Vice Chancellor of Administrative Services



\_\_\_\_\_  
Date

## V. EVALUATION OF ENVIRONMENTAL IMPACTS

During the completion of the environmental evaluation, the SJECCD relied on the following categories of impacts, noted as column headings in the IS checklist.

- A) "Potentially Significant Impact" is appropriate if there is substantial evidence that the project's effect may be significant. If there are one or more "Potentially Significant Impacts" for which effective mitigation may not be possible, an EIR will be prepared.
- B) "Less Than Significant With Mitigation Incorporated" applies where the incorporation of project-specific mitigation would reduce an effect from "Potentially Significant Impact" to a "Less Than Significant Impact."
- C) "Less Than Significant Impact" applies where the project would not result in a significant effect (i.e., the project impact would be less than significant without the need to incorporate mitigation).
- D) "No Impact" applies where the project would not result in any impact in the category or the category does not apply. This may be because the impact category does not apply to the proposed project (for instance, the project site is not within a surface fault rupture hazard zone), or because of other project-specific factors.

**Impact Questions and Responses**

<b>Issues</b>	Potentially Significant Impact	Less than Significant with Project Mitigation	Less Than Significant Impact	No Impact
<b>1. AESTHETICS – Would the project:</b>				
a) Have a substantial adverse effect on a scenic vista?	<input type="checkbox"/>	<input type="checkbox"/>	<input type="checkbox"/>	<input checked="" type="checkbox"/>
b) Substantially damage scenic resources, including, but not limited to, trees, rock outcroppings, and historic buildings within a state scenic highway?	<input type="checkbox"/>	<input type="checkbox"/>	<input type="checkbox"/>	<input checked="" type="checkbox"/>
c) Substantially degrade the existing visual character or quality of the site and its surroundings?	<input checked="" type="checkbox"/>	<input type="checkbox"/>	<input type="checkbox"/>	<input type="checkbox"/>
d) Create a new source of substantial light or glare which would adversely affect day or nighttime views in the area?	<input checked="" type="checkbox"/>	<input type="checkbox"/>	<input type="checkbox"/>	<input type="checkbox"/>

**Relevant Elements of the Project and its Setting**

The proposed project consists of the demolition of existing campus buildings and construction of replacement facilities identified in the 2025 FMP to meet future growth projections on campus. The campus is located in a hilly region, but the topography of the campus is relatively flat and the campus is mostly developed. Based on a review of the San José 2020 *General Plan*, there are no scenic vistas that include the campus as a major part of the view (San José 1994).

**Discussion of Potential Project Impacts**

a) A scenic vista is generally defined as an expansive view of highly valued landscape as observable from a publicly accessible vantage point. Although there are views across the campus to the San Felipe Hills, and views from within the campus that are of high visual quality, the existing development on the campus itself does not interfere with visual resources. There are no scenic vistas that include the campus as a major part of the view. The campus is screened from the view of adjacent residents south of Park Estates Way by riparian vegetation to the south of the campus. The campus is partially screened from the view of adjacent residents north of Falls Creek Drive by the existing District Warehouse and riparian vegetation. Views of the north campus parking lot and portions of campus buildings are available from areas along Falls Creek Drive; however, these views are not of high visual quality (SJECCD 2000). Distant views of the campus are available from higher elevations along Yerba Buena Road southwest of the campus; from these viewpoints, campus development appears against the backdrop of surrounding residential development and open space.

The proposed new structures would be sited in undeveloped areas of the campus. However, the proposed facilities would be similar in type and scale to the existing college facilities and would be built within the existing campus boundaries. Furthermore, as noted above, there are no scenic vistas that include the campus as a major part of the view. Therefore, there would not be a substantial change to any

scenic vistas. Based on these factors, the proposed project would have no impact with regard to this criterion.

b) There are no state-designated scenic highways in the vicinity of the campus (CSHP 2011). Therefore, changes on the campus as a result of the 2025 FMP implementation would not affect visual resources associated with any state-designated or local scenic highway. There would be no impact with regard to this criterion.

c) Facilities identified in the 2025 FMP would be similar in type and scale to existing facilities on the campus, and new facilities would be constructed entirely within the campus. However, there is still the potential that implementation of the 2025 FMP could alter the existing visual character and quality of the campus as viewed from the surrounding neighborhoods. In addition, the construction of facilities identified in the 2025 FMP could result in the loss of mature trees, which would further alter the existing visual character of the campus. This represents a potentially significant impact. The effects of the 2025 FMP on the existing visual character or quality of the campus and its surroundings will be analyzed in the EIR.

d) Existing buildings on the campus are a source of light and glare, and cars on the campus may also be a source of glare. Other existing sources of light and glare on the campus include sports facilities and lighting in parking lots and along pathways. New buildings proposed under the 2025 FMP would shift some light and glare sources within the campus, and could increase light and glare in parts of the campus. This represents a potentially significant impact. The effects of light and glare associated with the 2025 FMP implementation on the campus and its surroundings will be analyzed in the EIR.

#### Discussion of Potential Cumulative Impacts

The proposed project combined with other current projects and probable future projects and projected regional growth could result in significant cumulative impacts with regard to visual character and light and glare. These issues will be addressed in the EIR.

<b>Issues</b>	Potentially Significant Impact	Less Than Significant with Mitigation Incorporated	Less Than Significant Impact	No Impact
---------------	--------------------------------------	--	------------------------------------	--------------

**2. AGRICULTURE AND FORESTRY RESOURCES –**

Would the project:

a) Convert Prime Farmland, Unique Farmland, or Farmland of Statewide Importance (Farmland), as shown on the maps prepared pursuant to the Farmland Mapping and Monitoring Program of the California Resources Agency, to non-agricultural use?	<input type="checkbox"/>	<input type="checkbox"/>	<input type="checkbox"/>	<input checked="" type="checkbox"/>
b) Conflict with existing zoning for agricultural use, or a Williamson Act contract?	<input type="checkbox"/>	<input type="checkbox"/>	<input type="checkbox"/>	<input checked="" type="checkbox"/>
c) Conflict with existing zoning for, or cause rezoning of, forest land (as defined in Public Resources Code section 12220(g)), timberland (as defined in Public Resources Code Section 4526), or Timberland zoned Timberland Production (as defined by Government Code section 51104(g))?	<input type="checkbox"/>	<input type="checkbox"/>	<input type="checkbox"/>	<input checked="" type="checkbox"/>
d) Result in the loss of forest land or conversion of forest land to non-forest use?	<input type="checkbox"/>	<input type="checkbox"/>	<input type="checkbox"/>	<input checked="" type="checkbox"/>
e) Involve other changes in the existing environment, which, due to their location or nature, could result in conversion of Farmland, to non-agricultural use or conversion of forest land to non-forest use?	<input type="checkbox"/>	<input type="checkbox"/>	<input type="checkbox"/>	<input checked="" type="checkbox"/>

Relevant Elements of the Project and its Setting

The proposed project consists of the demolition of existing campus buildings and construction of replacement facilities identified in the 2025 FMP to meet future growth projections on campus. The campus is designated as Urban and Built-Up Land and Other Land on maps prepared by the California State Department of Conservation pursuant to the Farmland Mapping and Monitoring Program (FMMP) (FMMP 2011).

Discussion of Potential Project Impacts

a) The entire campus is developed and located in a developed area of the City of San José. The campus is not used for agriculture, and is not designated as Farmland on maps prepared by the California State Department of Conservation pursuant to the FMMP. There would be no impact with regard to this criterion.

b-c) Although the campus is not subject to City zoning, the campus is zoned for urban use by the City of San José. No portion of the campus is zoned for agricultural use, forest land, or timberland. In addition,

there is no Williamson Act contract applicable to the campus. Therefore, future development on the campus would not conflict with existing zoning for agricultural or forest land or timberland use or with a Williamson Act contract. There would be no impact with regard to this criterion.

d) The campus and surrounding area does not include any forest land or timberland. There would be no impact with regard to this criterion.

e) No Farmland or other agricultural land is present in the vicinity of the campus. Therefore, implementation of the 2025 FMP would not involve any changes that could indirectly cause conversion of Farmland to non-agricultural use. There would be no impact with regard to this criterion.

#### Discussion of Potential Cumulative Impacts

The City of San José is urban in nature, and is not designated as Farmland on maps prepared pursuant to the FMMP. As a result, anticipated future development in San José, including the future development on the campus under the 2025 FMP, would not result in the loss of Farmland. In addition, land in the City is zoned for urban uses. Therefore, anticipated future development in San José would not displace land zoned for agricultural use or forest land or timberland, and would not conflict with land under a Williamson Act contact. The impact of cumulative development on agricultural and forest resources would be less than significant.



<b>Issues</b>	Potentially Significant Impact	Less than Significant with Project Mitigation	Less Than Significant Impact	No Impact
---------------	--------------------------------	---	------------------------------	-----------

**3. AIR QUALITY** – Where available, the significance criteria established by the applicable air quality management or air pollution control district may be relied upon to make the following determinations. Would the project:

a) Conflict with or obstruct implementation of the applicable air quality plan?	■	□	□	□
b) Violate any air quality standard or contribute substantially to an existing or projected air quality violation?	■	□	□	□
c) Result in a cumulatively considerable net increase of any criteria pollutant for which the project region is non-attainment under an applicable federal or state ambient air quality standard (including releasing emissions which exceed quantitative thresholds for ozone precursors)?	■	□	□	□
d) Expose sensitive receptors to substantial pollutant concentrations?	■	□	□	□
e) Create objectionable odors affecting a substantial number of people?	□	□	■	□

Relevant Elements of the Project and its Setting

The proposed project consists of the demolition of existing campus buildings and construction of replacement facilities identified in the 2025 FMP to meet future growth projections on the campus. The nearest sensitive receptors to the campus include single-family residential uses to the north, south, and west. Other sensitive receptors in the vicinity of the campus include Evergreen Park and Church on the Rock - Baptist to the south; Montgomery Hill Park to the east; and an assisted-living facility to the west.

Discussion of Potential Project Impacts

a-c) The campus is located in the San Francisco Bay Area Air Basin, which is currently designated a non-attainment area for PM10 (particulate matter 10 microns or less in diameter), PM2.5 (particulate matter 2.5 microns or less in diameter), and ozone. Construction and operation of facilities identified in the 2025 FMP would be likely to add incrementally to regional ambient air pollutant emissions including short- and long-term emissions of criteria air pollutants from mobile and stationary sources. This represents a potentially significant impact. The EIR will estimate the total emissions from construction and operation of future buildings identified in the 2025 FMP and evaluate whether the emissions would exceed the Bay

Area Air Quality Monitoring District (BAAQMD) recommended thresholds for evaluating impacts from criteria pollutant emissions.

d) Construction of facilities identified in the 2025 FMP would result in on-site emissions of diesel particulate matter, which the California Air Resources Board has identified as a toxic air contaminant. In addition, operation of facilities identified in the 2025 FMP could impact nearby sensitive receptors by creating the potential for localized CO hotspots. This represents a potentially significant impact. The EIR will evaluate concentrations of CO, toxic air contaminants, and other pollutants associated with the 2025 FMP to determine whether they would result in a significant effect on sensitive receptors.

e) Construction of facilities identified in the 2025 FMP would require the use of diesel-fueled equipment and architectural coatings, both of which have an associated odor. However, these odors would be short-term and temporary and would not be pervasive enough to affect a substantial number of people or to be objectionable. Routine operation of facilities identified in the 2025 FMP would not involve activities that typically produce odors such as wastewater treatment, manufacturing, agriculture, etc. Occasional use of maintenance products on the campus could produce odors but they would be temporary and limited in area. Consequently, odors associated with short-term construction and long-term operation of facilities under the 2025 FMP would not cause or be affected by odors, and the impact would be less than significant.

#### Discussion of Potential Cumulative Impacts

The construction and operation of facilities identified in the 2025 FMP combined with other current projects and probable future projects and projected regional growth could result in significant cumulative impacts with regard to air quality. This issue will be addressed in the EIR.

<b>Issues</b>	Potentially Significant Impact	Less than Significant with Project Mitigation	Less Than Significant Impact	No Impact
---------------	--------------------------------	---	------------------------------	-----------

**4. BIOLOGICAL RESOURCES – Would the project:**

a) Have a substantial adverse effect, either directly or through habitat modifications, on any species identified as a candidate, sensitive, or special status species in local or regional plans, policies, or regulations, or by the California Department of Fish and Game or U.S. Fish and Wildlife Service?

b) Have a substantial adverse effect on any riparian habitat or other sensitive natural community identified in local or regional plans, policies, regulations or by the California Department of Fish and Game or US Fish and Wildlife Service?

c) Have a substantial adverse effect on federally protected wetlands as defined by Section 404 of the Clean Water Act (including, but not limited to, marsh, vernal pool, coastal, etc.) through direct removal, filling, hydrological interruption, or other means?

d) Interfere substantially with the movement of any native resident or migratory fish or wildlife species or with established native resident or migratory wildlife corridors, or impede the use of native wildlife nursery sites?

e) Conflict with any applicable policies protecting biological resources, such as a tree preservation policy or ordinance?

f) Conflict with the provisions of an adopted Habitat Conservation Plan, Natural Community Conservation Plan, or other applicable local, regional, or state habitat conservation plan?

Relevant Elements of the Project and its Setting

The proposed project consists of the demolition of existing campus buildings and construction of replacement facilities identified in the 2025 FMP to meet future growth projections on the campus. The campus is located within a suburban setting within the Evergreen Valley. A majority of the campus is developed, except for undeveloped areas in the northern and southern portions of campus (SJECCD 2000). The undeveloped portions of the campus consist mainly of disturbed grasslands.

### Discussion of Potential Project Impacts

a) The most recent versions of the California Natural Diversity Database (CNDDDB) and California Native Plant Society (CNPS) databases were reviewed for the vicinity of the campus. According to CNDDDB and CNPS query results, several special-status plant and wildlife species have been documented in the project area (i.e., within 3 miles of the campus). Undeveloped grasslands may provide habitat for special-status species and development under the 2025 FMP could disturb these species. This represents a potentially significant impact. The EIR will analyze potential impacts to special-status plant and wildlife species and associated habitat potentially occurring on or near the campus.

b) The campus is generally developed, and is not identified in any adopted plan as having sensitive natural communities. However, there are undeveloped areas in the northern and southern portions of the campus, and two creeks, Thompson Creek and Yerba Buena Creek, are located near the western and southern campus boundaries, respectively. In addition, there is an unnamed drainage north of the campus (SJECCD 2000). As a result, development under the 2025 FMP could impact the riparian habitats present along these drainages. This represents a potentially significant impact. The EIR will identify and analyze potential impacts regarding sensitive and/or riparian habitats within or near the campus.

c) Evergreen Lake is located within the southeast portion of the campus, and further analysis is required to determine if this lake may be considered a federally protected wetland or waters of the United States. Construction of facilities identified in the 2025 FMP in the vicinity of Evergreen Lake could affect this feature. Additionally, further analysis is required to determine if wetland habitats occur within the undeveloped grassland portions of the campus in the areas where new facilities would be built under the 2025 FMP. Therefore, impacts to jurisdictional resources are considered a potentially significant impact. The EIR will identify and analyze impacts regarding impacts to jurisdictional resources.

d) Undeveloped portions of the campus contain disturbed grassland that provides biological resource values, including habitat for wildlife. In addition, two creeks, Thompson Creek and Yerba Buena Creek, are located near the western and southern boundaries of the campus. Therefore, the campus may provide wildlife movement corridors or nursery sites, and the implementation of the 2025 FMP could have impacts on such resources). In addition, mature trees on the campus could provide nesting habit to migratory bird species that are protected under state and federal laws. Construction activity associated with development under the 2025 FMP could result in the removal of trees on the campus. If removal of trees occurred during breeding season, this action could result in the disruption of nesting activities. This represents a potentially significant impact. The EIR will identify and evaluate potential impacts related to wildlife movement corridors or nesting migratory birds.

e) Construction of facilities identified in the 2025 FMP may require the removal of some trees, regardless of health, to facilitate development or to mitigate potentially hazardous circumstances related to their proximity to existing facilities. The City of San José has a tree ordinance that requires a permit for removal of any trees on private property that have a trunk circumference of 56 inches or more, measured 2 feet above grade. As a state entity, the SJECCD is exempted by the state constitution from compliance with local land use regulations and ordinances. There would be no impact with respect to this criterion.

f) No adopted habitat conservation plan or natural community conservation plan applies to the campus. There would be no impact with respect to this criterion. However, a habitat conservation plan/natural community conservation plan is currently being prepared for the Santa Clara Valley and the campus is located within the boundaries of the plan.

Discussion of Potential Cumulative Impacts

The construction and operation of facilities identified in the 2025 FMP combined with other current projects and probable future projects and projected regional growth could result in significant cumulative impacts on biological resources. This issue will be addressed in the EIR.

<b>Issues</b>	Potentially Significant Impact	Less than Significant with Project Mitigation	Less Than Significant Impact	No Impact
---------------	--------------------------------	---	------------------------------	-----------

**5. CULTURAL RESOURCES – Would the project:**

a) Cause a substantial adverse change in the significance of a historical resource as defined in Section 15064.5?	<input type="checkbox"/>	<input type="checkbox"/>	<input type="checkbox"/>	<input checked="" type="checkbox"/>
b) Cause a substantial adverse change in the significance of an archaeological resource pursuant to Section 15064.5?	<input type="checkbox"/>	<input checked="" type="checkbox"/>	<input type="checkbox"/>	<input type="checkbox"/>
c) Directly or indirectly destroy a unique paleontological resource or site or unique geologic feature?	<input type="checkbox"/>	<input checked="" type="checkbox"/>	<input type="checkbox"/>	<input type="checkbox"/>
d) Disturb any human remains, including those interred outside of formal cemeteries?	<input type="checkbox"/>	<input checked="" type="checkbox"/>	<input type="checkbox"/>	<input type="checkbox"/>

Relevant Elements of the Project and its Setting

The proposed project consists of the demolition of existing campus buildings and construction of replacement facilities identified in the 2025 FMP to meet future growth projections on the campus. The buildings on the campus date from the 1970s through the 2000s. According to the Northwest Information Center (NWIC), there is a high potential for identifying unrecorded Native American resources and historic-period archaeological resources on or near the EVC campus (NWIC 2011). Construction of individual buildings and facilities would include site grading and excavation, and thus could uncover unknown resources.

Discussion of Potential Project Impacts

a) Under CEQA, “historic resources” means historic buildings or features or historic or prehistoric archaeological deposits that qualify for inclusion on the California Register of Historic Resources based on their historical or prehistoric significance. Several buildings on the campus are identified in the 2025 FMP for demolition. These include the Cluster Acacia, Cluster Roble, Racquetball courts, and all portable buildings. The Cluster Acacia, Cluster Roble, and Racquetball courts were built in the 1970s. The portable buildings were constructed in the 2000s. Due to their age, none of these structures appears to be potentially eligible for inclusion in the National Register of Historic Places or the California Register of Historic Resources. Thus, the implementation of the 2025 FMP will have no impact on significant historic resources.

b) The NWIC was contacted to conduct an archaeological records search for the campus and surrounding area. The NWIC indicated that there is a high potential of identifying unrecorded Native American resources on or near the EVC campus because the campus is located at a valley/foothill interface and is bounded by Yerba Buena creek to the south and because multiple Native American archaeological resources, including burials, have been found in the vicinity of the campus. In addition, there is a high potential of identifying unrecorded historic-period archaeological resources on or near the campus as a

review of older maps (1942 San José 15-minute topographic quadrangle and 1876 Historical Atlas of Santa Clara County) depict buildings within the project area (NWIC 2011). Any inadvertent damage to significant Native American and historic-period archaeological resources represents a potentially significant impact. The EIR will analyze the potential impacts related to Native American and historic-period archaeological resources on campus.

c) While the majority of campus is situated on alluvial fan sediments, sandstone and shale bedrock has been encountered on campus. The presence of bedrock suggests that the presence of unique paleontological resources on campus is possible (SJECCD 2000). As a result, there is a possibility that paleontological resources may exist at deep levels, and disturbance of such resources would result in a potentially significant impact. However, implementation of **Mitigation Measure CUL-3** would reduce impacts to a less than significant level.

**Mitigation Measure CUL-3:** If known, suspected, or potential vertebrate fossil materials are discovered during construction, work will stop within a 75-foot radius of the find until a qualified professional paleontologist (as defined by the Society of Vertebrate Paleontology or consistent with Caltrans standards for a Supervising Paleontologist) can assess the nature and importance of the find and recommend appropriate treatment, if any. Based on the paleontologist's professional judgment, treatment may include preparation and recovery of fossil materials so that they can be housed in an appropriate museum or university collection, and may also include preparation of a report for publication describing the finds. The campus will be responsible for ensuring that the paleontologist's recommendations regarding treatment and reporting are implemented.

d) See the responses to **Items 5(a)** and **(b)**, above. Multiple Native American archaeological resources, including burials, have been found in the vicinity of the campus. It is therefore possible that human remains of Native American origin could be present on the campus. Any disturbance of human remains would represent a potentially significant impact. However, with implementation of **Mitigation Measure CUL-4**, which outlines procedures to be followed in the event that previously unknown human remains are discovered, any impacts would be reduced to a less than significant level.

**Mitigation Measure CUL-4:** In the event of a discovery of human bone, potential human bone, or a known or potential human burial, all ground-disturbing work in the vicinity of the find will halt immediately and the area of the find will be protected until a qualified archaeologist determines whether the bone is human. If the qualified archaeologist determines the bone is human, the Campus will notify the County Coroner of the find. Consistent with California Health and Safety Code Section 7050.5(b), which prohibits disturbance of human remains uncovered by excavation until the Coroner has made a finding relative to the requirements of Public Resources Code Section 5097, the Campus will ensure that the remains and vicinity of the find are protected against further disturbance.

If it is determined that the find is of Native American origin, the Campus will comply with the provisions of Public Resources Code Section 5097.98 regarding identification and involvement of the Most Likely Descendant (MLD).

If the human remains cannot be protected in place following the Coroner's determination, the Campus shall ensure that the qualified archaeologist and the MLD are provided the opportunity to confer on repatriation and/or archaeological treatment of human remains, and

that any appropriate studies, as identified through this consultation, are carried out prior to reinterment. The Campus shall provide results of all such studies to the Native American community, and shall provide an opportunity for Native American involvement in any interpretative reporting. As stipulated by the provisions of the California Native American Graves Protection and Repatriation Act, the Campus shall ensure that human remains and associated artifacts recovered from campus projects on state lands are repatriated to the appropriate local tribal group if requested.

#### Discussion of Potential Cumulative Impacts

Anticipated future development in some portions of San José has the potential to adversely affect cultural resources in the City. However, with mitigation, future development on the campus under the 2025 FMP would have no project-level impacts on cultural resources. Therefore, implementation of the 2025 FMP would not make a cumulatively considerable contribution to a cumulative impact on cultural resources that could result from other development in the City.



<b>Issues</b>	Potentially Significant Impact	Less than Significant with Project Mitigation	Less Than Significant Impact	No Impact
---------------	--------------------------------	---	------------------------------	-----------

**6. GEOLOGY AND SOILS – Would the project:**

a) Expose people or structures to potential substantial adverse effects, including the risk of loss, injury, or death involving:

i) Rupture of a known earthquake fault, as delineated on the most recent Alquist-Priolo Earthquake Fault Zoning Map issued by the State Geologist for the area or based on other substantial evidence of a known fault? Refer to Division of Mines and Geology Special Publication 42.	<input type="checkbox"/>	<input type="checkbox"/>	<input type="checkbox"/>	<input checked="" type="checkbox"/>
ii) Strong seismic ground shaking?	<input checked="" type="checkbox"/>	<input type="checkbox"/>	<input type="checkbox"/>	<input type="checkbox"/>
iii) Seismic-related ground failure, including liquefaction?	<input type="checkbox"/>	<input type="checkbox"/>	<input type="checkbox"/>	<input checked="" type="checkbox"/>
iv) Landslides?	<input checked="" type="checkbox"/>	<input type="checkbox"/>	<input type="checkbox"/>	<input type="checkbox"/>
b) Result in substantial soil erosion or the loss of topsoil?	<input type="checkbox"/>	<input type="checkbox"/>	<input checked="" type="checkbox"/>	<input type="checkbox"/>
c) Be located on a geologic unit or soil that is unstable, or that would become unstable as a result of the project, and potentially result in on- or off-site landslide, lateral spreading, subsidence, liquefaction or collapse?	<input checked="" type="checkbox"/>	<input type="checkbox"/>	<input type="checkbox"/>	<input type="checkbox"/>
d) Be located on expansive soil, as defined in Table 18-1-B of the Uniform Building Code (1994), creating substantial risks to life or property?	<input checked="" type="checkbox"/>	<input type="checkbox"/>	<input type="checkbox"/>	<input type="checkbox"/>
e) Have soils incapable of adequately supporting the use of septic tanks or alternative waste water disposal systems where sewers are not available for the disposal of waste water?	<input type="checkbox"/>	<input type="checkbox"/>	<input type="checkbox"/>	<input checked="" type="checkbox"/>

Relevant Elements of the Project and its Setting

The proposed project consists of the demolition of existing campus buildings and construction of replacement facilities identified in the 2025 FMP to meet future growth projections on the campus. The topography of the campus is relatively flat but is surrounded by hillside areas. The eastern portion of campus is traversed by the Evergreen fault.

### Discussion of Potential Project Impacts

a)(i) An Alquist-Priolo Earthquake Fault Zone<sup>1</sup> associated with the Evergreen fault passes through the eastern portion of the campus (CGS 2011), and this fault is considered active (URS 2011). However, no new development associated with the 2025 FMP would occur within the earthquake fault zone, and the Roble and Acacia cluster buildings that currently lie partly within this zone would be demolished. As a result, future development on the campus would not expose structures and people to hazards associated with the rupture of a known earthquake fault. There would be no impact with regard to this criterion.

a)(ii) The campus could be subject to strong ground shaking in the event of an earthquake originating along active portions of the Evergreen fault or numerous other faults listed as active or potentially active in the Bay Area. Development of new buildings and facilities under the 2025 FMP thus could pose a risk to public safety and property by exposing people, property, or infrastructure to potentially adverse effects, including strong seismic ground shaking. This impact is considered potentially significant. The EIR will identify and characterize potential impacts related to strong seismic ground shaking.

a)(iii) The campus is not located in a liquefaction hazard zone designated by the State of California pursuant to the Seismic Hazards Mapping Act of 1990 (CGS 2001). As a result, future development on the campus would not expose structures and people to hazards associated with seismic-related ground failure, including liquefaction. There would be no impact with regard to this criterion.

a)(iv) The hills in the northern portion of campus are considered to be susceptible to earthquake-induced landslides by the State of California pursuant to the Seismic Hazards Mapping Act of 1990 (CGS 2001). Although no development is planned in the more steeply sloped hillside areas of campus, future development adjacent to these slopes could expose structures and people to hazards associated with landslides. This impact is considered potentially significant. The EIR will identify and characterize potential impacts related to landslides originating from the surrounding hillside areas.

b) Construction of facilities identified in the 2025 FMP would require activities such as vegetation removal and grading that would expose soil to erosion. For projects that would disturb 1 acre or more, coverage under the state National Pollutant Discharge Elimination System (NPDES) General Permit for Discharges of Storm Water Associated with Construction Activity would be required prior to construction and the construction contractor would be required to file a notice of intent (NOI) with the State Water Resources Control Board and develop and implement a site-specific Storm Water Pollution Prevention Plan (SWPPP) that specifies Best Management Practices (BMPs) to control on-site erosion and off-site sedimentation, and to keep construction pollutants from coming into contact with storm water. The campus would have oversight responsibility and would have the authority to shut down construction in the event the SWPPP is improperly implemented. For projects that would disturb less than 1 acre, the campus would develop an erosion control plan which would include sediment and erosion controls to limit on-site erosion and off-site sedimentation, and to keep construction pollutants from coming into contact with storm water. With these measures in place, impacts related to accelerated erosion and sedimentation are expected to be less than significant.

c) Weak soil layers and lenses occur at random locations and depths beneath the campus (SJECCD 2001). Therefore, future development on the campus could be located on a geologic unit or soil that is unstable, or that would become unstable as a result of development. Issues related to seismically induced and non-

---

<sup>1</sup> Prior to 1994, Earthquake Fault Zones were called Special Studies Zones.

seismic landslide hazards are discussed in response to **Item (a)(iv)**, above, and as noted there, will be addressed in the EIR. Issues related to liquefaction and related hazards are discussed in response to **Item (a)(iii)**, above, and as noted the impacts would be less than significant. Issues related to soil properties are discussed in response to **Item (d)** below, and the impact would be less than significant. Construction of facilities identified in the 2025 FMP may require the creation of cut or fill slopes, which could be unstable if they are improperly designed or constructed. However, development would be designed and constructed in accordance with the current CBC, which includes provisions that specifically address good grading practices and cut and fill slope stability. Impacts related to unstable cut or fill slopes are therefore expected to be less than significant.

d) The expansive potential for soils on the eastern portion of campus could cause damage to buildings, building foundations, roads, and other structures (SJECCD 2001). The properties of native materials that underlie individual development sites on the campus at depth would be evaluated during the development of the site-specific geotechnical investigations that the campus will prepare for the project design of each new facility identified by the 2025 FMP. As discussed above, all facilities identified in the 2025 FMP will adhere to the current CBC, which includes detailed provisions to ensure that the design of new facilities is appropriate to site soil conditions, including requirements to address expansive and otherwise problematic soils. With adherence to the CBC, impacts related to site soil conditions—including but not limited to expansive soils, if any are present—would be less than significant.

e) Future development on the campus under the 2025 FMP would not involve the installation of septic tanks or alternative wastewater disposal systems. There would be no impact with regard to this criterion.

#### Discussion of Potential Cumulative Impacts

The construction and operation of facilities identified in the 2025 FMP combined with other current projects and probable future projects and projected regional growth could result in significant cumulative impacts with regard to geology and soils. This issue will be addressed in the EIR.

Issues	Potentially Significant Impact	Less than Significant with Project Mitigation	Less Than Significant Impact	No Impact
<b>7. GREENHOUSE GAS EMISSIONS –</b> Would the project:				
a) Generate greenhouse gas emissions, either directly or indirectly, that may have a significant impact on the environment?	■	□	□	□
b) Conflict with any applicable plan, policy or regulation of an agency adopted for the purpose of reducing the emissions of greenhouse gases?	■	□	□	□

Relevant Elements of the Project and its Setting

The proposed project consists of the demolition of existing campus buildings and construction of replacement facilities identified in the 2025 FMP to meet future growth projections on the campus.

Discussion of Potential Project Impacts

a-b) Construction and operation of facilities identified in the 2025 FMP to meet future growth projections on the campus would generate greenhouse gas (GHG) emissions. This represents a potentially significant impact. The EIR will estimate the direct and indirect GHG emissions from the operation of facilities identified in the 2025 FMP and discuss whether the emissions would exceed the BAAQMD’s recommended thresholds for evaluation of GHG impacts. The EIR will also estimate and report GHG emissions that would be generated during construction of facilities identified in the 2025 FMP.

Discussion of Potential Cumulative Impacts

The contribution of the 2025 FMP to the global cumulative impact will be addressed in the EIR.

Issues	Potentially Significant Impact	Less than Significant with Project Mitigation	Less Than Significant Impact	No Impact
<b>8. HAZARDS AND HAZARDOUS MATERIALS</b>				
– Would the project:				
a) Create a significant hazard to the public or the environment through the routine transport, use, or disposal of hazardous materials?	<input type="checkbox"/>	<input type="checkbox"/>	<input checked="" type="checkbox"/>	<input type="checkbox"/>
b) Create a significant hazard to the public or the environment through reasonably foreseeable upset and accident conditions involving the release of hazardous materials into the environment?	<input type="checkbox"/>	<input type="checkbox"/>	<input checked="" type="checkbox"/>	<input type="checkbox"/>
c) Emit hazardous emissions or handle hazardous or acutely hazardous materials, substances, or waste within one-quarter mile of an existing or proposed school?	<input type="checkbox"/>	<input type="checkbox"/>	<input type="checkbox"/>	<input checked="" type="checkbox"/>
d) Be located on a site which is included on a list of hazardous materials sites compiled pursuant to Government Code Section 65962.5 and, as a result, would it create a significant hazard to the public or the environment?	<input type="checkbox"/>	<input checked="" type="checkbox"/>	<input type="checkbox"/>	<input type="checkbox"/>
e) For a project located within an airport land use plan or, where such a plan has not been adopted, within 2 miles of a public airport or public use airport, would the project result in a safety hazard for people residing or working in the project area?	<input type="checkbox"/>	<input type="checkbox"/>	<input type="checkbox"/>	<input checked="" type="checkbox"/>
f) For a project within the vicinity of a private airstrip, would the project result in a safety hazard for people residing or working in the project area?	<input type="checkbox"/>	<input type="checkbox"/>	<input type="checkbox"/>	<input checked="" type="checkbox"/>
g) Impair implementation of or physically interfere with an adopted emergency response plan or emergency evacuation plan?	<input type="checkbox"/>	<input type="checkbox"/>	<input type="checkbox"/>	<input checked="" type="checkbox"/>
h) Expose people or structures to a significant risk of loss, injury or death involving wildland fires, including where wildlands are adjacent to urbanized areas or where residences are intermixed with wildlands?	<input type="checkbox"/>	<input type="checkbox"/>	<input type="checkbox"/>	<input checked="" type="checkbox"/>

### Relevant Elements of the Project and its Setting

The proposed project consists of the demolition of existing campus buildings and construction of replacement facilities identified in the 2025 FMP to meet future growth projections on the campus. The campus contains several older buildings that are identified for demolition in the 2025 FMP. The closest schools are Matsumoto Elementary School and Chaboya Middle School, both of which are located approximately 0.5 mile to the north of the campus, and Laurelwood Elementary School, which is located about 0.5 mile to the west of the campus. The nearest airport is Reid-Hillview Airport, located approximately 4 miles to the northwest of the campus.

### Discussion of Potential Project Impacts

a) Although the construction of facilities identified in the 2025 FMP would use small quantities of hazardous materials on each construction site, compliance with local, state, and federal regulations would minimize risks associated with the routine transport, use, or disposal of hazardous materials during construction. Any hazardous materials utilized during the operation of facilities identified in the 2025 FMP would be limited to those typically used in academic support and standard maintenance activities (e.g., laboratory chemicals, photoprocessing chemicals, solvents, fuels, oils, paints, cleaning agents or pesticides). The use of all hazardous materials during operation would be required to comply with stringent local, state, and federal regulations on hazardous materials use. Given the types and small quantities of hazardous materials that would be used, as well as stringent regulations, the impacts related to the routine transport, use, and disposal of hazardous materials would be less than significant.

b) See response to **Item (a)** above. Based on their age, buildings to be demolished as part of the 2025 FMP could contain asbestos, lead, and Polychlorinated Biphenyls (PCBs). State law requires that contractors and workers be notified of the presence of asbestos in buildings constructed before 1979. The California Department of Public Health requires the certification of employees and supervisors performing lead-related construction activities in residential and public buildings. Standard specifications included in all campus construction contracts specify that contractors who disturb or potentially disturb asbestos or lead must comply with all federal, state, and local rules and regulations regarding these materials. Contractors are also required to stop work and inform the Campus if they encounter material believed to be asbestos, PCBs, lead, or other hazardous materials. Compliance with federal, state, and local regulations and campus procedures would minimize possible exposure to campus employees and students. Therefore, this impact would be less than significant.

c) See the responses to **Items 8(a)** and **8(b)** above. The campus is not located within 0.25 mile of a school. There would be no impact with respect to this criterion.

d) The EVC campus is not included on a list of hazardous materials sites subject to corrective action compiled pursuant to Government Code Section 65962.5 (Cortese List). However, as shown in an EDR report that was prepared for the campus, the campus is included on a number of federal, state, and local databases. The inclusion of the campus in these databases stems from hazardous waste related to academic uses and the presence of under and above ground fuel storage tanks on the campus. The generation of hazardous waste at the EVC campus is related to academic and facilities maintenance uses and may include laboratory chemicals, photoprocessing chemicals, solvents, fuels, oils, paints, cleaning agents or pesticides that are currently used in laboratory research, building and grounds maintenance, vehicle maintenance, and fine arts. In addition, hazard materials associated with electrical transmission are also located on campus.

Based on the EDR report, there is currently no known contamination on the project site. The EDR report indicated that several sites with known or potential contamination, hazardous materials use, hazardous waste generation, or other hazardous-materials-related conditions are within 1 mile of the campus (EDR 2011). Known or potentially contaminated sites near the campus include the church property south of the campus on Yerba Buena Road and the shopping center located at the corner of San Felipe Road and Yerba Buena Road. The sources of contamination on these sites include miscellaneous chemicals associated with cellular equipment on the church property, miscellaneous chemicals, and photochemical waste associated with retail uses in the shopping center, and auto wrecking facilities located in the shopping center. Other potential sources of contamination in the vicinity of the project site include hydrocarbons from leaking underground storage tanks, chemical use and waste, and the presence of chemicals in the soil due to past agricultural use in the area (EDR 2011). Because of the site status and orientation relative to groundwater flow direction for the identified sites, it is unlikely that groundwater contamination from these sites may have migrated to the campus (EDR 2011). However, given the uncertainty of contamination on the project site from sources off site, this assessment conservatively assumes that contamination could be present and, if encountered during construction, could result in the exposure of the public or construction workers to hazardous materials. This is considered a potentially significant impact. However, with the implementation of **Mitigation Measure HAZ-1**, which requires an assessment and cleanup of potential contamination that may be encountered during construction, this impact would be reduced to a less than significant level.

**Mitigation Measure HAZ-1:** If evidence of contaminated soil and/or groundwater, such as discolored soil, odors or oil sheen, is encountered during the removal of on-site debris or during excavation and/or grading both on and off site, the construction contractors shall stop work and immediately inform the Campus. An environmental hazardous materials professional shall be contracted to conduct an on-site assessment. If the materials are determined to pose a risk to the public or construction workers, the construction contractor shall prepare and submit a remediation plan to the appropriate agency and comply with all federal, state, and local laws. Soil remediation methods could include excavation and on-site treatment, excavation and off-site treatment or disposal, and/or treatment without excavation. Remediation alternatives for cleanup of contaminated groundwater could include in-situ treatment, extraction and on-site treatment, or extraction and off-site treatment and/or disposal. Construction plans shall be modified or construction postponed to ensure that construction will not inhibit remediation activities and will not expose the public or construction workers to hazardous conditions.

e) The campus is not located within the immediate vicinity of the Reid-Hillview Airport. Given the distance of the campus from the airport, future development under the 2025 FMP would not place persons within an airport hazard zone. There would be no impact with regard to this criterion.

f) The campus is not located in the vicinity of a private airstrip, and there would be no impact with regard to this criterion.

g) The City of San José Emergency Operations Plan does not list Yerba Buena Road or San Felipe Road as emergency evacuation routes (City of San José 2004). In addition, construction of facilities identified in the 2025 FMP would occur within the boundaries of the campus, and thus would not impede traffic on roadways surrounding campus. In addition, the Campus would keep all campus roadways open during construction so that emergency response and evacuation is not affected. There would be no impact with regard to this criterion.

h) The EVC campus is not located in a Very High Fire Hazard Severity Zone, as designated by maps prepared by the California Department of Forestry and Fire Protection (Cal Fire 2008). There would be no impact with regard to this criterion.

#### Discussion of Potential Cumulative Impacts

Anticipated future development in San José has the potential to expose the public and the environment to risks associated with hazards from on-site contamination and routine use of hazardous materials. However, with mitigation, future development under the 2025 FMP would not expose the public and the environment to potential on-site contamination during construction. In addition, while the operation of campus facilities would involve the routine use of hazardous materials in small amounts, the use of these materials on campus would comply with all applicable local, state, and federal regulations. Therefore, the proposed project would not contribute to a cumulative impact during operation.



<b>Issues</b>	Potentially Significant Impact	Less than Significant with Project Mitigation	Less Than Significant Impact	No Impact
<b>9. HYDROLOGY AND WATER QUALITY – Would the project:</b>				
a) Violate any water quality standards or waste discharge requirements?	<input type="checkbox"/>	<input type="checkbox"/>	<input checked="" type="checkbox"/>	<input type="checkbox"/>
b) Substantially deplete groundwater supplies or interfere substantially with groundwater recharge such that there would be a net deficit in aquifer volume or a lowering of the local groundwater table level (e.g., the production rate of pre-existing nearby wells would drop to a level which would not support existing land uses or planned uses for which permits have been granted)?	<input type="checkbox"/>	<input type="checkbox"/>	<input checked="" type="checkbox"/>	<input type="checkbox"/>
c) Substantially alter the existing drainage pattern of the site or area, including through the alteration of the course of a stream or river, in a manner which would result in substantial erosion or siltation on- or of-site?	<input type="checkbox"/>	<input type="checkbox"/>	<input checked="" type="checkbox"/>	<input type="checkbox"/>
d) Substantially alter the existing drainage pattern of the site or area, including through the alteration of the course of a stream or river, or substantially increase the rate or amount of surface runoff in a manner which would result in flooding on- or off-site?	<input checked="" type="checkbox"/>	<input type="checkbox"/>	<input type="checkbox"/>	<input type="checkbox"/>
e) Create or contribute runoff water which would exceed the capacity of existing or planned stormwater drainage systems or provide substantial additional sources of polluted runoff?	<input checked="" type="checkbox"/>	<input type="checkbox"/>	<input type="checkbox"/>	<input type="checkbox"/>
f) Otherwise substantially degrade water quality?	<input type="checkbox"/>	<input type="checkbox"/>	<input type="checkbox"/>	<input checked="" type="checkbox"/>
g) Place housing within a 100-year flood hazard area as mapped on a federal Flood Hazard Boundary or Flood Insurance Rate Map or other flood hazard delineation map?	<input type="checkbox"/>	<input type="checkbox"/>	<input type="checkbox"/>	<input checked="" type="checkbox"/>
h) Place within a 100-year flood hazard area structures which would impede or redirect flood flows?	<input type="checkbox"/>	<input type="checkbox"/>	<input type="checkbox"/>	<input checked="" type="checkbox"/>

<b>Issues</b>	Potentially Significant Impact	Less than Significant with Project Mitigation	Less Than Significant Impact	No Impact
i) Expose people or structures to a significant risk of loss, injury or death involving flooding, including flooding as a result of the failure of a levee or dam?	<input type="checkbox"/>	<input type="checkbox"/>	<input type="checkbox"/>	<input checked="" type="checkbox"/>
j) Inundation by seiche, tsunami, or mudflow?	<input type="checkbox"/>	<input type="checkbox"/>	<input type="checkbox"/>	<input checked="" type="checkbox"/>

Relevant Elements of the Project and its Setting

The proposed project consists of the demolition of existing campus buildings and construction of replacement facilities identified in the 2025 FMP to meet future growth projections on the campus. Construction of individual buildings and facilities would include site grading and excavation. All runoff from pavements, roofs, and other impervious surfaces that are developed on campus flows and would continue to flow to Thompson Creek, which is located to the west of the campus across San Felipe Road. The campus is underlain by the Santa Clara groundwater basin (DWR 2003). The campus is not located within a 100-year flood plain or a flood inundation zone (FEMA 2009). The nearest body of water is the Cherry Flat Reservoir, located 4 miles northeast of the campus. The San Francisco Bay is located about 19 miles northwest of the campus.

Discussion of Potential Project Impacts

a) During construction of facilities identified in the 2025 FMP, there is a potential for increased erosion, sedimentation, and discharge of polluted runoff from the site. However, as identified in **Geology and Soils Item 6(b)**, the construction contractor would be required to implement a SWPPP including erosion and pollution control measures in compliance with NPDES regulations, or implement an erosion control plan as required by campus procedures to control increases in off-site sediment delivery. The impact to water quality from construction activities would therefore be less than significant.

The development of facilities identified in the 2025 FMP would increase the amount of impervious surfaces on the campus and would increase the amount of runoff generated on the campus. During operation, all site drainage would be routed to the City’s storm drain system, which would then discharge the flow to Thompson Creek. This runoff is subject to the conditions of the Municipal Regional Stormwater NPDES Permit No. CAS612008 for the San Francisco Bay Region. This permit requires permittees to comply with the discharge prohibitions and receiving water limitations through the timely implementation of control measures and other actions as specified in the permit (San Francisco Bay RWQCB, 2009). Future development on the campus would be required to comply with applicable NPDES requirements for stormwater quality. Therefore, implementation of the 2025 FMP would not result in any direct or indirect discharges that would violate water quality standards or waste discharge requirements. Impacts during operation would be less than significant with regard to this criterion.

b) The campus is underlain by the Santa Clara groundwater basin. However, the campus obtains its potable water supply from surface water supplies provided through the local water retailer. Therefore, the increase in potable water use on the campus from implementation of the 2025 FMP would not impact groundwater supplies. Natural recharge in the basin occurs principally as infiltration in streambeds that exit the upland areas within the drainage basin and from direct percolation of precipitation that falls on

the basin floor (DWR 2003). Implementation of the 2025 FMP would increase the amount of impervious surface on the campus. However, as this increase in impervious surface would be small, it would have a minimal effect on groundwater recharge. Impacts would be less than significant with regard to this criterion.

c) While the erosion potential of a majority of soils on the campus is none to slight, the erosion potential of soils on the northeastern portion of the campus is medium to high (SJECCD 2001). Storm water generated by future development under the 2025 FMP would be directed toward existing storm drainage facilities serving the campus. As discussed in **Geology and Soils Item 6(b)** above, each individual project on the campus would be required to control soil erosion and siltation during construction through either the preparation of a SWPPP if the project is 1 acre or more in size or the preparation of an erosion control plan if the project is less than 1 acre in size. Implementation of the SWPPP would reduce the potential for erosion on the construction sites and minimize the discharge of sediment into the storm drain system. Once the new or replacement facilities are constructed, the project sites would be either under impervious surfaces (buildings, pavement, etc.) or would be landscaped. This would minimize the potential for erosion and sedimentation in the long run. In addition, while the implementation of the 2025 FMP would increase the amount of impervious surface on the campus, this increase in impervious surface would be small. As a result, the amount of additional runoff entering the City's storm drain system would not be substantial enough to result in off-site erosion or siltation in downstream locations. Therefore, this impact is considered less than significant.

d) As discussed in the previous response above, storm water generated by future development under the 2025 FMP would be directed toward existing storm drainage facilities serving the campus. There are no existing flooding problems on the campus, and each project built on the campus would be designed to avoid on-site flooding. In addition, while the implementation of the 2025 FMP would increase the amount of impervious surface on the campus, this increase in impervious surface would be small. However, the amount of additional runoff entering the City's storm drain system could be substantial enough to contribute to existing flooding problems along Thompson Creek (SJECCD 2001). This represents a potentially significant impact. The EIR will analyze the potential impacts related to flooding on or near the campus.

e) Implementation of the 2025 FMP would increase impervious surfaces on campus, which could increase the volume of stormwater runoff in the City's storm drain system. Although this increase in runoff would be small, it could exceed the capacity of existing or planned stormwater drainage systems because of lack of capacity in Thompson Creek to accept stormwater runoff during flood conditions. This represents a potentially significant impact. The EIR will analyze the potential impacts related to stormwater system capacity.

See response to **Item 9(a)** above with regard to water quality. Implementation of the 2025 FMP would not provide substantial additional sources of polluted runoff. Therefore, this impact is considered less than significant.

f) See responses to **Items 9(a)** through **(d)**, above, and related discussions in the **Hazards and Hazardous Materials** Section of this checklist. No other potential project impacts to water quality were identified.

g-h) The campus is not located within a 100-year flood zone. The campus is located within Flood Zone D, which is defined as an area with undetermined flooding, but where flooding is possible (FEMA 2009). There are no existing residential uses on campus and no residential uses are included in the 2025 FMP. As

a result, implementation of the 2025 FMP would not place housing or structures within an area at risk of flood flows. There would be no impact with regard to this criterion.

i) The campus is not located within the dam inundation area for the Cherry Flats Reservoir (ABAG 1995). Therefore, implementation of the 2025 FMP would not expose people or structures to a significant risk of loss, injury or death involving flooding, including flooding as a result of the failure of a levee or dam. There would be no impact with regard to this criterion.

j) The campus is located well inland from the San Francisco Bay and no bodies of water are located in the vicinity of the campus. As a result, the campus is not at risk of seiche or tsunami inundation. Because of the location of the campus in flat topography there is no substantial risk of debris flow or mudflow. There would be no impact with regard to this criterion.

#### Discussion of Potential Cumulative Impacts

Anticipated future development in San José could result in the violation of water quality or waste discharge requirements during construction. However, construction projects in the City involving 1 acre or more of land disturbance are required to prepare and implement a SWPPP that includes erosion and pollution control measures and measures to control increases in off-site sediment delivery. Furthermore, construction projects on the campus would be required to adhere to NPDES requirements for construction activities. As a result, the cumulative impact with regard to water quality would be less than significant.

The construction and operation of facilities identified in the 2025 FMP combined with other current projects and probable future projects and projected regional growth could result in or contribute to flooding problems along local creeks. This issue will be addressed in the EIR.

Anticipated future development in San José could place housing or structures within a 100-year flood zone or within a tsunami inundation area. However, as the campus is not located within either a 100-year flood zone or within a tsunami inundation area, future development anticipated under the 2025 FMP would not contribute to this impact.

<b>Issues</b>	Potentially Significant Impact	Less than Significant with Project Mitigation	Less Than Significant Impact	No Impact
---------------	--------------------------------	---	------------------------------	-----------

**10. LAND USE AND PLANNING – Would the project:**

- |   |                                     |                          |                          |                                     |
|---|-------------------------------------|--------------------------|--------------------------|-------------------------------------|
| a) Physically divide an established community?  | <input type="checkbox"/>            | <input type="checkbox"/> | <input type="checkbox"/> | <input checked="" type="checkbox"/> |
| b) Conflict with any applicable land use plan, policy, or regulation of an agency with jurisdiction over the project (including, but not limited to the general plan, specific plan, local coastal program, or zoning ordinance) adopted for the purpose of avoiding or mitigating an environmental effect? | <input checked="" type="checkbox"/> | <input type="checkbox"/> | <input type="checkbox"/> | <input type="checkbox"/>            |
| c) Conflict with any applicable habitat conservation plan or natural community conservation plan?   | <input type="checkbox"/>            | <input type="checkbox"/> | <input type="checkbox"/> | <input checked="" type="checkbox"/> |

Relevant Elements of the Project and its Setting

The proposed project consists of the demolition of existing campus buildings and construction of replacement facilities identified in the 2025 FMP to meet future growth projections on the campus.

Discussion of Potential Project Impacts

- a) Implementation of the 2025 FMP would not physically divide an established community since the campus already exists, and future development on the campus would occur with campus boundaries. There would be no impact with regard to this criterion.
- b) The SJECCD is not subject to local plans, policies, or regulations. However, SJECCD is required by Section 15125(d) of the *State CEQA Guidelines* to address inconsistencies between its proposed project and applicable general plans, specific plans, and regional plans. It is generally the policy of the SJECCD to be consistent with local and regional plans, policies, or regulations to the maximum extent possible. Any conflict between the 2025 FMP and applicable local and regional plans could result in a potentially significant impact. The EIR will discuss the consistency of the 2025 FMP with applicable regional plans which include the Bay Area 2010 Clean Air Plan, State Water Quality Control Board NPDES Permit, Santa Clara Valley Urban Runoff Pollution Prevention Program, and Santa Clara County Congestion Management Program.
- c) There is no habitat conservation plan or natural community conservation plan applicable to the campus. There would be no impact related to this criterion.

Discussion of Potential Cumulative Impacts

The proposed project combined with other current projects and probable future projects and projected regional growth could result in significant cumulative impacts with regard to consistency with regional plans. This issue will be addressed in the EIR.

<b>Issues</b>	Potentially Significant Impact	Less Than Significant with Mitigation Incorporated	Less Than Significant Impact	No Impact
---------------	--------------------------------	--	------------------------------	-----------

**11. MINERAL RESOURCES – Would the project:**

a) Result in the loss of availability of a known mineral resource that would be of value to the region and the residents of the state?

b) Result in the loss of availability of a locally important mineral resource recovery site delineated on a local general plan, specific plan or other land use plan?

Relevant Elements of the Project and its Setting

The proposed project consists of the demolition of existing campus buildings and construction of replacement facilities identified in the 2025 FMP to meet future growth projections on the campus. The City of San José 2020 General Plan does not designate the campus vicinity as a mineral resource area (San José 1994).

Discussion of Potential Project Impacts

a, b) The campus is not designated as a mineral resource area, and no known or potential mineral resources are located on the campus. In addition, existing land uses preclude the use of the campus for mineral extraction (e.g., sand and gravel). Therefore, future development on the campus would not impede extraction or result in the loss of availability of a known mineral resource. There would be no impacts with regard to these criteria.

Discussion of Potential Cumulative Impacts

The City of San José is urban in nature, and minerals are not found to any appreciable extent in the City. As a result, anticipated future development in San José, including future development on the campus under the 2025 FMP, would not result in the loss of availability of mineral resources. The cumulative impact would be less than significant.

<b>Issues</b>	Potentially Significant Impact	Less than Significant with Project Mitigation	Less Than Significant Impact	No Impact
12. NOISE – Would the project result in:				
a) Exposure of persons to or generation of noise levels in excess of standards established in any applicable plan or noise ordinance, or applicable standards of other agencies?	■	<input type="checkbox"/>	<input type="checkbox"/>	<input type="checkbox"/>
b) Exposure of persons to or generation of excessive groundborne vibration or groundborne noise levels?	■	<input type="checkbox"/>	<input type="checkbox"/>	<input type="checkbox"/>
c) A substantial permanent increase in ambient noise levels in the project vicinity above levels existing without the project?	■	<input type="checkbox"/>	<input type="checkbox"/>	<input type="checkbox"/>
d) A substantial temporary or periodic increase in ambient noise levels in the project vicinity above levels existing without the project (including construction)?	■	<input type="checkbox"/>	<input type="checkbox"/>	<input type="checkbox"/>
e) For a project located within an airport land use plan or, where such a plan has not been adopted, within 2 miles of a public airport or public use airport, would the project expose people residing or working in the project area to excessive noise levels?	<input type="checkbox"/>	<input type="checkbox"/>	<input type="checkbox"/>	■
f) For a project within the vicinity of a private airstrip, would the project expose people residing or working in the project area to excessive noise levels?	<input type="checkbox"/>	<input type="checkbox"/>	<input type="checkbox"/>	■

Relevant Elements of the Project and its Setting

The proposed project consists of the demolition of existing campus buildings and construction of replacement facilities identified in the 2025 FMP to meet future growth projections on the campus. Construction of each individual facility would generate noise, and once construction is completed, the operation of each individual facility would add to current sources of traffic noise by redirecting and rerouting vehicle trips to nearby roadways. The nearest sensitive receptors to the campus include single-family residential uses to the north, south, and west of the campus. Other sensitive receptors in the vicinity of the campus include Evergreen Park and Church on the Rock - Baptist to the south; Montgomery Hill Park to the east; and an assisted-living facility to the west. The nearest airport is Reid-Hillview Airport, located approximately 4 miles to the northwest of the campus.

#### Discussion of Potential Project Impacts

a) Implementation of the 2025 FMP could result in increases or changes in noise levels from sources such as construction activities, stationary sources, and increased vehicular traffic, which could exceed applicable noise standards. For example, construction activity or new stationary sources could exceed State's exterior noise standard of 70 A-weighted decibels (dB(A)) community noise equivalent level (CNEL) for schools. These impacts are considered potentially significant. The EIR will evaluate the potential for facilities identified in the 2025 FMP to expose people to noise in excess of State standards.

b) Construction activities associated with the 2025 FMP could generate excessive groundborne vibration and noise on and near the campus. This represents a potentially significant impact. The EIR will evaluate the potential for increased groundborne vibration or noise levels associated with construction of facilities identified in the 2025 FMP to affect nearby sensitive receptors.

c) Vehicle traffic associated with facilities identified in the 2025 FMP could result in substantial permanent increases in ambient noise levels in the vicinity of the project site. These impacts are considered potentially significant. The EIR will evaluate the potential for facilities identified in the 2025 FMP to permanently increase ambient noise levels.

d) Construction activities associated with the 2025 FMP could result in substantial temporary increases in ambient noise levels on campus and in the vicinity of the project. These impacts are considered potentially significant. The EIR will evaluate the potential for the construction of facilities identified in the 2025 FMP to temporarily increase ambient noise levels.

e) The campus is not located within the immediate vicinity of an airport. Other than aircraft overflights, the project site would not be exposed to noise from public airports. There would be no impact with respect to this criterion.

f) The proposed project is not located in the vicinity of a private airstrip, and there would be no impact with regard to this criterion.

#### Discussion of Potential Cumulative Impacts

Future development under the 2025 FMP combined with other current projects and probable future projects and projected regional growth could result in significant cumulative noise impacts. This issue will be addressed in the EIR.



<b>Issues</b>	Potentially Significant Impact	Less than Significant with Project Mitigation	Less Than Significant Impact	No Impact
---------------	--------------------------------	---	------------------------------	-----------

**13. POPULATION AND HOUSING – Would the project:**

a) Induce substantial population growth in an area, either directly (for example, by proposing new homes and businesses) or indirectly (for example, through extension of roads or other infrastructure)?	<input type="checkbox"/>	<input type="checkbox"/>	<input checked="" type="checkbox"/>	<input type="checkbox"/>
b) Displace substantial numbers of existing housing, necessitating the construction of replacement housing elsewhere?	<input type="checkbox"/>	<input type="checkbox"/>	<input type="checkbox"/>	<input checked="" type="checkbox"/>
c) Displace substantial numbers of people, necessitating the construction of replacement housing elsewhere?	<input type="checkbox"/>	<input type="checkbox"/>	<input type="checkbox"/>	<input checked="" type="checkbox"/>

Relevant Elements of the Project and its Setting

The proposed project consists of the demolition of existing campus buildings and construction of replacement facilities identified in the 2025 FMP to meet future growth projections on the campus. Implementation of the 2025 FMP would accommodate an increase in enrollment on campus from approximately 12,000 to 14,850 students by 2025. A corresponding increase in faculty and staff on the campus is also anticipated.

Discussion of Potential Project Impacts

- a) The EVC campus does not provide housing for students, faculty, or staff, and students and employees commute to the campus from the surrounding communities. As enrollment grows, more students will commute to the campus from the surrounding communities; it is unlikely that students would move into the San Jose area with the single purpose of being closer to campus. New faculty and staff required to serve the increase in enrollment would likely be living in the Bay Area at the time of hire and even if some of them are new to the Bay Area, they could live anywhere in the region and commute to the campus. Therefore, it is unlikely that a substantial number of students or employees would be added to the San Jose area as a result of project implementation. Therefore, this impact is considered less than significant.
- b) The campus is currently developed with academic and related uses. No housing exists on the campus, and there would be no impact with respect to this criterion.
- c) See response to **Item 13(b)**, above. There would be no impact with regard to this criterion.

Discussion of Potential Cumulative Impacts

Anticipated future development in San José would result in an increase in population throughout the City, which could result in an overall population that exceeds population projections. As discussed above, the increase in San Jose area population as a result of 2025 FMP implementation would not be substantial. Therefore, the contribution of the 2025 FMP to this impact would not be cumulatively considerable.

<b>Issues</b>	Potentially Significant Impact	Less than Significant with Project Mitigation	Less Than Significant Impact	No Impact
---------------	--------------------------------	---	------------------------------	-----------

**14. PUBLIC SERVICES** – Would the project:

Would the project result in substantial adverse physical impacts associated with the provision of new or physically altered governmental facilities, need for new or physically altered governmental facilities, the construction of which could cause significant environmental impacts, in order to maintain acceptable service ratios, response times or other performance objectives for any of the public services:

a) Fire protection?	<input checked="" type="checkbox"/>	<input type="checkbox"/>	<input type="checkbox"/>	<input type="checkbox"/>
b) Police protection?	<input checked="" type="checkbox"/>	<input type="checkbox"/>	<input type="checkbox"/>	<input type="checkbox"/>
c) Schools?	<input type="checkbox"/>	<input type="checkbox"/>	<input checked="" type="checkbox"/>	<input type="checkbox"/>
d) Parks?	<input type="checkbox"/>	<input type="checkbox"/>	<input checked="" type="checkbox"/>	<input type="checkbox"/>
e) Other public facilities?	<input type="checkbox"/>	<input type="checkbox"/>	<input checked="" type="checkbox"/>	<input type="checkbox"/>

Relevant Elements of the Project and its Setting

The proposed project consists of the demolition of existing campus buildings and construction of replacement facilities identified in the 2025 FMP to meet future growth projections on the campus. The City of San José Fire Department provides fire protection services to the campus. The San José/Evergreen Valley Community College District (SJECCD) Police Department provides law enforcement services to the campus. The closest parks to the campus are Montgomery Hill Park, Falls Creek Park, and Evergreen Park. Montgomery Hills Park is located adjacent to the campus to the east, Falls Creek Park is located approximately 1,000 feet northwest of the campus, and Evergreen Park is located about 1,000 feet southeast of the campus. The closest off-campus library, the Evergreen Branch Library, is located approximately 2 miles from the campus.

Discussion of Potential Project Impacts

a) Implementation of the 2025 FMP would result in additional facilities and population on the campus. This increase in campus facilities and population could place additional demand on the San José Fire Department for fire protection services, and may result in the need for new or expanded fire protection facilities, the construction of which could result in significant environmental impacts. This impact is considered potentially significant, and will be further analyzed in the EIR.

b) Implementation of the 2025 FMP may include the expansion of the existing SJECCD Police Department facility on campus. The EIR will analyze the biological, air quality, and noise effects of expanding the SJECCD Police Department facility along with the biological, air quality and noise effects of the other

facilities under the 2025 FMP. The potential effects on cultural resources from constructing new or expanded facilities, including the SJECCD Police Department facility, are addressed in **Item 5**, above.

c) No residential uses are associated with the 2025 FMP. Therefore, future development on the campus would not result in a direct impact on schools due to an increase in residential population. As noted in response to **Item 13(a)** above, new students, faculty, and staff associated with the 2025 FMP would likely be living in the surrounding communities or in the wider Bay Area at the time of enrollment or hire. To the extent that new students or employees move into Bay Area communities to study or work at the college, their numbers would not be large and would not add a substantial number of school age students to any one community. This impact is considered less than significant.

d) No residential uses are associated with the 2025 FMP. Therefore, future development on the campus would not result in a direct impact on parks due to an increase in residential population. Three parks are located in the immediate vicinity of the campus. Due to their proximity, it is possible that some students, faculty, and staff could utilize these facilities. However, existing recreational facilities are located on the campus and future recreational facilities identified in the 2025 FMP would be available to meet the needs of the campus population. Therefore, the use of off-campus parks is expected to be minimal and the impact of the campus population on existing parks in the vicinity of the campus would be less than significant.

e) No residential uses are associated with the 2025 FMP. Therefore, future development on the campus would not result in a direct impact on other public facilities such as libraries due to an increase in residential population. The closest off-campus library is located approximately 2 miles from the campus. Due to the distance, it is unlikely that students, faculty, and staff would utilize this facility. In addition, the campus has an existing library that is available to the campus population for use. For this reasons, the impact on public libraries would be less than significant.

#### Discussion of Potential Cumulative Impacts

Future development under the 2025 FMP combined with other current projects and probable future projects and projected regional growth could result in significant cumulative impacts with regard to fire protection services provided by the San Jose City Fire Department. This issue will be addressed in the EIR.

Future development under the 2025 FMP combined with future development on the San Jose City College campus could result in significant cumulative impacts with regard to police protection services provided by the SJECCD Police Department. This issue will be addressed in the EIR.

Although substantial portions of the City are built out, future development or redevelopment would increase population in the City, thus resulting in an increase in demand for schools, parks and other public facilities such as libraries. As a result of the increased demand, future growth in the City may require new or physically altered facilities to accommodate staff and equipment to meet increased demand, the construction of which could cause significant environmental impacts. As the 2025 FMP does not include a residential component, the proposed project would not have any direct impacts on schools, parks, or libraries. For reasons presented in responses to **Items 14 (c), (d), and (e)** above, any indirect impacts would be minimal. Therefore, the project's contribution to the cumulative impact would not be cumulatively considerable.

<b>Issues</b>	Potentially Significant Impact	Less than Significant with Project Mitigation	Less Than Significant Impact	No Impact
---------------	--------------------------------	---	------------------------------	-----------

**15. RECREATION** – Would the project:

- |  |                                     |                          |                                     |                          |
|--|-------------------------------------|--------------------------|-------------------------------------|--------------------------|
| a) Would the project increase the use of existing neighborhood and regional parks or other recreational facilities such that substantial physical deterioration of the facility would occur or be accelerated? | <input type="checkbox"/>            | <input type="checkbox"/> | <input checked="" type="checkbox"/> | <input type="checkbox"/> |
| b) Does the project include recreational facilities or require the construction or expansion of recreational facilities, which might have an adverse physical effect on the environment?                       | <input checked="" type="checkbox"/> | <input type="checkbox"/> | <input type="checkbox"/>            | <input type="checkbox"/> |

Relevant Elements of the Project and its Setting

The proposed project consists of the demolition of existing campus buildings and construction of replacement facilities identified in the 2025 FMP to meet future growth projections on the campus. Under the 2025 FMP, the racquetball courts would be demolished while a new fitness center would be constructed. The closest parks to the campus are Montgomery Hill Park, Falls Creek Park, and Evergreen Park.

Discussion of Potential Project Impacts

a) See the response to **Item 14(d)** above. Given the presence of existing recreational facilities on the campus and the construction of future facilities identified in the 2025 FMP, the increase in campus population under the 2025 FMP would not result in an increase in the use of existing neighborhood and regional parks or other recreational facilities such that substantial physical deterioration of existing facilities would occur or be accelerated. Therefore, the impact on recreational facilities would be less than significant.

b) No public parks or recreational facilities would be constructed as part of the 2025 FMP. The 2025 FMP includes recreational facilities for use by the campus and community, the construction of which could result in adverse physical effects on the environment. The EIR will analyze the biological, air quality, and noise effects of constructing these recreational facilities. The effects to cultural resources of constructing the proposed facilities included in the 2025 FMP, including these recreational facilities, are addressed above in **Item 5**.

Discussion of Potential Cumulative Impacts

Anticipated future development in San José would increase the extent of development in the City, thus resulting in a cumulative increase in the use of recreational facilities. As a result, future growth in the City may cause substantial physical deterioration of recreational facilities to occur or be accelerated, or may require the construction or expansion of recreational facilities, the construction of which could cause significant environmental impacts. As discussed above, no residential population is associated with 2025 FMP that would require parks or other City recreational facilities and existing and future recreational facilities on the campus would serve the campus population. Therefore, the project would not make a substantial contribution to the cumulative impact with regard to the deterioration of recreational

facilities. However, the 2025 FMP does include recreational facilities, the construction of which could cause significant biological, air quality, or noise impacts, which could combine with the construction-phase impacts of other concurrent projects thus resulting in significant cumulative environmental impacts. This issue will be addressed in the EIR.

<b>Issues</b>	Potentially Significant Impact	Less than Significant with Project Mitigation	Less Than Significant Impact	No Impact
<b>16. TRANSPORTATION/TRAFFIC</b> – Would the project:				
a) Conflict with an applicable plan, ordinance or policy establishing measures of effectiveness for the performance of the circulation system, taking into account all modes of transportation and relevant components of the circulation system, including but not limited to intersections, streets, highways, and freeways, pedestrian and bicycle paths, and mass transit?	■	□	□	□
b) Conflict with an applicable congestion management program, including, but not limited to level of service standards and travel demand measures, or other standards established by the county congestion management agency for designated roads or highways?	■	□	□	□
c) Result in a change in air traffic patterns, including either an increase in traffic levels or a change in location that results in substantial safety risks?	□	□	□	■
d) Substantially increase hazards due to a design feature (e.g., sharp curves or dangerous intersections) or incompatible uses (e.g., farm equipment)?	■	□	□	□
e) Result in inadequate emergency access?	■	□	□	□
f) Conflict with adopted policies, plans, or programs regarding public transit, bicycle, or pedestrian facilities, or otherwise decrease the performance or safety of such facilities?	■	□	□	□

Relevant Elements of the Project and its Setting

The proposed project consists of the demolition of existing campus buildings and construction of replacement facilities identified in the 2025 FMP to meet future growth projections on the campus. The campus is 2.5 miles east of the US 101. Roadways that serve the campus include Yerba Buena Road to the south and San Felipe Road to the west. Yerba Buena Road is designated as a major collector while San Felipe Road is designated as an arterial roadway by the City of San José 2020 *General Plan* (City of San José 1994).

Discussion of Potential Project Impacts

a-b) Implementation of the 2025 FMP could potentially cause an increase in traffic on surrounding roadways or redirect traffic that is already in the area. These potential changes in traffic and circulation in the vicinity of the campus could result in congestion. This represents a potentially significant impact. A

detailed Traffic Impact Study will be prepared to evaluate the impacts of the 2025 FMP on local roadway capacity and this issue will be addressed in the EIR.

c) The 2025 FMP does not include uses that would affect air traffic or result in changes to air patterns. There would be no impact with regard to this criterion.

d) The 2005 FMP includes recommended vehicular and pedestrian circulation plans. The proposed design of the circulation plans could result in pedestrian and vehicle conflicts on the campus. This represents a potentially significant impact. The effects of the recommended vehicular and pedestrian circulation plans on public safety will be analyzed in the EIR.

e) Implementation of the 2025 Facilities Master Plan would result in the construction of new buildings and new roadways on the EVC campus, thus requiring emergency access. The issue of emergency access considers both the regional accessibility of the campus and access within the campus itself. From a regional perspective, the accessibility for emergency vehicles is more than adequate. Once emergency vehicles have traveled to the campus, the internal roadway network is adequate to allow these vehicles to reach their designated locations. Implementation of the 2025 FMP would improve existing circulation on campus by adding a new loop road to the northern portion of campus. As a result, implementation of the 2025 Facilities Master Plan would not result in inadequate emergency access and this impact is considered less than significant.

f) The EIR will describe the existing adopted policies, plans, and/or programs supporting alternative transportation on the campus. Any conflicts between the 2025 FMP and alternative transportation represent a potentially significant impact. The effects of the 2025 FMP on alternative transportation will be analyzed in the EIR.

#### Discussion of Potential Cumulative Impacts

Implementation of the 2025 FMP combined with other current projects and probable future projects and projected regional growth could result in significant cumulative impacts with regard to transportation/traffic. This issue will be addressed in the EIR.

<b>Issues</b>	Potentially Significant Impact	Less than Significant with Project Mitigation	Less Than Significant Impact	No Impact
<b>17. UTILITIES AND SERVICE SYSTEMS – Would the project:</b>				
a) Exceed wastewater treatment requirements of the applicable Regional Water Quality Control Board?	■	<input type="checkbox"/>	<input type="checkbox"/>	<input type="checkbox"/>
b) Require or result in the construction of new water or wastewater treatment facilities or expansion of existing facilities, the construction of which could cause significant environmental effects?	■	<input type="checkbox"/>	<input type="checkbox"/>	<input type="checkbox"/>
c) Require or result in the construction of new storm water drainage facilities or expansion of existing facilities, the construction of which could cause significant environmental effects?	■	<input type="checkbox"/>	<input type="checkbox"/>	<input type="checkbox"/>
d) Have sufficient water supplies available to serve the project from existing entitlements and resources, or are new or expanded entitlements needed?	■	<input type="checkbox"/>	<input type="checkbox"/>	<input type="checkbox"/>
e) Result in a determination by the wastewater treatment provider which serves or may serve the project, that it has inadequate capacity to serve the project's projected demand in addition to the provider's existing commitments?	■	<input type="checkbox"/>	<input type="checkbox"/>	<input type="checkbox"/>
f) Be served by a landfill with sufficient permitted capacity to accommodate the project's solid waste disposal needs?	■	<input type="checkbox"/>	<input type="checkbox"/>	<input type="checkbox"/>
g) Comply with applicable federal, state, and local statutes and regulations related to solid waste?	■	<input type="checkbox"/>	<input type="checkbox"/>	<input type="checkbox"/>

Relevant Elements of the Project and its Setting

The proposed project consists of the demolition of existing campus buildings and construction of replacement facilities identified in the 2025 FMP to meet future growth projections on the campus. Wastewater generated on the campus is treated at the San José/Santa Clara Water Pollution Control Plant (WPCP). Potable water is supplied to the campus by the San Jose Municipal Water System.

Discussion of Potential Project Impacts

a) The San Francisco Bay Regional Water Quality Control Board (RWQCB) regulates water quality and quantity of effluent discharged from the WPCP. Implementation of the 2025 FMP would increase the volume of wastewater received at the WPCP for treatment. Any exceedance of treatment requirements at the WPCP due to the increase in wastewater from the campus under the 2025 FMP would result in a



potentially significant impact. The effects of campus development under the 2025 FMP on the ability of the WPCP to meet wastewater treatment requirements set by the San Francisco Bay RWQCB will be analyzed in the EIR.

b, e) Implementation of the 2025 FMP would result in an increase in water use and generation of wastewater. This increase may result in the need for new water or wastewater treatment and conveyance facilities or the expansion of existing facilities, the construction of which could cause significant environmental effects. This represents a potentially significant impact. The effects of the 2025 FMP on existing water and wastewater treatment facilities will be analyzed in the EIR.

c) Implementation of the 2025 FMP would increase impervious surfaces on the campus, which could increase the volume of stormwater drainage conveyed to existing stormwater facilities. Although the increase would be relatively small, the amount of stormwater drainage generated on campus could exceed the capacity of existing stormwater facilities, due to existing capacity constraints. New storm drain facilities may be required, the construction of which could cause significant environmental effects. This represents a potentially significant impact. The effects of the 2025 FMP on existing stormwater facilities will be analyzed in the EIR.

d) Implementation of the 2025 FMP would result in an increase in demand for water on the campus and this demand may exceed the amount of water available to the San Jose Municipal Water System from existing entitlements and resources. This represents a potentially significant impact. The effects of the 2025 FMP on existing water entitlement and resources will be analyzed in the EIR.

f, g) Implementation of the 2025 FMP could result in an increase in solid waste generated on the campus. Recology Silicon Valley collects and disposes of solid waste that is generated by the campus. The amount of solid waste generated on the campus requiring disposal could potentially exceed the capacity of local landfills. In addition, implementation of the 2025 FMP could conflict with applicable federal, state, and local statutes and regulations related to solid waste. This represents a potentially significant impact. The effects of the 2025 FMP on landfill capacity and compliance with applicable regulations will be analyzed in the EIR.

#### Discussion of Potential Cumulative Impacts

Implementation of the 2025 FMP combined with other current projects and probable future projects and projected regional growth could result in significant cumulative impacts with regard to utilities. This issue will be addressed in the EIR.

<b>Issues</b>	Potentially Significant Impact	Less than Significant with Project Mitigation	Less Than Significant Impact	No Impact
---------------	--------------------------------	---	------------------------------	-----------

**18. MANDATORY FINDINGS OF SIGNIFICANCE – Would the project:**

a) Does the project have the potential to degrade the quality of the environment, substantially reduce the habitat of a fish or wildlife species, cause a fish or wildlife population to drop below self-sustaining levels, threaten to eliminate a plant or animal community, substantially reduce the number or restrict the range of a rare or endangered plant or animal or eliminate important examples of the major periods of California history or prehistory?

b) Does the project have impacts that are individually limited, but cumulatively considerable? (“Cumulatively considerable” means that the incremental effects of a project are significant when viewed in connection with the effects of past projects, the effects of other current projects, and the effects of past, present and probable future projects)?

c) Does the project have environmental effects which will cause substantial adverse effects on human beings, either directly or indirectly?

Discussion of Potential Project Impacts

a) Please refer to responses under Biological Resources **Items 4(a)** through **(f)**, and Cultural Resources **Items 5(a)** through **(d)**, above. While future development on the campus could eliminate examples of California history or prehistory, implementation of mitigation measures identified in this Initial Study would reduce all impacts to a less than significant level. However, future development on campus could significantly affect fish or wildlife habitat. This impact is considered potentially significant. The EIR will identify and analyze potential impacts to fish and wildlife habitat.

b) An analysis of whether the potential impacts of the proposed project combined with other current projects and probable future projects and projected regional growth in the surrounding area would result in significant cumulative impacts will be included in the EIR.

c) As indicated in the preceding discussion, implementation of the 2025 FMP has the potential to result in potentially significant impacts. An evaluation of whether any of those impacts would have the potential to result in substantial effects to human beings will be included in the EIR.

## VI. SUPPORTING INFORMATION SOURCES

### VI. SUPPORTING INFORMATION SOURCES

Association of Bay Area Governments. 1995. Dam Failure Inundation Hazard Map for San José. ABAG 1995

California Department of Conservation, California Geological Survey, State of California Seismic Hazard Zones, San José East Quadrangle, 2001.

California Department of Conservation, California Geological Survey. Alquist-Priolo Earthquake Fault Zone Maps. Accessed May 17, 2011. [http://www.quake.ca.gov/gmaps/ap/ap\\_maps.htm](http://www.quake.ca.gov/gmaps/ap/ap_maps.htm). (GCS 2011)

California Department of Conservation, Division of Land Resource Protection, Farmland Mitigation and Monitoring Program. 2011. Santa Clara County Important Farmland 2010. (FMMP 2011)

California Department of Forestry and Fire Prevention. 2008. Santa Clara County Fire Hazard Safety Zone Map – Local Area of Responsibility. Available at [http://fire.ca.gov/fire\\_prevention/fhsz\\_maps/fhsz\\_maps\\_santaclara.php](http://fire.ca.gov/fire_prevention/fhsz_maps/fhsz_maps_santaclara.php). (Cal Fire 2008)

California Department of Transportation, California Scenic Highway Program. Accessed August 31, 2011. California Department of Water Resources. 2003. California's Groundwater - Bulletin 118, Update 2003. (DWR 2003)

City of San José. 1994. City of San José 2020 General Plan, as amended 2008. (City of San José 1994)  
City of San José. 2004. City of San José Emergency Operation Plan. (City of San José 2004)

Environmental Data Resources, Inc. 2011. EDR Radius Map Report with Geotech, Evergreen Valley College. June 8. (EDR 2011)

Federal Emergency Management Agency. May 18, 2009. Flood Insurance Rate Map No. 06085C0267H for Santa Clara County, California. (FEMA 2009)

Northwest Information Center. 2011. Records search results for the proposed Evergreen Valley College 2025 Facilities Master Plan Project, San José, California. (NWIC 2011)

San Francisco Bay Regional Water Quality Control Board. 2009. California Regional Water Quality Control Board San Francisco Bay Region Municipal Regional Stormwater NPDES Permit, Order R2-2009-0074, NPDES Permit No. CAS612008. (San Francisco Bay RWQCB, 2009)

San José/Evergreen Community College Distract. 2001. Evergreen Valley College Facilities Master Plan Final Environmental Impact Report. SCH No. 2000112004. (SJECCD 2001)

San José/Evergreen Community College District. 2000. Initial Study for Evergreen Valley College Facilities Master Plan. (SJECCD 2000)

URS. 2011. Memorandum from Mark E. Schmoll, Senior Project Geologist, URS and L. Allen Moore, Geotechnical Project Manager, URS to Mark A. Miller, Senior Project Executive, Gilbane Building Company regarding Clarification of Evergreen Fault Status. August 17. (URS 2011)

## **VII. INITIAL STUDY PREPARERS**

### **San José/Evergreen Community College District**

Mr. Douglas Smith, Vice Chancellor

Mark A. Miller, Senior Project Executive, Gilbane Companies

### **Impact Sciences, Inc.**

Shabnam Barati, Ph.D., Managing Principal

Elizabeth Purl, Senior Project Manager

Paul Stephenson, Project Manager

Ian Hillway, Publications Manager

Lisa Cuoco, Publications Coordinator





EDMUND G. BROWN JR.  
GOVERNOR

STATE OF CALIFORNIA  
GOVERNOR'S OFFICE of PLANNING AND RESEARCH  
STATE CLEARINGHOUSE AND PLANNING UNIT

*Pls. keep on file - re. EUC / EIR*



KEN ALEX  
DIRECTOR

Notice of Preparation

July 10, 2012

To: Reviewing Agencies

Re: Evergreen Valley College Facilities Master Plan  
SCH# 2000112004



Attached for your review and comment is the Notice of Preparation (NOP) for the Evergreen Valley College Facilities Master Plan draft Environmental Impact Report (EIR).

Responsible agencies must transmit their comments on the scope and content of the NOP, focusing on specific information related to their own statutory responsibility, within 30 days of receipt of the NOP from the Lead Agency. This is a courtesy notice provided by the State Clearinghouse with a reminder for you to comment in a timely manner. We encourage other agencies to also respond to this notice and express their concerns early in the environmental review process.

Please direct your comments to:

**Douglas Smith**  
San Jose-Evergreen Community College District  
4750 San Felipe Road  
San Jose, CA 95135-1599

with a copy to the State Clearinghouse in the Office of Planning and Research. Please refer to the SCH number noted above in all correspondence concerning this project.

If you have any questions about the environmental document review process, please call the State Clearinghouse at (916) 445-0613.

Sincerely,

Scott Morgan  
Director, State Clearinghouse

Attachments  
cc: Lead Agency

**Document Details Report  
State Clearinghouse Data Base**

**SCH#** 2000112004  
**Project Title** Evergreen Valley College Facilities Master Plan  
**Lead Agency** San Jose-Evergreen Community College District

---

**Type** **NOP** Notice of Preparation  
**Description** The 2025 Facilities Master Plan (FMP) involves reorganization of campus facilities and reconfiguration of campus access and circulation. Facility improvements contained in the 2025 FMP include (1) the demolition/removal of existing building on campus; (2) the construction of new buildings on campus; and (3) the renovation of existing buildings on campus to meet the future programs needs as outlined in 2025 Educational Master Plan.

---

**Lead Agency Contact**

**Name** Douglas Smith  
**Agency** San Jose-Evergreen Community College District  
**Phone** 408 270 6428 **Fax** (408) 238-2866  
**email**  
**Address** 4750 San Felipe Road  
**City** San Jose **State** CA **Zip** 95135-1599

---

**Project Location**

**County** Santa Clara  
**City** San Jose  
**Region**  
**Cross Streets** San Felipe Road, Yerba Buena Road  
**Lat / Long**  
**Parcel No.** 660-21-022  
**Township** **Range** **Section** **Base**

---

**Proximity to:**

**Highways** Hwy 101  
**Airports**  
**Railways**  
**Waterways**  
**Schools**  
**Land Use** Community College Campus / Urban land use designation

---

**Project Issues** Aesthetic/Visual; Agricultural Land; Air Quality; Archaeologic-Historic; Biological Resources; Flood Plain/Flooding; Geologic/Seismic; Minerals; Noise; Population/Housing Balance; Public Services; Recreation/Parks; Schools/Universities; Sewer Capacity; Soil Erosion/Compaction/Grading; Toxic/Hazardous; Traffic/Circulation; Vegetation; Water Quality; Water Supply; Wildlife; Growth Inducing; Landuse; Cumulative Effects

---

**Reviewing Agencies** Resources Agency; Office of Historic Preservation; Department of Parks and Recreation; Resources, Recycling and Recovery; Department of Water Resources; Department of Fish and Game, Region 3; CA Department of Public Health; Native American Heritage Commission; California Highway Patrol; Caltrans, District 4; Department of Toxic Substances Control; Regional Water Quality Control Board, Region 2

---

**Date Received** 07/10/2012 **Start of Review** 07/10/2012 **End of Review** 08/08/2012



Resources Agency

Resources Agency  
Nadell Gayou

Dept. of Boating & Waterways  
Nicole Wong

California Coastal Commission  
Elizabeth A. Fuchs

Colorado River Board  
Gerald R. Zimmerman

Dept. of Conservation  
Elizabeth Carpenter

California Energy Commission  
Eric Knight

Cal Fire  
Dan Foster

Central Valley Flood Protection Board  
James Herota

Office of Historic Preservation  
Ron Parsons

Dept of Parks & Recreation Environmental Stewardship Section

California Department of Resources, Recycling & Recovery  
Sue O'Leary

S.F. Bay Conservation & Dev't. Comm.  
Steve McAdam

Dept. of Water Resources Agency  
Nadell Gayou

Fish and Game

Dept. of Fish & Game  
Scott Flint

Fish & Game Region 1  
Donald Koch

Fish & Game Region 1E  
Laurie Harnsberger

Fish & Game Region 2  
Jeff Drongenes

Fish & Game Region 3  
Charles Armor

Fish & Game Region 4  
Julie Vance

Fish & Game Region 5  
Leslie Newton-Reed

Fish & Game Region 6  
Gabrina Gatchel

Fish & Game Region 6 I/M  
Brad Henderson

Inyo/Mono, Habitat Conservation Program  
Eric Knight

Dept. of Fish & Game M  
George Isaac  
Marine Region

Other Departments

Food & Agriculture  
Sandra Schubert  
Dept. of Food and Agriculture

Dept. of General Services  
Public School Construction

Dept. of General Services  
Anna Garbeff  
Environmental Services Section

Dept. of Public Health  
Bridgette Binning  
Dept. of Health/Drinking Water

Delta Stewardship Council  
Kevan Samsam

Independent Commissions, Boards

Delta Protection Commission  
Michael Machado

Cal EMA (Emergency Management Agency)  
Dennis Castrillo

Native American Heritage Comm.  
Debbie Treadway

Public Utilities Commission  
Leo Wong

Santa Monica Bay Restoration  
Guangyu Wang

State Lands Commission  
Jennifer Delsong

Tahoe Regional Planning Agency (TRPA)  
Cherry Jacques

Business, Trans & Housing

Caltrans - Division of Aeronautics  
Philip Cirimmins

Caltrans - Planning  
Terri Pencovic

California Highway Patrol  
Suzann Ikeuchi  
Office of Special Projects

Housing & Community Development  
CEQA Coordinator  
Housing Policy Division

Dept. of Transportation

Caltrans, District 1  
Rex Jackman

Caltrans, District 2  
Marcelino Gonzalez

Caltrans, District 3  
Gary Arnold

Caltrans, District 4  
Erik Alm

Caltrans, District 5  
David Murray

Caltrans, District 6  
Michael Navarro

Caltrans, District 7  
Dianna Watson

Caltrans, District 8  
Dan Kopulsky

Caltrans, District 9  
Gayle Rosander

Caltrans, District 10  
Tom Dumas

Caltrans, District 11  
Jacob Armstrong

Caltrans, District 12  
Marion Regisford

Cal EPA

Air Resources Board

Airport/Energy Projects  
Jim Lerner

Transportation Projects  
Douglas Ito

Industrial Projects  
Mike Tollstrup

State Water Resources Control Board  
Regional Programs Unit  
Division of Financial Assistance

State Water Resources Control Board  
Student Intern, 401 Water Quality Certification Unit  
Division of Water Quality

State Water Resources Control Board  
Phil Crader  
Division of Water Rights

Dept. of Toxic Substances Control  
CEQA Tracking Center

Department of Pesticide Regulation  
CEQA Coordinator

Regional Water Quality Control Board (RWQCB)

RWQCB 1  
Cathleen Hudson  
North Coast Region (1)

RWQCB 2  
Environmental Document Coordinator  
San Francisco Bay Region (2)

RWQCB 3  
Central Coast Region (3)

RWQCB 4  
Teresa Rodgers  
Los Angeles Region (4)

RWQCB 5S  
Central Valley Region (5)

RWQCB 5F  
Central Valley Region (5)  
Fresno Branch Office

RWQCB 5R  
Central Valley Region (5)  
Redding Branch Office

RWQCB 6  
Lahontan Region (6)

RWQCB 6V  
Lahontan Region (6)  
Victorville Branch Office

RWQCB 7  
Colorado River Basin Region (7)

RWQCB 8  
Santa Ana Region (8)

RWQCB 9  
San Diego Region (9)

Other \_\_\_\_\_

\_\_\_\_\_  
\_\_\_\_\_

Conservancy

2000112004

Appendix C

Notice of Completion & Environmental Document Transmittal

Mail to: State Clearinghouse, P. O. Box 3044, Sacramento, CA 95812-3044 (916) 445-0613

For Hand Delivery/Street Address: 1400 Tenth Street, Sacramento, CA 95814

SCH # 2000112004

Project Title: Evergreen Valley College Facilities Master Plan EIR

Lead Agency: San Jose-Evergreen Community College District

Contact Person: Douglas Smith

Mailing Address: 4750 San Felipe Road

Phone: (408) 270-6428

City: San José

Zip: 95135

County: Santa Clara

Project Location:

County: Santa Clara

City/Nearest Community: San Jose

Cross Streets: San Felipe Road and Yerba Buena Road

Zip Code: 95135

Assessor's Parcel No.: 660-21-022

Section:

Twp.:

Range:

Base:

Within 2 Miles: State Hwy #: 101

Waterways:

Airports:

Railways:

Schools:

Document Type:

CEQA:  NOP

Draft EIR

NEPA:  NOI

Other:  Joint Document

Early Cons

Supplement/Subsequent EIR

EA

Final Document

Neg Dec

(Prior SCH No.)

Draft EIS

Other

Mit Neg Dec

Other

CONSL

Local Action Type:

General Plan Update

Specific Plan

Rezone

Annexation

General Plan Amendment

Master Plan

Prezone

Redevelopment

General Plan Element

Planned Unit Development

Use

Coastal Permit

Community Plan

Site Plan

Land Division (Subdivision Use)

Other

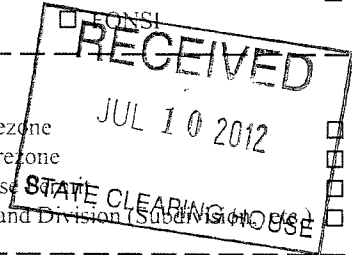

Development Type:

Residential: Units

Acres

Water Facilities: Type

MGD

Office: Sq.ft.

Acres

Employees

Transportation: Type

Commercial: Sq.ft.

Acres

Employees

Mining: Mineral

Industrial: Sq.ft.

Acres

Employees

Power: Type

MW

Educational

Campus Facilities Master Plan

Waste Treatment: Type

MGD

Recreational

Hazardous Waste: Type

Total Acres (approx.)

Other:

Project Issues Discussed in Document:

Aesthetic/Visual

Fiscal

Recreation/Parks

Vegetation

Agricultural Land

Flood Plain/Flooding

Schools/Universities

Water Quality

Air Quality

Forest Land/Fire Hazard

Septic Systems

Water Supply/Groundwater

Archeological/Historical

Geologic/Seismic

Sewer Capacity

Wetland/Riparian

Biological Resources

Minerals

Soil Erosion/Compaction/Grading

Wildlife

Coastal Zone

Noise

Solid Waste

Growth Inducing

Drainage/Absorption

Population/Housing Balance

Toxic/Hazardous

Land Use

Economic/Jobs

Public Services/Facilities

Traffic/Circulation

Cumulative Effects

Other

Present Land Use/Zoning/General Plan Designation:

Community College Campus/Urban land use designation

Project Description: (please use a separate page if necessary)

The 2025 Facilities Master Plan (FMP) involves reorganization of campus facilities and reconfiguration of campus access and circulation. Facility improvements contained in the 2025 FMP include (1) the demolition/removal of existing building on campus; (2) the construction of new buildings on campus; and (3) the renovation of existing buildings on campus to meet the future programs needs as outlined in 2025 Educational Master Plan.

Note: The State Clearinghouse will assign identification numbers for all new projects. If a SCH number already exists for a project (e.g. Notice of Preparation or previous draft document) please fill in.

**DEPARTMENT OF TRANSPORTATION**

111 GRAND AVENUE  
P. O. BOX 23660  
OAKLAND, CA 94623-0660  
PHONE (510) 286-6053  
FAX (510) 286-5559  
TTY 711



*Flex your power!  
Be energy efficient!*

July 13, 2012

SCLVAR038  
SCH#2000112004

Mr. Douglas Smith  
San Jose-Evergreen Community College District  
4750 San Felipe Road  
San Jose, CA 95135

Dear Mr. Smith:

**Evergreen Valley College Facilities—Notice of Preparation**

Thank you for including the California Department of Transportation (Caltrans) in the environmental review process for the project referenced above. As the lead agency, the San Jose-Evergreen Community College District is responsible for all project mitigation, including any needed improvements to State highways. The project's fair share contribution, financing, scheduling, implementation responsibilities and lead agency monitoring should be fully discussed for all proposed mitigation measures. This information should also be presented in the Mitigation Monitoring and Reporting Plan of the environmental document.

***Traffic Impact Study (TIS)***

One of Caltrans' ongoing responsibilities is to collaborate with local agencies to avoid, eliminate, or reduce to insignificance potential adverse impacts by local development on State highways. Therefore, a TIS or a lesser level of analysis may be required to assess the impact of the project on the adjacent transportation network, with specific attention to US 101 if there are traffic impacts, please provide mitigation measures. We recommend using the Caltrans *Guide for the Preparation of Traffic Impact Studies (TIS Guide)* for determining which scenarios and methodologies to use in the analysis. The *TIS Guide* is a starting point for collaboration between the lead agency and Caltrans in determining whether a TIS is needed. The appropriate level of study is determined by the particulars of a project, the prevailing highway conditions, and the forecasted traffic. The *TIS Guide* is available at the following website address:

[http://dot.ca.gov/hq/tpp/offices/ocp/igr\\_ceqa\\_files/tisguide.pdf](http://dot.ca.gov/hq/tpp/offices/ocp/igr_ceqa_files/tisguide.pdf)

The TIS should include:

1. Vicinity map, regional location map, and a site plan clearly showing project access in relation to nearby State roadways. Ingress and egress for all project components should be clearly identified. The State right-of-way (ROW) should be clearly identified. The maps should also include project driveways, local roads and intersections, parking, and transit facilities.
2. Project-related trip generation, distribution, and assignment. The assumptions and

July 13, 2012

Page 2

methodologies used to develop this information should be detailed in the study, and should be supported with appropriate documentation.

3. Average Daily Traffic, AM and PM peak hour volumes and levels of service (LOS) on all roadways where potentially significant impacts may occur, including major road intersections and freeway ramps around the project site, to analyze the traffic impacts on roadways. The analysis should include existing, existing plus project, cumulative and cumulative plus project scenarios. Calculation of cumulative traffic volumes should consider all traffic-generating developments, both existing and future, that would affect study area roadways and intersections. The analysis should clearly identify the project's contribution to area traffic and any degradation to existing and cumulative LOS. The Caltrans LOS threshold, which is the transition between LOS C and D, and is explained in detail in the *TIS Guide*, should be applied to all State facilities.
4. Schematic illustration of traffic conditions including the project site and study area roadways, trip distribution percentages and volumes as well as intersection geometrics, i.e., lane configurations, for the scenarios described above.
5. The project site building potential as identified in the General Plan. The project's consistency with both the Circulation Element of the General Plan and the Congestion Management Agency's Congestion Management Plan should be evaluated.
6. Identification of mitigation for any roadway mainline section or intersection with insufficient capacity to maintain an acceptable LOS with the addition of project-related and/or cumulative traffic. As noted above, the project's fair share contribution, financing, scheduling, implementation responsibilities and lead agency monitoring should also be fully discussed for all proposed mitigation measures.

### ***Vehicle Trip Reduction***

In addition, secondary impacts on pedestrians and bicyclists resulting from any traffic impact mitigation measures should be analyzed. The analysis should describe any pedestrian and bicycle mitigation measures and safety countermeasures that would in turn be needed as a means of maintaining and improving access to transit facilities and reducing vehicle trips and traffic impacts on State highways.

We also encourage you to develop Travel Demand Management (TDM) policies to encourage usage of nearby public transit lines and reduce vehicle trips on the State Highway System. These policies could include lower parking ratios, car-sharing programs, bicycle parking and showers for employees, and providing transit passes to residents and employees, among others. For information about parking ratios, see the Metropolitan Transportation Commission (MTC) report *Reforming Parking Policies to Support Smart Growth* or visit the MTC parking webpage: [http://www.mtc.ca.gov/planning/smart\\_growth/parking/](http://www.mtc.ca.gov/planning/smart_growth/parking/)

Mr. Douglas Smith/ San Jose-Evergreen Community College District

July 13, 2012

Page 3

Should you have any questions regarding this letter, please contact Keith Wayne of my staff by telephone at (510) 286-5737, or by email at [keith\\_wayne@dot.ca.gov](mailto:keith_wayne@dot.ca.gov).

Sincerely,

A handwritten signature in cursive script, appearing to read "Erik Alm".

ERIK ALM, AICP  
District Branch Chief  
Local Development – Intergovernmental Review

c: Scott Morgan, State Clearinghouse



November 19, 2012

San Jose/Evergreen Community College District  
4750 San Felipe Road  
San Jose, CA 95135

Attention: Douglas Smith

Subject: Evergreen Valley College 2025 Facilities Master Plan

Dear Mr. Smith:

Santa Clara Valley Transportation Authority (VTA) staff have reviewed the NOP for expansion of Evergreen Valley College to 14,850 students. We understand the comment period for the NOP closed in August but we appreciate the recent submittal of the NOP to VTA for review. We have the following comments.

Transportation Impact Analysis (TIA) Report

VTA's Congestion Management Program (CMP) requires a Transportation Impact Analysis (TIA) for any project that is expected to generate 100 or more new peak-hour trips. Based on the information provided on the size of this project, a TIA may be required. The updated March 2009 version of the VTA CMP TIA Guidelines should be used when preparing the TIA for this development. This document includes updated procedures for the analysis of bicycle facilities, parking, site circulation and pedestrian access, as well as roadways, and may be downloaded from <http://www.vta.org/news/vtacmp/0 - CMP Technical Guidelines 2012/>. For more information on the TIA Guidelines, please call Shanthi Chatradhi of the VTA Congestion Management Agency Division at 408-952-4224.

Transportation Demand Management

The DEIR and TIA should address potential Transportation Demand Management (TDM) measures in the analysis of Transportation/Traffic impacts. In order to reduce the number of single occupant vehicle trips generated by the project, VTA requests that the Community College District consider a comprehensive transportation demand management (TDM) program in conjunction with the approval of this project.

Effective TDM programs that may be applicable to the College include:

- Parking charges and/or parking cash-out
- Transit fare incentives such as Eco Pass and commuter checks
- Employee carpool matching
- Vanpool program
- Bicycle Lockers and Bicycle Racks
- Showers and Clothes Lockers for bicycle commuters
- On-site or walk-accessible services (day-care, dry-cleaning, fitness, banking, convenience store)
- On-site or accessible restaurants

San Jose / Evergreen Community College District  
November 19, 2012  
Page 2

Transportation Demand Management – Transit Incentives

VTA encourages the District to explore the option of providing VTA Eco Passes or similar discounted transit passes on a continuing basis to students and employees of Evergreen Valley College. The VTA Eco Pass is a photo ID validated with an annual sticker to provide unlimited rides on VTA Bus and Light Rail seven days a week. VTA sells Eco Passes at a discount to residential developments, employers, and educational institutions. We are aware that an Eco Pass program for students is already under consideration at the San José/Evergreen Community College District and encourage the District to include a policy supporting the adoption of transit fare incentives in the Master Plan. For more information about VTA's Eco Pass program, please contact Angela Sipp of VTA at (408) 321-7519.

Thank you for the opportunity to review this project. If you have any questions, please call me at (408) 321-5784.

Sincerely,

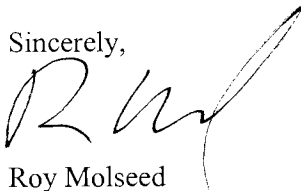

Roy Molseed  
Senior Environmental Planner

cc: Paul Stephenson, Impact Sciences

SJEG1202

**Project Name**  
**On-Site Noise Contours**  
**Existing Conditions**

ROADWAY NAME Segment	Number of Lanes in Each Direction	Median Width	ADT Volume	Design Speed (mph)	Alpha Factor (1)	Vehicle Mix		Distance from Center of Roadway					
						Medium Trucks	Heavy Trucks	CNEL at 75 Feet	DISTANCE TO CONTOUR				
									75 CNEL	70 CNEL	65 CNEL	60 CNEL	
ROADWAY NAME													
S King, west of E Capital Express	2	0	10,160	35	0	1.8%	0.7%	63.0	-	-	-	150	
Silver Creek, Between E Capital Express and YB Road	2	0	14,230	35	0	1.8%	0.7%	64.5	-	-	-	208	
Neiman, North of Aborn	1	0	7,200	25	0	1.8%	0.7%	58.5	-	-	-	-	
Neiman, Between Aborn and YB Road	1	0	7,580	25	0	1.8%	0.7%	58.7	-	-	-	-	
Neiman, South of YB Road	2	0	5,930	35	0	1.8%	0.7%	60.7	-	-	-	88	
San Felipe, north of Aborn	2	0	10,710	35	0	1.8%	0.7%	63.3	-	-	-	158	
San Felipe, between Aborn and YB Ave	2	0	21,600	35	0	1.8%	0.7%	66.3	-	-	101	314	
San Felipe, between YB Ave and Fowler	2	0	18,850	35	0	1.8%	0.7%	65.7	-	-	88	275	
San Felipe, between Fowler and Delta	2	0	18,090	35	0	1.8%	0.7%	65.6	-	-	85	264	
San Felipe, between Delta and Paseo de Arboles	2	0	20,840	35	0	1.8%	0.7%	66.2	-	-	98	304	
San Felipe, between Paseo de Arboles and YB Road	2	0	19,850	35	0	1.8%	0.7%	66.0	-	-	93	289	
San Felipe, south of YB Road	2	0	7,420	35	0	1.8%	0.7%	61.7	-	-	-	110	
Byington, south of YB Road	1	0	280	25	0	1.8%	0.7%	44.4	-	-	-	-	
Aborn, west of E Capitol Express	2	0	8,540	35	0	1.8%	0.7%	62.3	-	-	-	126	
Aborn, between E Capitol Express and Nieman	3	0	30,410	45	0	1.8%	0.7%	70.6	-	85	264	821	
Aborn, between Nieman and San Felipe	3	0	32,020	45	0	1.8%	0.7%	70.8	-	89	278	864	
Aborn, east of San Felipe	3	0	9,920	45	0	1.8%	0.7%	65.7	-	-	88	272	
YB Ave, west of San Felipe	1	0	3,070	25	0	1.8%	0.7%	54.8	-	-	-	-	
Fowler, east of San Felipe	1	0	2,180	25	0	1.8%	0.7%	53.3	-	-	-	-	
Delta, east of San Felipe	1	0	4,340	25	0	1.8%	0.7%	56.3	-	-	-	-	
Paseo de Arboles, east of San Felipe	2	0	6,320	25	0	1.8%	0.7%	58.0	-	-	-	-	
YB Road, west of Silver Creek	2	0	11,900	35	0	1.8%	0.7%	63.7	-	-	-	173	
YB Road, between Silver Creek and Nieman	2	0	22,280	35	0	1.8%	0.7%	66.5	-	-	104	324	
YB Road, between Nieman and Byington	2	0	23,990	35	0	1.8%	0.7%	66.8	-	-	112	349	
YB Road, between Byington and San Felipe	2	0	24,010	35	0	1.8%	0.7%	66.8	-	-	112	349	
YB Road, east of San Felipe	2	0	9,230	35	0	1.8%	0.7%	62.6	-	-	-	136	

Notes:  
(1) Alpha Factor: Coefficient of absorption relating to the effects of the ground surface. An alpha factor of 0 indicates that the site is an acoustically "hard" site, such as asphalt. An alpha factor of 0.5 indicates that the site is an acoustically "soft" site such as heavily vegetated ground cover.  
"-." = contour is located within the roadway lanes or within 75 feet of the roadway centerline.  
Noise levels and distances to contours do not assume any natural or constructed barriers that may attenuate noise.

Assumed 24-Hour Traffic Distribution:	Day	Evening	Night	Total
Total ADT Volumes	77.70%	12.70%	9.60%	100.00%
Medium-Duty Trucks	87.43%	5.05%	7.52%	100.00%
Heavy-Duty Trucks	89.10%	2.84%	8.06%	100.00%

Notes to Modeler: The 24-hour traffic distribution and vehicle mix percentages are defaults. For project-specific numbers, obtain the 24-hour traffic distribution, vehicle mix percentages, and traffic volumes from the traffic engineer. For state and federal highways, obtain this information from the Caltrans website. Column G under Notes: should total 100%. Some jurisdictions have different distributions by roadway type, so check with that jurisdiction. An example is Riverside County.

Impact Statement  
Prepared by:  
Date:

JN:



**Project Name**  
**On-Site Noise Contours**  
**Existing + Project Conditions**

ROADWAY NAME Segment	Number of Lanes in Each Direction	Median Width	ADT Volume	Design Speed (mph)	Alpha Factor (1)	Vehicle Mix		Distance from Center of Roadway				
						Medium Trucks	Heavy Trucks	CNEL at 75 Feet	DISTANCE TO CONTOUR			
									75 CNEL	70 CNEL	65 CNEL	60 CNEL
ROADWAY NAME												
S King, west of E Capital Express	2	0	10,190	35	0	1.8%	0.7%	63.1	-	-	-	150
Silver Creek, Between E Capital Express and YB Road	2	0	14,630	35	0	1.8%	0.7%	64.6	-	-	-	214
Neiman, North of Aborn	1	0	7,320	25	0	1.8%	0.7%	58.6	-	-	-	-
Neiman, Between Aborn and YB Road	1	0	7,720	25	0	1.8%	0.7%	58.8	-	-	-	-
Neiman, South of YB Road	2	0	6,210	35	0	1.8%	0.7%	60.9	-	-	-	92
San Felipe, north of Aborn	2	0	10,840	35	0	1.8%	0.7%	63.3	-	-	-	159
San Felipe, between Aborn and YB Ave	2	0	22,820	35	0	1.8%	0.7%	66.6	-	-	107	332
San Felipe, between YB Ave and Fowler	2	0	20,070	35	0	1.8%	0.7%	66.0	-	-	94	292
San Felipe, between Fowler and Delta	2	0	19,100	35	0	1.8%	0.7%	65.8	-	-	90	279
San Felipe, between Delta and Paseo de Arboles	2	0	21,850	35	0	1.8%	0.7%	66.4	-	-	102	318
San Felipe, between Paseo de Arboles and YB Road	2	0	21,770	35	0	1.8%	0.7%	66.4	-	-	102	317
San Felipe, south of YB Road	2	0	7,560	35	0	1.8%	0.7%	61.8	-	-	-	112
Byington, south of YB Road	1	0	280	25	0	1.8%	0.7%	44.4	-	-	-	-
Aborn, west of E Capitol Express	2	0	8,560	35	0	1.8%	0.7%	62.3	-	-	-	126
Aborn, between E Capitol Express and Nieman	3	0	30,500	45	0	1.8%	0.7%	70.6	-	85	265	824
Aborn, between Nieman and San Felipe	3	0	32,630	45	0	1.8%	0.7%	70.9	-	91	283	880
Aborn, east of San Felipe	3	0	10,000	45	0	1.8%	0.7%	65.7	-	-	88	275
YB Ave, west of San Felipe	1	0	3,070	25	0	1.8%	0.7%	54.8	-	-	-	-
Fowler, east of San Felipe	1	0	2,180	25	0	1.8%	0.7%	53.3	-	-	-	-
Delta, east of San Felipe	1	0	4,340	25	0	1.8%	0.7%	56.3	-	-	-	-
Paseo de Arboles, east of San Felipe	2	0	7,580	25	0	1.8%	0.7%	58.7	-	-	-	-
YB Road, west of Silver Creek	2	0	11,990	35	0	1.8%	0.7%	63.8	-	-	-	176
YB Road, between Silver Creek and Nieman	2	0	23,790	35	0	1.8%	0.7%	66.7	-	-	111	346
YB Road, between Nieman and Byington	2	0	25,700	35	0	1.8%	0.7%	67.1	-	-	120	373
YB Road, between Byington and San Felipe	2	0	26,080	35	0	1.8%	0.7%	67.1	-	-	122	379
YB Road, east of San Felipe	2	0	10,460	35	0	1.8%	0.7%	63.2	-	-	-	154

**Notes:**  
(1) Alpha Factor: Coefficient of absorption relating to the effects of the ground surface. An alpha factor of 0 indicates that the site is an acoustically "hard" site, such as asphalt. An alpha factor of 0.5 indicates that the site is an acoustically "soft" site such as heavily vegetated ground cover.  
"-" = contour is located within the roadway lanes or within 75 feet of the roadway centerline.  
Noise levels and distances to contours do not assume any natural or constructed barriers that may attenuate noise.

Assumed 24-Hour Traffic Distribution:	Day	Evening	Night	Total
Total ADT Volumes	77.70%	12.70%	9.60%	100.00%
Medium-Duty Trucks	87.43%	5.05%	7.52%	100.00%
Heavy-Duty Trucks	89.10%	2.84%	8.06%	100.00%

**Notes to Modeler:** The 24-hour traffic distribution and vehicle mix percentages are defaults. For project-specific numbers, obtain the 24-hour traffic distribution, vehicle mix percentages, and traffic volumes from the traffic engineer. For state and federal highways, obtain this information from the Caltrans website. Column G under Notes: should total 100%. Some jurisdictions have different distributions by roadway type, so check with that jurisdiction. An example is Riverside County.

Project Name  
On-Site Noise Contours  
2025 No Project

ROADWAY NAME Segment	Number of Lanes in Each Direction	Median Width	ADT Volume	Design Speed (mph)	Alpha Factor (1)	Vehicle Mix		Distance from Center of Roadway				
						Medium Trucks	Heavy Trucks	CNEL at 75 Feet	DISTANCE TO CONTOUR			
						75 CNEL	70 CNEL		65 CNEL	60 CNEL		
ROADWAY NAME												
S King, west of E Capital Express	2	0	10,650	35	0	1.8%	0.7%	63.2	-	-	-	157
Silver Creek, Between E Capital Express and YB Road	2	0	15,500	35	0	1.8%	0.7%	64.9	-	-	-	227
Neiman, North of Aborn	1	0	8,450	25	0	1.8%	0.7%	59.2	-	-	-	-
Neiman, Between Aborn and YB Road	1	0	8,100	25	0	1.8%	0.7%	59.0	-	-	-	-
Neiman, South of YB Road	2	0	6,500	35	0	1.8%	0.7%	61.1	-	-	-	96
San Felipe, north of Aborn	2	0	16,500	35	0	1.8%	0.7%	65.2	-	-	78	241
San Felipe, between Aborn and YB Ave	2	0	32,150	35	0	1.8%	0.7%	68.0	-	-	150	465
San Felipe, between YB Ave and Fowler	2	0	29,050	35	0	1.8%	0.7%	67.6	-	-	135	421
San Felipe, between Fowler and Delta	2	0	22,700	35	0	1.8%	0.7%	66.5	-	-	106	330
San Felipe, between Delta and Paseo de Arboles	2	0	24,950	35	0	1.8%	0.7%	66.9	-	-	117	362
San Felipe, between Paseo de Arboles and YB Road	2	0	27,950	35	0	1.8%	0.7%	67.4	-	-	130	405
San Felipe, south of YB Road	2	0	10,150	35	0	1.8%	0.7%	63.0	-	-	-	149
Byington, south of YB Road	1	0	600	25	0	1.8%	0.7%	47.7	-	-	-	-
Aborn, west of E Capitol Express	2	0	8,850	35	0	1.8%	0.7%	62.4	-	-	-	131
Aborn, between E Capitol Express and Nieman	3	0	56,850	45	0	1.8%	0.7%	73.3	-	157	489	1,521
Aborn, between Nieman and San Felipe	3	0	62,100	45	0	1.8%	0.7%	73.7	-	172	534	1,659
Aborn, east of San Felipe	3	0	21,850	45	0	1.8%	0.7%	69.1	-	-	191	593
YB Ave, west of San Felipe	1	0	3,250	25	0	1.8%	0.7%	55.1	-	-	-	-
Fowler, east of San Felipe	1	0	3,200	25	0	1.8%	0.7%	55.0	-	-	-	-
Delta, east of San Felipe	1	0	5,030	25	0	1.8%	0.7%	57.0	-	-	-	-
Paseo de Arboles, east of San Felipe	2	0	6,300	25	0	1.8%	0.7%	57.9	-	-	-	-
YB Road, west of Silver Creek	2	0	22,500	35	0	1.8%	0.7%	66.5	-	-	105	327
YB Road, between Silver Creek and Nieman	2	0	43,550	35	0	1.8%	0.7%	69.4	-	-	202	627
YB Road, between Nieman and Byington	2	0	42,200	35	0	1.8%	0.7%	69.2	-	-	196	608
YB Road, between Byington and San Felipe	2	0	47,100	35	0	1.8%	0.7%	69.7	-	-	218	678
YB Road, east of San Felipe	2	0	17,850	35	0	1.8%	0.7%	65.5	-	-	84	261

**Notes:**

(1) Alpha Factor: Coefficient of absorption relating to the effects of the ground surface. An alpha factor of 0 indicates that the site is an acoustically "hard" site, such as asphalt. An alpha factor of 0.5 indicates that the site is an acoustically "soft" site such as heavily vegetated ground cover.

"-" = contour is located within the roadway lanes or within 75 feet of the roadway centerline.

Noise levels and distances to contours do not assume any natural or constructed barriers that may attenuate noise.

**Assumed 24-Hour Traffic Distribution:**

	Day	Evening	Night	Total
Total ADT Volumes	77.70%	12.70%	9.60%	100.00%
Medium-Duty Trucks	87.43%	5.05%	7.52%	100.00%
Heavy-Duty Trucks	89.10%	2.84%	8.06%	100.00%

Notes to Modeler: The 24-hour traffic distribution and vehicle mix percentages are defaults. For project-specific numbers, obtain the 24-hour traffic distribution, vehicle mix percentages, and traffic volumes from the traffic engineer. For state and federal highways, obtain this information from the Caltrans website. Column G under Notes: should total 100%. Some jurisdictions have different distributions by roadway type, so check with that jurisdiction. An example is Riverside County.

**Project Name**  
**On-Site Noise Contours**  
**2025 + Project Conditions**

ROADWAY NAME Segment	Number of Lanes in Each Direction	Median Width	ADT Volume	Design Speed (mph)	Alpha Factor (1)	Vehicle Mix		Distance from Center of Roadway					
						Medium Trucks	Heavy Trucks	CNEL at 75 Feet	DISTANCE TO CONTOUR				
									75 CNEL	70 CNEL	65 CNEL	60 CNEL	
ROADWAY NAME													
S King, west of E Capital Express	2	0	10,680	35	0	1.8%	0.7%	63.3	-	-	-	157	
Silver Creek, Between E Capital Express and YB Road	2	0	15,900	35	0	1.8%	0.7%	65.0	-	-	-	233	
Neiman, North of Aborn	1	0	8,570	25	0	1.8%	0.7%	59.3	-	-	-	-	
Neiman, Between Aborn and YB Road	1	0	8,240	25	0	1.8%	0.7%	59.1	-	-	-	-	
Neiman, South of YB Road	2	0	6,630	35	0	1.8%	0.7%	61.2	-	-	-	98	
San Felipe, north of Aborn	2	0	16,630	35	0	1.8%	0.7%	65.2	-	-	78	243	
San Felipe, between Aborn and YB Ave	2	0	33,370	35	0	1.8%	0.7%	68.2	-	-	155	483	
San Felipe, between YB Ave and Fowler	2	0	30,270	35	0	1.8%	0.7%	67.8	-	-	141	438	
San Felipe, between Fowler and Delta	2	0	23,710	35	0	1.8%	0.7%	66.7	-	-	111	345	
San Felipe, between Delta and Paseo de Arboles	2	0	25,960	35	0	1.8%	0.7%	67.1	-	-	121	377	
San Felipe, between Paseo de Arboles and YB Road	2	0	29,870	35	0	1.8%	0.7%	67.7	-	-	139	433	
San Felipe, south of YB Road	2	0	10,290	35	0	1.8%	0.7%	63.1	-	-	-	152	
Byington, south of YB Road	1	0	600	25	0	1.8%	0.7%	47.7	-	-	-	-	
Aborn, west of E Capitol Express	2	0	8,870	35	0	1.8%	0.7%	62.5	-	-	-	131	
Aborn, between E Capitol Express and Nieman	3	0	56,940	45	0	1.8%	0.7%	73.3	-	158	490	1,523	
Aborn, between Nieman and San Felipe	3	0	62,710	45	0	1.8%	0.7%	73.7	-	173	539	1,675	
Aborn, east of San Felipe	3	0	21,930	45	0	1.8%	0.7%	69.1	-	-	192	595	
YB Ave, west of San Felipe	1	0	3,250	25	0	1.8%	0.7%	55.1	-	-	-	-	
Fowler, east of San Felipe	1	0	3,200	25	0	1.8%	0.7%	55.0	-	-	-	-	
Delta, east of San Felipe	1	0	5,030	25	0	1.8%	0.7%	57.0	-	-	-	-	
Paseo de Arboles, east of San Felipe	2	0	7,560	25	0	1.8%	0.7%	58.7	-	-	-	-	
YB Road, west of Silver Creek	2	0	22,440	35	0	1.8%	0.7%	66.5	-	-	105	326	
YB Road, between Silver Creek and Nieman	2	0	45,060	35	0	1.8%	0.7%	69.5	-	-	209	649	
YB Road, between Nieman and Byington	2	0	43,910	35	0	1.8%	0.7%	69.4	-	-	204	632	
YB Road, between Byington and San Felipe	2	0	49,170	35	0	1.8%	0.7%	69.9	-	-	227	707	
YB Road, east of San Felipe	2	0	19,080	35	0	1.8%	0.7%	65.8	-	-	90	278	

Notes:  
(1) Alpha Factor: Coefficient of absorption relating to the effects of the ground surface. An alpha factor of 0 indicates that the site is an acoustically "hard" site, such as asphalt. An alpha factor of 0.5 indicates that the site is an acoustically "soft" site such as heavily vegetated ground cover.  
"- " = contour is located within the roadway lanes or within 75 feet of the roadway centerline.  
Noise levels and distances to contours do not assume any natural or constructed barriers that may attenuate noise.

Assumed 24-Hour Traffic Distribution:	Day	Evening	Night	Total
Total ADT Volumes	77.70%	12.70%	9.60%	100.00%
Medium-Duty Trucks	87.43%	5.05%	7.52%	100.00%
Heavy-Duty Trucks	89.10%	2.84%	8.06%	100.00%

Notes to Modeler: The 24-hour traffic distribution and vehicle mix percentages are defaults. For project-specific numbers, obtain the 24-hour traffic distribution, vehicle mix percentages, and traffic volumes from the traffic engineer. For state and federal highways, obtain this information from the Caltrans website. Column G under Notes: should total 100%. Some jurisdictions have different distributions by roadway type, so check with that jurisdiction. An example is Riverside County.

**APPENDIX 4.2**

---

**Air Quality Modeling Output**

Urbemis 2007 Version 9.2.4

Summary Report for Summer Emissions (Pounds/Day)

File Name: Z:\EBell\San Jose Colleges\Modeling\EVC Construction.urb924

Project Name: SJCC Construction

Project Location: Bay Area Air District

On-Road Vehicle Emissions Based on: Version : Emfac2007 V2.3 Nov 1 2006

Off-Road Vehicle Emissions Based on: OFFROAD2007

CONSTRUCTION EMISSION ESTIMATES

	<u>ROG</u>	<u>NOx</u>	<u>CO</u>	<u>SO2</u>	<u>PM10 Dust</u>	<u>PM10 Exhaust</u>	<u>PM10</u>	<u>PM2.5 Dust</u>	<u>PM2.5 Exhaust</u>	<u>PM2.5</u>
2019 TOTALS (lbs/day unmitigated)	13.90	17.17	17.16	0.01	5.85	0.90	6.62	1.22	0.83	1.93
2019 TOTALS (lbs/day mitigated)	13.90	17.17	17.16	0.01	4.31	0.90	5.08	0.90	0.83	1.61

Page: 1

1/18/2013 1:46:47 PM

Urbemis 2007 Version 9.2.4

Summary Report for Winter Emissions (Pounds/Day)

File Name: Z:\EBell\San Jose Colleges\Modeling\EVC Construction.urb924

Project Name: EVC Construction

Project Location: Bay Area Air District

On-Road Vehicle Emissions Based on: Version : Emfac2007 V2.3 Nov 1 2006

Off-Road Vehicle Emissions Based on: OFFROAD2007

CONSTRUCTION EMISSION ESTIMATES

	<u>ROG</u>	<u>NOx</u>	<u>CO</u>	<u>SO2</u>	<u>PM10 Dust</u>	<u>PM10 Exhaust</u>	<u>PM10</u>	<u>PM2.5 Dust</u>	<u>PM2.5 Exhaust</u>	<u>PM2.5</u>
2019 TOTALS (lbs/day unmitigated)	13.90	17.17	17.16	0.01	5.85	0.90	6.62	1.22	0.83	1.93
2019 TOTALS (lbs/day mitigated)	13.90	17.17	17.16	0.01	4.31	0.90	5.08	0.90	0.83	1.61

Urbemis 2007 Version 9.2.4

Summary Report for Annual Emissions (Tons/Year)

File Name: Z:\EBell\San Jose Colleges\Modeling\EVC Construction.urb924

Project Name: EVC Construction

Project Location: Bay Area Air District

On-Road Vehicle Emissions Based on: Version : Emfac2007 V2.3 Nov 1 2006

Off-Road Vehicle Emissions Based on: OFFROAD2007

CONSTRUCTION EMISSION ESTIMATES

	<u>ROG</u>	<u>NOx</u>	<u>CO</u>	<u>SO2</u>	<u>PM10 Dust</u>	<u>PM10 Exhaust</u>	<u>PM10</u>	<u>PM2.5 Dust</u>	<u>PM2.5 Exhaust</u>	<u>PM2.5</u>	<u>CO2</u>
2019 TOTALS (tons/year unmitigated)	0.35	1.33	1.38	0.00	0.39	0.06	0.46	0.08	0.06	0.14	308.61
2019 TOTALS (tons/year mitigated)	0.35	1.33	1.38	0.00	0.37	0.06	0.43	0.08	0.06	0.14	308.61
Percent Reduction	0.00	0.00	0.00	0.00	5.70	0.00	4.91	5.70	0.00	3.33	0.00

Urbemis 2007 Version 9.2.4

Summary Report for Summer Emissions (Pounds/Day)

File Name:

Project Name: EVC Existing

Project Location: Santa Clara County

On-Road Vehicle Emissions Based on: Version : Emfac2007 V2.3 Nov 1 2006

Off-Road Vehicle Emissions Based on: OFFROAD2007

AREA SOURCE EMISSION ESTIMATES

	<u>ROG</u>	<u>NOx</u>	<u>CO</u>	<u>SO2</u>	<u>PM10</u>	<u>PM2.5</u>
TOTALS (lbs/day, unmitigated)	2.38	3.35	4.35	0.00	0.02	0.02

OPERATIONAL (VEHICLE) EMISSION ESTIMATES

	<u>ROG</u>	<u>NOx</u>	<u>CO</u>	<u>SO2</u>	<u>PM10</u>	<u>PM2.5</u>
TOTALS (lbs/day, unmitigated)	80.40	98.59	1,082.28	1.17	213.35	40.43

SUM OF AREA SOURCE AND OPERATIONAL EMISSION ESTIMATES

	<u>ROG</u>	<u>NOx</u>	<u>CO</u>	<u>SO2</u>	<u>PM10</u>	<u>PM2.5</u>
TOTALS (lbs/day, unmitigated)	82.78	101.94	1,086.63	1.17	213.37	40.45



Summary Report for Winter Emissions (Pounds/Day)

File Name:

Project Name: EVC Existing

Project Location: Santa Clara County

On-Road Vehicle Emissions Based on: Version : Emfac2007 V2.3 Nov 1 2006

Off-Road Vehicle Emissions Based on: OFFROAD2007

AREA SOURCE EMISSION ESTIMATES

	<u>ROG</u>	<u>NOx</u>	<u>CO</u>	<u>SO2</u>	<u>PM10</u>	<u>PM2.5</u>
TOTALS (lbs/day, unmitigated)	2.26	3.33	2.80	0.00	0.01	0.01

OPERATIONAL (VEHICLE) EMISSION ESTIMATES

	<u>ROG</u>	<u>NOx</u>	<u>CO</u>	<u>SO2</u>	<u>PM10</u>	<u>PM2.5</u>
TOTALS (lbs/day, unmitigated)	97.19	149.47	1,158.60	1.01	213.35	40.43

SUM OF AREA SOURCE AND OPERATIONAL EMISSION ESTIMATES

	<u>ROG</u>	<u>NOx</u>	<u>CO</u>	<u>SO2</u>	<u>PM10</u>	<u>PM2.5</u>
TOTALS (lbs/day, unmitigated)	99.45	152.80	1,161.40	1.01	213.36	40.44

Urbemis 2007 Version 9.2.4

Summary Report for Summer Emissions (Pounds/Day)

File Name:

Project Name: EVC Proposed

Project Location: Santa Clara County

On-Road Vehicle Emissions Based on: Version : Emfac2007 V2.3 Nov 1 2006

Off-Road Vehicle Emissions Based on: OFFROAD2007

AREA SOURCE EMISSION ESTIMATES

	<u>ROG</u>	<u>NOx</u>	<u>CO</u>	<u>SO2</u>	<u>PM10</u>	<u>PM2.5</u>
TOTALS (lbs/day, unmitigated)	2.45	3.45	4.43	0.00	0.02	0.02

OPERATIONAL (VEHICLE) EMISSION ESTIMATES

	<u>ROG</u>	<u>NOx</u>	<u>CO</u>	<u>SO2</u>	<u>PM10</u>	<u>PM2.5</u>
TOTALS (lbs/day, unmitigated)	98.90	122.12	1,340.59	1.45	264.27	50.08

SUM OF AREA SOURCE AND OPERATIONAL EMISSION ESTIMATES

	<u>ROG</u>	<u>NOx</u>	<u>CO</u>	<u>SO2</u>	<u>PM10</u>	<u>PM2.5</u>
TOTALS (lbs/day, unmitigated)	101.35	125.57	1,345.02	1.45	264.29	50.10

Summary Report for Winter Emissions (Pounds/Day)

File Name:

Project Name: EVC Proposed

Project Location: Santa Clara County

On-Road Vehicle Emissions Based on: Version : Emfac2007 V2.3 Nov 1 2006

Off-Road Vehicle Emissions Based on: OFFROAD2007

AREA SOURCE EMISSION ESTIMATES

	<u>ROG</u>	<u>NOx</u>	<u>CO</u>	<u>SO2</u>	<u>PM10</u>	<u>PM2.5</u>
TOTALS (lbs/day, unmitigated)	2.33	3.43	2.88	0.00	0.01	0.01

OPERATIONAL (VEHICLE) EMISSION ESTIMATES

	<u>ROG</u>	<u>NOx</u>	<u>CO</u>	<u>SO2</u>	<u>PM10</u>	<u>PM2.5</u>
TOTALS (lbs/day, unmitigated)	120.38	185.14	1,435.13	1.25	264.27	50.08

SUM OF AREA SOURCE AND OPERATIONAL EMISSION ESTIMATES

	<u>ROG</u>	<u>NOx</u>	<u>CO</u>	<u>SO2</u>	<u>PM10</u>	<u>PM2.5</u>
TOTALS (lbs/day, unmitigated)	122.71	188.57	1,438.01	1.25	264.28	50.09

**EVC Campus  
Stationary Source Emissions  
Natural Gas Boilers**

Boiler Data

Nominal Rating per Boiler: 8.3 MMBtu/hr  
 Number of Boilers: 3  
 Operational hours: 24 hr/day  
 8,760 hr/yr  
 Capacity Factor: 75%  
 Standard Temp 60 deg F  
 Molar Volume 379.70 scf/mole  
 Heat Content of Natural Gas 1,020 Btu/scf

**Table STA-1  
Natural Gas Boiler Emissions**

Units	Criteria Pollutants						Greenhouse Gases			
	ROG	NO <sub>x</sub>	CO	SO <sub>x</sub>	PM10	PM2.5	CO <sub>2</sub>	CH <sub>4</sub>	N <sub>2</sub> O	CO <sub>2</sub> e
ppm @ 3% O <sub>2</sub>		30.00								
lbs/MMBtu	0.0054	0.0360	0.0824	0.0006	0.0075	0.0075	116.98	0.0110	0.0002	117.28
lbs/hr	0.10	0.67	1.54	0.01	0.14	0.14	2,184.55	0.21	0.00	2,190.15
lbs/day	1.81	12.10	27.68	0.20	2.50	2.50	39,321.91	3.71	0.07	4,906.07
lbs/yr	661.59	4,417.01	10,104.27	72.17	914.20	914.20	14,352,496.72	1,352.48	27.05	14,389,284.13
tons/yr	0.33	2.21	5.05	0.04	0.46	0.46	7,176.25	0.68	0.01	7,194.64
metric tons/yr							6,510.18	0.61	0.01	6,526.87

Notes:

1. Emission factors for ROG, CO, PM10, and SO<sub>x</sub>: U.S. Environmental Protection Agency, *AP-42 Compilation of Air Pollutant Emission Factors*, Chapter 1.4, Table 1.4-1 and 1.4-2.
2. Emission factor for NO<sub>x</sub> assumes compliance with 30 ppm standard.
3. Emission factor for PM2.5 assumes all PM is less than 1 micron in diameter.
4. Emission factors for CO<sub>2</sub>, CH<sub>4</sub>, and N<sub>2</sub>O: California Climate Action Registry, *General Reporting Protocol*, Version 3.1, (2009) 101, 103.
5. Emissions of CO<sub>2</sub>e assumes the following global warming potentials: CO<sub>2</sub> = 1, CH<sub>4</sub> = 21, N<sub>2</sub>O = 310.

**EVC Campus  
Stationary Source Emissions  
Emergency Generator**

Generator Data

Nominal Rating of Generator: 25 kW  
 Number of New Generators: 10  
 Engine size 34 hp  
 Operational hours: 1 hr/day  
 50 hr/yr  
 Capacity Factor: 100%  
 MMBtu/yr 42.65

**Table STA-2  
Emergency Generator Emissions**

Units	Criteria Pollutants						Greenhouse Gases			
	ROG	NO <sub>x</sub>	CO	SO <sub>x</sub>	PM10	PM2.5	CO <sub>2</sub>	CH <sub>4</sub>	N <sub>2</sub> O	CO <sub>2</sub> e
lbs/hp-hr	2.47E-03	3.10E-02	6.68E-03	1.21E-05	2.20E-03	2.20E-03				
lbs/hr	0.84	10.54	2.27	0.00	0.75	0.75				
lbs/day	0.12	1.44	0.31	0.00	0.10	0.10				
lbs/yr	41.99	527.00	113.56	0.21	37.40	37.40				
tons/yr	0.02	0.26	0.06	0.00	0.02	0.02				
kg/MMBtu							19.95	1.10E-02	6.00E-04	20.37
metric tons/yr							0.85	4.69E-04	2.56E-05	0.87

Notes:

1. Emission factors for ROG, NO<sub>x</sub>, CO, PM10, and SO<sub>x</sub>: U.S. Environmental Protection Agency, *AP-42 Compilation of Air Pollutant Emission Factors*, Chapter 3.3, Table 3.3-1. Emission Factor for SO<sub>x</sub> is based on 15 ppm (0.0015%).
2. Emission factors for SO<sub>x</sub>: U.S. Environmental Protection Agency, *AP-42 Compilation of Air Pollutant Emission Factors*, Chapter 3.4, Table 3.4-1. Emission Factor for SO<sub>x</sub> is based on 15 ppm (0.0015%).
3. Emission factor for PM2.5 assumes all PM is less than 1 micron in diameter.
4. Emission factors for CO<sub>2</sub>, CH<sub>4</sub>, and N<sub>2</sub>O: California Climate Action Registry, *General Reporting Protocol*, Version 3.1, (2009) 101, 103.
5. Emissions of CO<sub>2</sub>e assumes the following global warming potentials: CO<sub>2</sub> = 1, CH<sub>4</sub> = 21, N<sub>2</sub>O = 310.

**BAY AREA AQMD SIMPLIFIED CALINE4 ANALYSIS; UPDATED WITH EMFAC2007**

Project Title: Evergreen College FMP  
 Intersection: 101 SB and Yerba Buena Rd  
 Analysis Condition: Cumulative plus Project  
 Nearest Air Monitoring Station measuring CO: Jackson St San Jose  
 Background 1-hour CO Concentration (ppm): 6.2  
 Background 8-hour CO Concentration (ppm): 4.3  
 Persistence Factor: 0.6  
 Analysis Year: 2020

Roadway Type	No. of Lanes	Approach/Departure Speed	
		A.M.	P.M.
North-South Roadway: 101 SB Off-Ramp	2	5	5
East-West Roadway: Yerba Buena Road	2	5	5

**EMFAC2007 COMPOSITE EMISSION FACTORS FOR CO**

Air Basin: SF Bay Area County: Santa Clara  
 Assumes lowest mean wintertime temperature of 49 degrees F and 71% humidity.

Year	Average Speed (miles per hour)									
	5	8	11	14	17	20	23	26	29	32
2010	6.419	5.647	5.034	4.542	4.142	3.818	3.553	3.333	3.15	3
2011	5.798	5.116	4.572	4.134	3.777	3.487	3.249	3.051	2.886	2.749
2012	5.251	4.645	4.161	3.77	3.451	3.19	2.976	2.797	2.647	2.522
2013	4.757	4.22	3.79	3.44	3.154	2.92	2.728	2.566	2.43	2.316
2014	4.323	3.844	3.46	3.146	2.889	2.679	2.505	2.359	2.235	2.13
2015	3.937	3.51	3.165	2.883	2.651	2.461	2.305	2.172	2.059	1.963
2020	2.646	2.387	2.174	1.997	1.85	1.728	1.627	1.539	1.464	1.398
2025	1.949	1.77	1.621	1.496	1.392	1.306	1.233	1.17	1.115	1.067
2030	1.615	1.471	1.35	1.248	1.163	1.093	1.034	0.983	0.937	0.898
2035	1.403	1.276	1.17	1.081	1.007	0.946	0.896	0.852	0.813	0.779
2040	1.283	1.164	1.065	0.982	0.913	0.858	0.813	0.773	0.738	0.706

**PEAK HOUR TURNING VOLUMES**

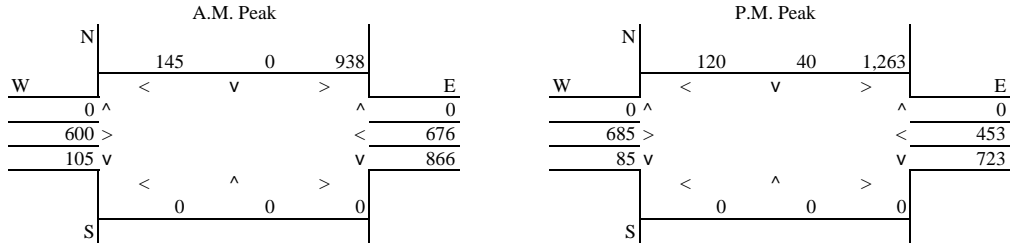

**Representative Traffic Volumes (Vehicles per Hour)**

N-S Road	1,083	N-S Road	1,423
E-W Road	3,080	E-W Road	3,124
Primary Road = E-W Road		Primary Road = E-W Road	

**ROADWAY CO CONTRIBUTIONS**

Roadway	Reference CO Concentrations			*	Traffic Volume	*	Emission Factor	÷	
	0 Feet	25 Feet	50 Feet						
<b>A.M. Peak Hour</b>									
N-S Road	3.7	2.7	2.2	*	1,083	*	2.65	÷	100,000
E-W Road	14.0	7.6	5.7	*	3,080	*	2.65	÷	100,000
<b>P.M. Peak Hour</b>									
N-S Road	3.7	2.7	2.2	*	1,423	*	2.65	÷	100,000
E-W Road	14.0	7.6	5.7	*	3,124	*	2.65	÷	100,000

**TOTAL CO CONCENTRATIONS (ppm)**

	A.M. Peak Hour	P.M. Peak Hour	8-Hour
0 Feet from Roadway Edge	7.4	7.5	5.1
25 Feet from Roadway Edge	6.9	6.9	4.7
50 Feet from Roadway Edge	6.7	6.8	4.6

**BAY AREA AQMD SIMPLIFIED CALINE4 ANALYSIS; UPDATED WITH EMFAC2007**

Project Title: Evergreen College FMP  
 Intersection: Capitol Expressway and Aborn Rd  
 Analysis Condition: Cumulative plus Project  
 Nearest Air Monitoring Station measuring CO: Jackson St San Jose  
 Background 1-hour CO Concentration (ppm): 6.2  
 Background 8-hour CO Concentration (ppm): 4.3  
 Persistence Factor: 0.6  
 Analysis Year: 2020

	Roadway Type	No. of Lanes	Approach/Departure Speed	
			A.M.	P.M.
North-South Roadway: Capitol Expressway	AT GRADE	8	5	5
East-West Roadway: Aborn Road	AT GRADE	4	5	5

**EMFAC2007 COMPOSITE EMISSION FACTORS FOR CO**

Air Basin: SF Bay Area County: Santa Clara  
 Assumes lowest mean wintertime temperature of 49 degrees F and 71% humidity.

Year	Average Speed (miles per hour)									
	5	8	11	14	17	20	23	26	29	32
2010	6.419	5.647	5.034	4.542	4.142	3.818	3.553	3.333	3.15	3
2011	5.798	5.116	4.572	4.134	3.777	3.487	3.249	3.051	2.886	2.749
2012	5.251	4.645	4.161	3.77	3.451	3.19	2.976	2.797	2.647	2.522
2013	4.757	4.22	3.79	3.44	3.154	2.92	2.728	2.566	2.43	2.316
2014	4.323	3.844	3.46	3.146	2.889	2.679	2.505	2.359	2.235	2.13
2015	3.937	3.51	3.165	2.883	2.651	2.461	2.305	2.172	2.059	1.963
2020	2.646	2.387	2.174	1.997	1.85	1.728	1.627	1.539	1.464	1.398
2025	1.949	1.77	1.621	1.496	1.392	1.306	1.233	1.17	1.115	1.067
2030	1.615	1.471	1.35	1.248	1.163	1.093	1.034	0.983	0.937	0.898
2035	1.403	1.276	1.17	1.081	1.007	0.946	0.896	0.852	0.813	0.779
2040	1.283	1.164	1.065	0.982	0.913	0.858	0.813	0.773	0.738	0.706

**PEAK HOUR TURNING VOLUMES**

A.M. Peak				P.M. Peak			
N	45	1,210	900	N	100	1,760	960
W	<	v	>	W	<	v	>
E	120 ^		670	E	260 ^		920
	216 >		662		456 >		528
S	130 v		1,500	S	165 v		1,295
	<	^	>		<	^	>
	180	1,675	1,255		205	1,565	1,555

**Representative Traffic Volumes (Vehicles per Hour)**

N-S Road	5,950	N-S Road	6,545
E-W Road	5,203	E-W Road	5,714
Primary Road =	N-S Road	Primary Road =	N-S Road

**ROADWAY CO CONTRIBUTIONS**

Roadway	Reference CO Concentrations			Traffic Volume	Emission Factor
	0 Feet	25 Feet	50 Feet		
<b>A.M. Peak Hour</b>					
N-S Road	8.5	5.7	4.6	* 5,950	* 2.65 ÷ 100,000
E-W Road	3.3	2.6	2.2	* 5,203	* 2.65 ÷ 100,000
<b>P.M. Peak Hour</b>					
N-S Road	8.5	5.7	4.6	* 6,545	* 2.65 ÷ 100,000
E-W Road	3.3	2.6	2.2	* 5,714	* 2.65 ÷ 100,000

**TOTAL CO CONCENTRATIONS (ppm)**

	A.M. Peak Hour	P.M. Peak Hour	8-Hour
0 Feet from Roadway Edge	8.0	8.2	5.5
25 Feet from Roadway Edge	7.5	7.6	5.1
50 Feet from Roadway Edge	7.2	7.3	5.0

**BAY AREA AQMD SIMPLIFIED CALINE4 ANALYSIS; UPDATED WITH EMFAC2007**

Project Title: Evergreen College FMP  
 Intersection: San Felipe Road and Aborn Rd  
 Analysis Condition: Cumulative plus Project  
 Nearest Air Monitoring Station measuring CO: Jackson St San Jose  
 Background 1-hour CO Concentration (ppm): 6.2  
 Background 8-hour CO Concentration (ppm): 4.3  
 Persistence Factor: 0.6  
 Analysis Year: 2020

Roadway Type	No. of Lanes	Approach/Departure Speed		
		A.M.	P.M.	
North-South Roadway: San Felipe Road	AT GRADE	4	5	5
East-West Roadway: Aborn Road	AT GRADE	6	5	5

**EMFAC2007 COMPOSITE EMISSION FACTORS FOR CO**

Air Basin: SF Bay Area County: Santa Clara  
 Assumes lowest mean wintertime temperature of 49 degrees F and 71% humidity.

Year	Average Speed (miles per hour)									
	5	8	11	14	17	20	23	26	29	32
2010	6.419	5.647	5.034	4.542	4.142	3.818	3.553	3.333	3.15	3
2011	5.798	5.116	4.572	4.134	3.777	3.487	3.249	3.051	2.886	2.749
2012	5.251	4.645	4.161	3.77	3.451	3.19	2.976	2.797	2.647	2.522
2013	4.757	4.22	3.79	3.44	3.154	2.92	2.728	2.566	2.43	2.316
2014	4.323	3.844	3.46	3.146	2.889	2.679	2.505	2.359	2.235	2.13
2015	3.937	3.51	3.165	2.883	2.651	2.461	2.305	2.172	2.059	1.963
2020	2.646	2.387	2.174	1.997	1.85	1.728	1.627	1.539	1.464	1.398
2025	1.949	1.77	1.621	1.496	1.392	1.306	1.233	1.17	1.115	1.067
2030	1.615	1.471	1.35	1.248	1.163	1.093	1.034	0.983	0.937	0.898
2035	1.403	1.276	1.17	1.081	1.007	0.946	0.896	0.852	0.813	0.779
2040	1.283	1.164	1.065	0.982	0.913	0.858	0.813	0.773	0.738	0.706

**PEAK HOUR TURNING VOLUMES**

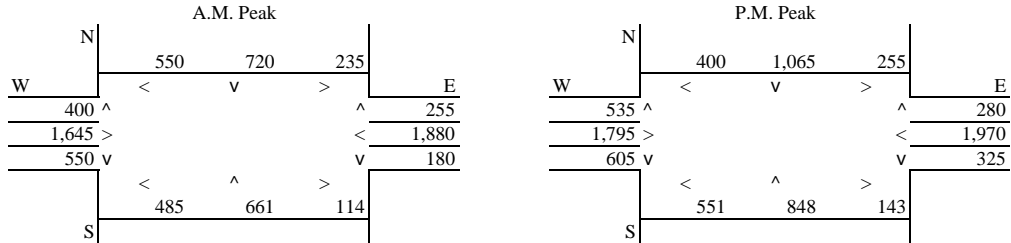

**Representative Traffic Volumes (Vehicles per Hour)**

N-S Road	2,821	N-S Road	3,537
E-W Road	5,510	E-W Road	5,856
Primary Road = E-W Road		Primary Road = E-W Road	

**ROADWAY CO CONTRIBUTIONS**

Roadway	Reference CO Concentrations			*	Traffic Volume	*	Emission		
	0 Feet	25 Feet	50 Feet				Factor		
<b>A.M. Peak Hour</b>									
N-S Road	3.3	2.6	2.2	*	2,821	*	2.65	÷	100,000
E-W Road	9.5	6.1	4.9	*	5,510	*	2.65	÷	100,000
<b>P.M. Peak Hour</b>									
N-S Road	3.3	2.6	2.2	*	3,537	*	2.65	÷	100,000
E-W Road	9.5	6.1	4.9	*	5,856	*	2.65	÷	100,000

**TOTAL CO CONCENTRATIONS (ppm)**

	A.M. Peak Hour	P.M. Peak Hour	8-Hour
0 Feet from Roadway Edge	7.8	8.0	5.4
25 Feet from Roadway Edge	7.3	7.4	5.0
50 Feet from Roadway Edge	7.1	7.2	4.9



**BAY AREA AQMD SIMPLIFIED CALINE4 ANALYSIS; UPDATED WITH EMFAC2007**

Project Title: Evergreen College FMP  
 Intersection: San Felipe Road and Yerba Buena Rd  
 Analysis Condition: Cumulative plus Project  
 Nearest Air Monitoring Station measuring CO: Jackson St San Jose  
 Background 1-hour CO Concentration (ppm): 6.2  
 Background 8-hour CO Concentration (ppm): 4.3  
 Persistence Factor: 0.6  
 Analysis Year: 2020

	Roadway Type	No. of Lanes	Approach/Departure Speed	
			A.M.	P.M.
North-South Roadway: San Felipe Road	AT GRADE	4	5	5
East-West Roadway: Yerba Buena Road	AT GRADE	4	5	5

**EMFAC2007 COMPOSITE EMISSION FACTORS FOR CO**

Air Basin: SF Bay Area County: Santa Clara  
 Assumes lowest mean wintertime temperature of 49 degrees F and 71% humidity.

Year	Average Speed (miles per hour)									
	5	8	11	14	17	20	23	26	29	32
2010	6.419	5.647	5.034	4.542	4.142	3.818	3.553	3.333	3.15	3
2011	5.798	5.116	4.572	4.134	3.777	3.487	3.249	3.051	2.886	2.749
2012	5.251	4.645	4.161	3.77	3.451	3.19	2.976	2.797	2.647	2.522
2013	4.757	4.22	3.79	3.44	3.154	2.92	2.728	2.566	2.43	2.316
2014	4.323	3.844	3.46	3.146	2.889	2.679	2.505	2.359	2.235	2.13
2015	3.937	3.51	3.165	2.883	2.651	2.461	2.305	2.172	2.059	1.963
2020	2.646	2.387	2.174	1.997	1.85	1.728	1.627	1.539	1.464	1.398
2025	1.949	1.77	1.621	1.496	1.392	1.306	1.233	1.17	1.115	1.067
2030	1.615	1.471	1.35	1.248	1.163	1.093	1.034	0.983	0.937	0.898
2035	1.403	1.276	1.17	1.081	1.007	0.946	0.896	0.852	0.813	0.779
2040	1.283	1.164	1.065	0.982	0.913	0.858	0.813	0.773	0.738	0.706

**PEAK HOUR TURNING VOLUMES**

A.M. Peak				P.M. Peak			
N	562	258	352	N	556	462	343
W	<	v	>	W	<	v	>
E	698 ^		115	E	663 ^		341
	1,428 >		1,207		1,613 >		1,441
S	150 v		98	S	350 v		217
	<	^	>		<	^	>
	305	473	128		215	438	168

**Representative Traffic Volumes (Vehicles per Hour)**

N-S Road	2,458	N-S Road	2,803
E-W Road	4,350	E-W Road	4,838
Primary Road = E-W Road		Primary Road = E-W Road	

**ROADWAY CO CONTRIBUTIONS**

Roadway	Reference CO Concentrations			Traffic Volume	Emission Factor
	0 Feet	25 Feet	50 Feet		
<b>A.M. Peak Hour</b>					
N-S Road	3.3	2.6	2.2	* 2,458	* 2.65 ÷ 100,000
E-W Road	11.9	7.0	5.4	* 4,350	* 2.65 ÷ 100,000
<b>P.M. Peak Hour</b>					
N-S Road	3.3	2.6	2.2	* 2,803	* 2.65 ÷ 100,000
E-W Road	11.9	7.0	5.4	* 4,838	* 2.65 ÷ 100,000

**TOTAL CO CONCENTRATIONS (ppm)**

	A.M. Peak Hour	P.M. Peak Hour	8-Hour
0 Feet from Roadway Edge	7.8	8.0	5.4
25 Feet from Roadway Edge	7.2	7.3	5.0
50 Feet from Roadway Edge	7.0	7.1	4.8

**BAY AREA AQMD SIMPLIFIED CALINE4 ANALYSIS; UPDATED WITH EMFAC2007**

Project Title: Evergreen College FMP  
 Intersection: Silver Creek Road and Capitol Expressway  
 Analysis Condition: Cumulative plus Project  
 Nearest Air Monitoring Station measuring CO: Jackson St San Jose  
 Background 1-hour CO Concentration (ppm): 6.2  
 Background 8-hour CO Concentration (ppm): 4.3  
 Persistence Factor: 0.6  
 Analysis Year: 2020

	Roadway Type	No. of Lanes	Approach/Departure Speed	
			A.M.	P.M.
North-South Roadway: Silver Creek Road	AT GRADE	8	5	5
East-West Roadway: Capitol Expressway	AT GRADE	6	5	5

**EMFAC2007 COMPOSITE EMISSION FACTORS FOR CO**

Air Basin: SF Bay Area County: Santa Clara  
 Assumes lowest mean wintertime temperature of 49 degrees F and 71% humidity.

Year	Average Speed (miles per hour)									
	5	8	11	14	17	20	23	26	29	32
2010	6.419	5.647	5.034	4.542	4.142	3.818	3.553	3.333	3.15	3
2011	5.798	5.116	4.572	4.134	3.777	3.487	3.249	3.051	2.886	2.749
2012	5.251	4.645	4.161	3.77	3.451	3.19	2.976	2.797	2.647	2.522
2013	4.757	4.22	3.79	3.44	3.154	2.92	2.728	2.566	2.43	2.316
2014	4.323	3.844	3.46	3.146	2.889	2.679	2.505	2.359	2.235	2.13
2015	3.937	3.51	3.165	2.883	2.651	2.461	2.305	2.172	2.059	1.963
2020	2.646	2.387	2.174	1.997	1.85	1.728	1.627	1.539	1.464	1.398
2025	1.949	1.77	1.621	1.496	1.392	1.306	1.233	1.17	1.115	1.067
2030	1.615	1.471	1.35	1.248	1.163	1.093	1.034	0.983	0.937	0.898
2035	1.403	1.276	1.17	1.081	1.007	0.946	0.896	0.852	0.813	0.779
2040	1.283	1.164	1.065	0.982	0.913	0.858	0.813	0.773	0.738	0.706

**PEAK HOUR TURNING VOLUMES**

A.M. Peak				P.M. Peak			
N	15	2,735	125	N	55	2,935	250
W	<	v	>	W	<	v	>
E	35 ^		165	E	100 ^		140
	361 >		507		416 >		328
	355 v		645		395 v		376
S	<	^	>	S	<	^	>
	545	2,705	350		685	3,060	550

**Representative Traffic Volumes (Vehicles per Hour)**

N-S Road	7,335	N-S Road	8,001
E-W Road	2,153	E-W Road	2,060
Primary Road =	N-S Road	Primary Road =	N-S Road

**ROADWAY CO CONTRIBUTIONS**

Roadway	Reference CO Concentrations			Traffic Volume	Emission Factor
	0 Feet	25 Feet	50 Feet		
<b>A.M. Peak Hour</b>					
N-S Road	8.5	5.7	4.6	* 7,335	* 2.65 ÷ 100,000
E-W Road	2.8	2.3	2.0	* 2,153	* 2.65 ÷ 100,000
<b>P.M. Peak Hour</b>					
N-S Road	8.5	5.7	4.6	* 8,001	* 2.65 ÷ 100,000
E-W Road	2.8	2.3	2.0	* 2,060	* 2.65 ÷ 100,000

**TOTAL CO CONCENTRATIONS (ppm)**

	A.M. Peak Hour	P.M. Peak Hour	8-Hour
0 Feet from Roadway Edge	8.0	8.2	5.5
25 Feet from Roadway Edge	7.4	7.5	5.1
50 Feet from Roadway Edge	7.2	7.3	4.9

**BAY AREA AQMD SIMPLIFIED CALINE4 ANALYSIS; UPDATED WITH EMFAC2007**

Project Title: Hitch Ranch  
 Intersection: Tierra Rejada Rd and New Los Angeles St  
 Analysis Condition: Future (Year 2020) with Project  
 Nearest Air Monitoring Station measuring CO: Simi Valley - Cochran St  
 Background 1-hour CO Concentration (ppm): 6.2  
 Background 8-hour CO Concentration (ppm): 4.3  
 Persistence Factor: 0.7  
 Analysis Year: 2020

Roadway Type	No. of Lanes	Approach/Departure Speed		
		A.M.	P.M.	
North-South Roadway: Tierra Rejada Rd	AT GRADE	4	5	5
East-West Roadway: New Los Angeles St	AT GRADE	4	5	5

**EMFAC2007 COMPOSITE EMISSION FACTORS FOR CO**

Air Basin: South Central Coast County: Ventura  
 Assumes lowest mean wintertime temperature of 49 degrees F and 71% humidity.

Year	Average Speed (miles per hour)									
	5	8	11	14	17	20	23	26	29	32
2010	6.419	5.647	5.034	4.542	4.142	3.818	3.553	3.333	3.15	3
2011	5.798	5.116	4.572	4.134	3.777	3.487	3.249	3.051	2.886	2.749
2012	5.251	4.645	4.161	3.77	3.451	3.19	2.976	2.797	2.647	2.522
2013	4.757	4.22	3.79	3.44	3.154	2.92	2.728	2.566	2.43	2.316
2014	4.323	3.844	3.46	3.146	2.889	2.679	2.505	2.359	2.235	2.13
2015	3.937	3.51	3.165	2.883	2.651	2.461	2.305	2.172	2.059	1.963
2020	2.646	2.387	2.174	1.997	1.85	1.728	1.627	1.539	1.464	1.398
2025	1.949	1.77	1.621	1.496	1.392	1.306	1.233	1.17	1.115	1.067
2030	1.615	1.471	1.35	1.248	1.163	1.093	1.034	0.983	0.937	0.898
2035	1.403	1.276	1.17	1.081	1.007	0.946	0.896	0.852	0.813	0.779
2040	1.283	1.164	1.065	0.982	0.913	0.858	0.813	0.773	0.738	0.706

**PEAK HOUR TURNING VOLUMES**

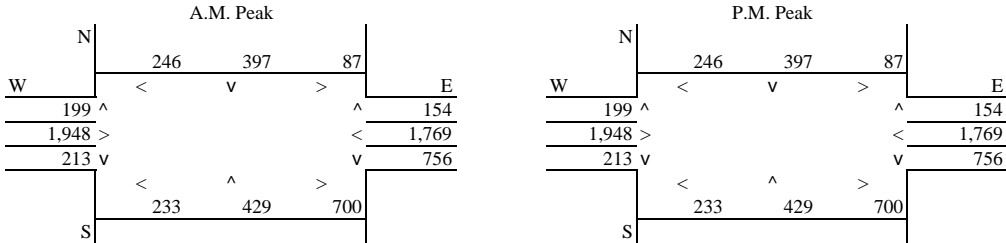

**Representative Traffic Volumes (Vehicles per Hour)**

N-S Road	2,728	N-S Road	2,728
E-W Road	5,414	E-W Road	5,414
Primary Road = E-W Road		Primary Road = E-W Road	

**ROADWAY CO CONTRIBUTIONS**

Roadway	Reference CO Concentrations			Traffic Volume	Emission Factor
	0 Feet	25 Feet	50 Feet		
<b>A.M. Peak Hour</b>					
N-S Road	3.3	2.6	2.2	* 2,728	* 2.65 ÷ 100,000
E-W Road	11.9	7.0	5.4	* 5,414	* 2.65 ÷ 100,000
<b>P.M. Peak Hour</b>					
N-S Road	3.3	2.6	2.2	* 2,728	* 2.65 ÷ 100,000
E-W Road	11.9	7.0	5.4	* 5,414	* 2.65 ÷ 100,000

**TOTAL CO CONCENTRATIONS (ppm)**

	A.M. Peak Hour	P.M. Peak Hour	8-Hour
0 Feet from Roadway Edge	8.1	8.1	5.7
25 Feet from Roadway Edge	7.4	7.4	5.1
50 Feet from Roadway Edge	7.1	7.1	5.0

**APPENDIX 4.5**

---

**Greenhouse Gas Modeling Output**

# Summary Results

Project Name: EVC Existing  
 Project and Baseline Years: 2013 N/A

Results	Unmitigated Project- Baseline CO2e (metric tons/year)	Mitigated Project- Baseline CO2e (metric tons/year)
Transportation:	18,627.98	18,627.98
Area Source:	0.23	0.23
Electricity:	1,602.07	1,602.07
Natural Gas:	766.42	766.42
Water & Wastewater:	24.17	24.17
Solid Waste:	289.07	289.07
Agriculture:	0.00	0.00
Off-Road Equipment:	0.00	0.00
Refrigerants:	0.00	0.00
Sequestration:	N/A	0.00
Purchase of Offsets:	N/A	0.00
<b>Total:</b>	<b>21,309.94</b>	<b>21,309.94</b>

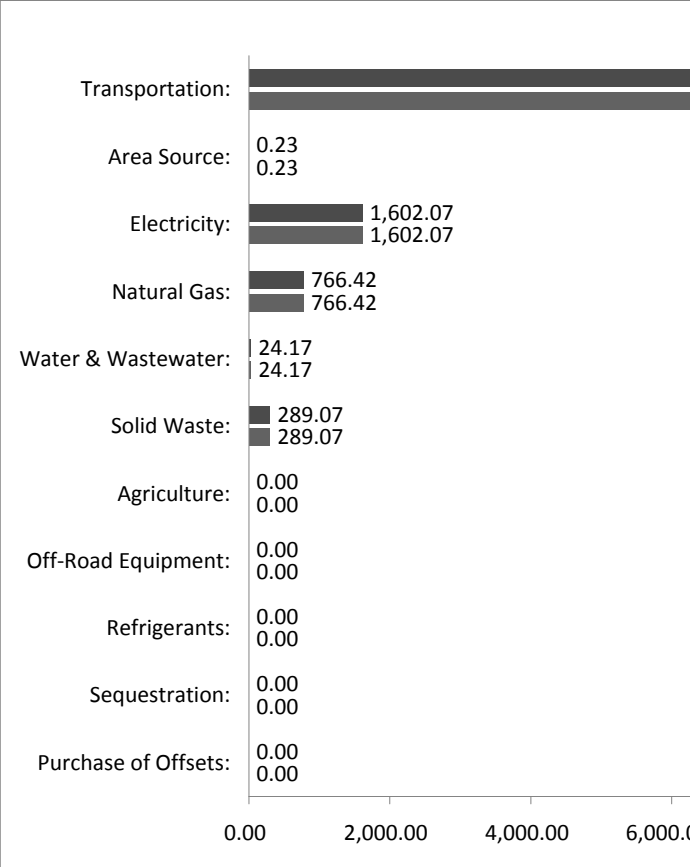

Baseline is currently: **OFF**  
 Baseline Project Name:  
 Go to Settings Tab to Turn On Baseline

## Detailed Results

Unmitigated	CO2 (metric tpy)	CH4 (metric tpy)	N2O (metric tpy)	CO2e (metric tpy)	% of Total
Transportation*:				18,627.98	87.41%
Area Source:	0.23	0.00	0.00	0.23	0.00%
Electricity:	1,599.51	0.01	0.01	1,602.07	7.52%
Natural Gas:	764.46	0.07	0.00	766.42	3.60%
Water & Wastewater:	24.13	0.00	0.00	24.17	0.11%
Solid Waste:	2.11	13.66	N/A	289.07	1.36%
Agriculture:	0.00	0.00	0.00	0.00	0.00%
Off-Road Equipment:	0.00	0.00	0.00	0.00	0.00%
Refrigerants:	N/A	N/A	N/A	0.00	0.00%
Sequestration:	N/A	N/A	N/A	N/A	N/A
Purchase of Offsets:	N/A	N/A	N/A	N/A	N/A
<b>Total:</b>				<b>21,309.94</b>	<b>100.00%</b>

\* Several adjustments were made to transportation emissions after they have been imported from URBEMIS.

After importing from URBEMIS, CO2 emissions are converted to metric tons and then adjusted to account for the "Pavley" regulation. Then, CO2 is converted to CO2e by multiplying by 100/95 to account for the contribution of other GHGs (CH4, N2O, and HFCs [from leaking air conditioning]). Finally, CO2e is adjusted to account for the low carbon fuels rule.

<b>Mitigated</b>	CO2 (metric tpy)	CH4 (metric tpy)	N2O (metric tpy)	CO2e (metric tpy)	% of Total
Transportation*:				18,627.98	87.41%
Area Source:	0.23	0.00	0.00	0.23	0.00%
Electricity:	1,599.51	0.01	0.01	1,602.07	7.52%
Natural Gas:	764.46	0.07	0.00	766.42	3.60%
Water & Wastewater:	24.13	0.00	0.00	24.17	0.11%
Solid Waste:	2.11	13.66	N/A	289.07	1.36%
Agriculture:	0.00	0.00	0.00	0.00	0.00%
Off-Road Equipment:	0.00	0.00	0.00	0.00	0.00%
Refrigerants:	N/A	N/A	N/A	0.00	0.00%
Sequestration:	N/A	N/A	N/A	0.00	0.00%
Purchase of Offsets:	N/A	N/A	N/A	0.00	0.00%
<b>Total:</b>				<b>21,309.94</b>	<b>100.00%</b>

***Mitigation Measures Selected:***

**Transportation:** Go to the following tab: [Transp. Detail Mit](#) for a list of the transportation mitigation measures selected (in URBE

**Electricity:** The following mitigation measure(s) have been selected to reduce electricity emissions.

**Natural Gas:** The following mitigation measure(s) have been selected to reduce natural gas emissions.

**Water and Wastewater:** The following mitigation measure(s) have been selected to reduce water and wastewater emissions.

**Solid Waste:** The following mitigation measure has been selected to reduce solid waste related GHG emissions.

**Ag:** No existing mitigation measures available.

**Off-Road Equipment:** No existing mitigation measures available.

**Refrigerants:** The following mitigation measure has been selected to reduce refrigerant emissions:

**Carbon Sequestration:** Project does not include carbon sequestration through tree planting.

**Emission Offsets/Credits:** Project does not include purchase of emission offsets/credits.





**Project-Baseline CO2e (metric tons/year)**



- Unmitigated
- Mitigated

6,000.00 8,000.00 10,000.00 12,000.00 14,000.00 16,000.00 18,000.00 20,000.00

# Summary Results

Project Name: EVC Proposed  
 Project and Baseline Years: 2025 N/A

**Results**

Transportation:	18,145.94	18,145.94
Area Source:	0.23	0.23
Electricity:	1,649.78	1,649.78
Natural Gas:	789.24	789.24
Water & Wastewater:	24.64	24.64
Solid Waste:	297.57	297.57
Agriculture:	0.00	0.00
Off-Road Equipment:	0.00	0.00
Refrigerants:	0.00	0.00
Sequestration:	N/A	0.00
Purchase of Offsets:	N/A	0.00
<b>Total:</b>	<b>20,907.40</b>	<b>20,907.40</b>

Baseline is currently: **OFF**  
 Baseline Project Name:  
 Go to Settings Tab to Turn On Baseline

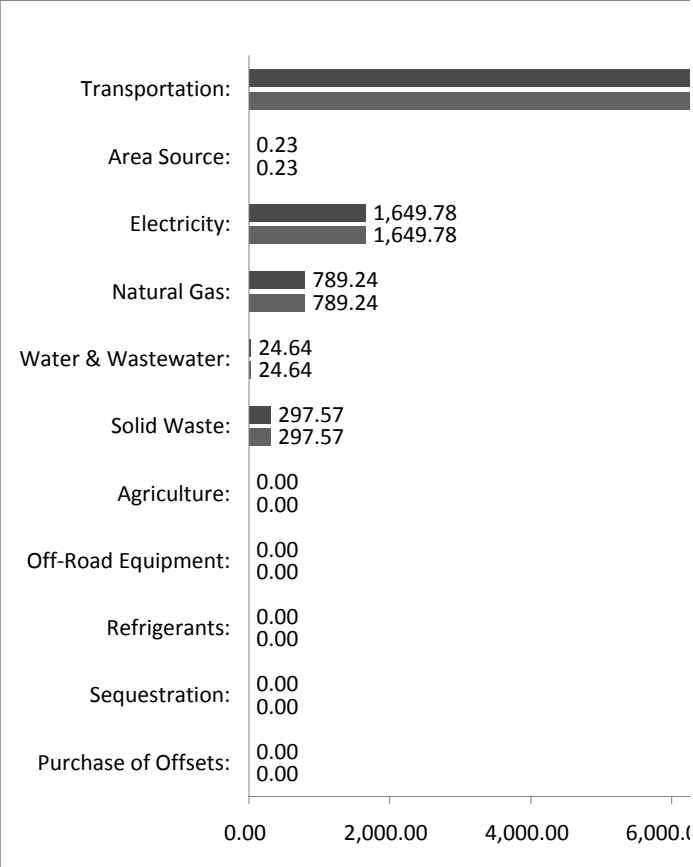

## Detailed Results

Unmitigated	CO2 (metric tpy)	CH4 (metric tpy)	N2O (metric tpy)	CO2e (metric tpy)	% of Total
Transportation*:				18,145.94	86.79%
Area Source:	0.23	0.00	0.00	0.23	0.00%
Electricity:	1,647.14	0.01	0.01	1,649.78	7.89%
Natural Gas:	787.22	0.07	0.00	789.24	3.77%
Water & Wastewater:	24.60	0.00	0.00	24.64	0.12%
Solid Waste:	2.07	14.07	N/A	297.57	1.42%
Agriculture:	0.00	0.00	0.00	0.00	0.00%
Off-Road Equipment:	0.00	0.00	0.00	0.00	0.00%
Refrigerants:	N/A	N/A	N/A	0.00	0.00%
Sequestration:	N/A	N/A	N/A	N/A	N/A
Purchase of Offsets:	N/A	N/A	N/A	N/A	N/A
<b>Total:</b>				<b>20,907.40</b>	<b>100.00%</b>

\* Several adjustments were made to transportation emissions after they have been imported from URBEMIS.

After importing from URBEMIS, CO2 emissions are converted to metric tons and then adjusted to account for the "Pavley" regulation. Then, CO2 is converted to CO2e by multiplying by 100/95 to account for the contribution of other GHGs (CH4, N2O, and HFCs [from leaking air conditioning]). Finally, CO2e is adjusted to account for the low carbon fuels rule.

<b>Mitigated</b>	CO2 (metric tpy)	CH4 (metric tpy)	N2O (metric tpy)	CO2e (metric tpy)	% of Total
Transportation*:				18,145.94	86.79%
Area Source:	0.23	0.00	0.00	0.23	0.00%
Electricity:	1,647.14	0.01	0.01	1,649.78	7.89%
Natural Gas:	787.22	0.07	0.00	789.24	3.77%
Water & Wastewater:	24.60	0.00	0.00	24.64	0.12%
Solid Waste:	2.07	14.07	N/A	297.57	1.42%
Agriculture:	0.00	0.00	0.00	0.00	0.00%
Off-Road Equipment:	0.00	0.00	0.00	0.00	0.00%
Refrigerants:	N/A	N/A	N/A	0.00	0.00%
Sequestration:	N/A	N/A	N/A	0.00	0.00%
Purchase of Offsets:	N/A	N/A	N/A	0.00	0.00%
<b>Total:</b>				<b>20,907.40</b>	<b>100.00%</b>

***Mitigation Measures Selected:***

**Transportation:** Go to the following tab: [Transp. Detail Mit](#) for a list of the transportation mitigation measures selected (in URBE

**Electricity:** The following mitigation measure(s) have been selected to reduce electricity emissions.

**Natural Gas:** The following mitigation measure(s) have been selected to reduce natural gas emissions.

**Water and Wastewater:** The following mitigation measure(s) have been selected to reduce water and wastewater emissions.

**Solid Waste:** The following mitigation measure has been selected to reduce solid waste related GHG emissions.

**Ag:** No existing mitigation measures available.

**Off-Road Equipment:** No existing mitigation measures available.

**Refrigerants:** The following mitigation measure has been selected to reduce refrigerant emissions:

**Carbon Sequestration:** Project does not include carbon sequestration through tree planting.

**Emission Offsets/Credits:** Project does not include purchase of emission offsets/credits.



**Project-Baseline CO2e (metric tons/year)**



- Unmitigated
- Mitigated

6,000.00 8,000.00 10,000.00 12,000.00 14,000.00 16,000.00 18,000.00 20,000.00

**APPENDIX 4.8**

---

**Noise Modeling Output**





**Project Name**  
**On-Site Noise Contours**  
**Existing Conditions**

ROADWAY NAME	Segment	Number of Lanes in Each Direction	Median Width	ADT Volume	Design Speed (mph)	Alpha Factor (1)	Vehicle Mix			Distance from Center of Roadway								
							Medium Trucks	Heavy Trucks	CNEL at 75 Feet	75 CNEL	70 CNEL	65 CNEL	60 CNEL					
ROADWAY NAME																		
S King, west of E Capital Express		2	0	10,160	35	0	1.8%	0.7%	63.0	-	-	-	-	-	-	-	150	
Silver Creek, between E Capital Express and YB Road		2	0	14,230	35	0	1.8%	0.7%	64.5	-	-	-	-	-	-	-	208	
Neiman, North of Aborn		1	0	7,200	25	0	1.8%	0.7%	58.5	-	-	-	-	-	-	-	-	
Neiman, between Aborn and YB Road		1	0	7,580	25	0	1.8%	0.7%	58.7	-	-	-	-	-	-	-	-	
Neiman, South of YB Road		2	0	5,930	35	0	1.8%	0.7%	60.7	-	-	-	-	-	-	88	158	
San Felipe, north of Aborn		2	0	10,710	35	0	1.8%	0.7%	63.3	-	-	-	-	-	-	101	314	
San Felipe, between Aborn and YB Ave		2	0	21,600	35	0	1.8%	0.7%	65.7	-	-	-	-	-	-	88	275	
San Felipe, between YB Ave and Fowler		2	0	18,850	35	0	1.8%	0.7%	65.6	-	-	-	-	-	-	85	264	
San Felipe, between Fowler and Delta		2	0	18,090	35	0	1.8%	0.7%	66.2	-	-	-	-	-	-	98	304	
San Felipe, between Delta and Paseo de Arboles		2	0	20,840	35	0	1.8%	0.7%	66.0	-	-	-	-	-	-	93	289	
San Felipe, between Paseo de Arboles and YB Road		2	0	19,850	35	0	1.8%	0.7%	61.7	-	-	-	-	-	-	110	-	
San Felipe, south of YB Road		2	0	7,420	35	0	1.8%	0.7%	44.4	-	-	-	-	-	-	-	-	
Byington, south of YB Road		1	0	280	25	0	1.8%	0.7%	62.3	-	-	-	-	-	-	-	126	
Aborn, west of E Capital Express		2	0	8,540	35	0	1.8%	0.7%	70.6	-	-	-	-	-	-	264	821	
Aborn, between E Capital Express and Neiman		3	0	30,410	45	0	1.8%	0.7%	70.8	-	-	-	85	-	-	278	864	
Aborn, between Nieman and San Felipe		3	0	32,020	45	0	1.8%	0.7%	65.7	-	-	-	89	-	-	88	272	
Aborn, east of San Felipe		3	0	9,920	45	0	1.8%	0.7%	54.8	-	-	-	-	-	-	-	-	
YB Ave, west of San Felipe		1	0	3,070	25	0	1.8%	0.7%	53.3	-	-	-	-	-	-	-	-	
Fowler, east of San Felipe		1	0	2,180	25	0	1.8%	0.7%	58.0	-	-	-	-	-	-	-	-	
Delta, east of San Felipe		1	0	4,340	25	0	1.8%	0.7%	63.7	-	-	-	-	-	-	-	-	
Paseo de Arboles, east of San Felipe		2	0	6,320	25	0	1.8%	0.7%	66.3	-	-	-	-	-	-	-	-	
YB Road, west of Silver Creek		2	0	11,800	35	0	1.8%	0.7%	66.8	-	-	-	-	-	-	-	-	
YB Road, between Silver Creek and Neiman		2	0	22,280	35	0	1.8%	0.7%	66.8	-	-	-	-	-	-	-	-	
YB Road, between Neiman and Byington		2	0	23,990	35	0	1.8%	0.7%	66.8	-	-	-	-	-	-	-	-	
YB Road, between Byington and San Felipe		2	0	24,010	35	0	1.8%	0.7%	67.6	-	-	-	-	-	-	-	-	
YB Road, east of San Felipe		2	0	9,230	35	0	1.8%	0.7%	67.6	-	-	-	-	-	-	-	-	

**Notes:**

(1) Alpha Factor: Coefficient of absorption relating to the effects of the ground surface. An alpha factor of 0 indicates that the site is an acoustically "hard" site, such as asphalt. An alpha factor of 0.5 indicates that the site is an acoustically "soft" site such as heavily vegetated ground cover.  
 \*w = contour is located within the roadway lanes or within 75 feet of the roadway centerline.  
 Noise levels and distances to contours do not assume any natural or constructed barriers that may attenuate noise.

**Assumed 24-Hour Traffic Distribution:**

	Day	Evening	Night	Total
Total ADT Volumes	77.70%	12.70%	9.60%	100.00%
Medium-Duty Trucks	87.43%	5.03%	7.52%	100.00%
Heavy-Duty Trucks	89.10%	2.84%	8.06%	100.00%

Notes to Modeler: The 24-hour traffic distribution and vehicle mix percentages are defaults. For project-specific numbers, obtain the 24-hour traffic distribution, vehicle mix percentages, and traffic volumes from the traffic engineer. Impact studies on federal highways, obtain this information from the Caltrans website. Column G under Notes: should total 100%. Some jurisdictions have different distributions by roadway type, so check with that jurisdiction. An example is Riverside County.

**Project Name**  
**On-Site Noise Contours**  
**Existing + Project Conditions**

ROADWAY NAME	Segment	Number of Lanes in Each Direction	Median Width	ADT Volume	Design Speed (mph)	Alpha Factor (I)	Vehicle Mix Medium Trucks	Vehicle Mix Heavy Trucks	Distance from Center of Roadway DISTANCE TO CONTOUR											
									CNEL at 75 Feet	75 CNEL	70 CNEL	65 CNEL	60 CNEL							
ROADWAY NAME																				
S King, west of E Capital Express		2	0	10,190	35	0	1.8%	0.7%	63.1	-	-	-	-	-	-	-	-	-	-	150
Silver Creek, between E Capital Express and YB Road		2	0	14,630	35	0	1.8%	0.7%	64.6	-	-	-	-	-	-	-	-	-	-	214
Neiman, North of Aborn		1	0	7,320	25	0	1.8%	0.7%	58.6	-	-	-	-	-	-	-	-	-	-	-
Neiman, between Aborn and YB Road		1	0	7,720	25	0	1.8%	0.7%	58.8	-	-	-	-	-	-	-	-	-	-	-
Neiman, South of YB Road		2	0	6,210	35	0	1.8%	0.7%	60.9	-	-	-	-	-	-	-	-	-	-	92
San Felipe, north of Aborn		2	0	10,840	35	0	1.8%	0.7%	63.3	-	-	-	-	-	-	-	-	-	-	159
San Felipe, between Aborn and YB Ave		2	0	22,820	35	0	1.8%	0.7%	66.6	-	-	-	-	-	-	-	-	-	-	332
San Felipe, between YB Ave and Fowler		2	0	20,070	35	0	1.8%	0.7%	66.0	-	-	-	-	-	-	-	-	-	-	292
San Felipe, between Fowler and Delta		2	0	19,100	35	0	1.8%	0.7%	65.8	-	-	-	-	-	-	-	-	-	-	279
San Felipe, between Delta and Paseo de Arboles		2	0	21,850	35	0	1.8%	0.7%	66.4	-	-	-	-	-	-	-	-	-	-	318
San Felipe, between Paseo de Arboles and YB Road		2	0	21,770	35	0	1.8%	0.7%	66.4	-	-	-	-	-	-	-	-	-	-	317
San Felipe, south of YB Road		2	0	7,560	35	0	1.8%	0.7%	61.8	-	-	-	-	-	-	-	-	-	-	112
Byington, south of YB Road		1	0	280	25	0	1.8%	0.7%	44.4	-	-	-	-	-	-	-	-	-	-	-
Aborn, west of E Capital Express		2	0	8,560	35	0	1.8%	0.7%	62.3	-	-	-	-	-	-	-	-	-	-	126
Aborn, between E Capital Express and Nieman		3	0	30,500	45	0	1.8%	0.7%	70.6	-	-	-	-	-	-	-	-	-	-	824
Aborn, between Nieman and San Felipe		3	0	32,630	45	0	1.8%	0.7%	70.9	-	-	-	-	-	-	-	-	-	-	880
Aborn, east of San Felipe		3	0	10,000	45	0	1.8%	0.7%	65.7	-	-	-	-	-	-	-	-	-	-	275
YB Ave, west of San Felipe		1	0	3,070	25	0	1.8%	0.7%	54.8	-	-	-	-	-	-	-	-	-	-	-
Fowler, east of San Felipe		1	0	2,180	25	0	1.8%	0.7%	53.3	-	-	-	-	-	-	-	-	-	-	-
Delta, east of San Felipe		1	0	4,340	25	0	1.8%	0.7%	56.5	-	-	-	-	-	-	-	-	-	-	-
Paseo de Arboles, east of San Felipe		2	0	7,580	25	0	1.8%	0.7%	58.7	-	-	-	-	-	-	-	-	-	-	-
YB Road, west of Silver Creek		2	0	11,990	35	0	1.8%	0.7%	63.8	-	-	-	-	-	-	-	-	-	-	176
YB Road, between Silver Creek and Nieman		2	0	23,790	35	0	1.8%	0.7%	66.7	-	-	-	-	-	-	-	-	-	-	346
YB Road, between Nieman and Byington		2	0	25,700	35	0	1.8%	0.7%	67.1	-	-	-	-	-	-	-	-	-	-	373
YB Road, between Byington and San Felipe		2	0	26,080	35	0	1.8%	0.7%	67.1	-	-	-	-	-	-	-	-	-	-	379
YB Road, east of San Felipe		2	0	10,460	35	0	1.8%	0.7%	63.2	-	-	-	-	-	-	-	-	-	-	154

**Notes:**

(1) Alpha Factor: Coefficient of absorption relating to the effects of the ground surface. An alpha factor of 0 indicates that the site is an acoustically "hard" site, such as asphalt. An alpha factor of 0.5 indicates that the site is an acoustically "soft" site such, as heavily vegetated ground cover.

"n" = contour is located within the roadway lanes or within 75 feet of the roadway centerline.

Noise levels and distances to contours do not assume any natural or constructed barriers that may attenuate noise.

**Assumed 24-Hour Traffic Distribution:**

Total ADT Volumes	Day	Evening	Night	Total
87,43%	77.70%	12.70%	9.60%	100.00%
Medium-Duty Trucks	89.10%	5.05%	7.52%	100.00%
Heavy-Duty Trucks	89.10%	2.84%	8.06%	100.00%

Notes to Modeler: The 24-hour traffic distribution and vehicle mix percentages are defaults. For project-specific numbers, obtain the 24-hour traffic distribution, vehicle mix percentages, and traffic volumes from the traffic engineer. Impact studies on federal highways, obtain this information from the Caltrans website. Column G under Notes: should total 100%. Some jurisdictions have different distributions by roadway type, so check with that jurisdiction. An example is Riverside County.

Date:

**Project Name**  
**On-Site Noise Contours**  
**2025 No Project**

ROADWAY NAME	Segment	Number of Lanes in Each Direction	Median Width	ADT Volume	Design Speed (mph)	Alpha Factor (I)	Vehicle Mix		Distance from Center of Roadway											
							Medium Trucks	Heavy Trucks	CNEL at 75 Feet	75 CNEL	70 CNEL	65 CNEL	60 CNEL							
ROADWAY NAME																				
S King, west of E Capitol Express		2	0	10,650	35	0	1.8%	0.7%	63.2	-	-	-	-	-	-	-	-	-	-	157
Silver Creek, between E Capitol Express and YB Road		2	0	15,500	35	0	1.8%	0.7%	64.9	-	-	-	-	-	-	-	-	-	-	227
Neiman, North of Aborn		1	0	8,450	25	0	1.8%	0.7%	59.2	-	-	-	-	-	-	-	-	-	-	-
Neiman, between Aborn and YB Road		1	0	8,100	25	0	1.8%	0.7%	59.0	-	-	-	-	-	-	-	-	-	-	-
Neiman, South of YB Road		2	0	6,500	35	0	1.8%	0.7%	61.1	-	-	-	-	-	-	-	-	-	-	96
San Felipe, north of Aborn		2	0	16,500	35	0	1.8%	0.7%	65.2	-	-	-	-	-	-	-	-	-	-	241
San Felipe, between Aborn and YB Ave		2	0	32,150	35	0	1.8%	0.7%	66.0	-	-	-	-	-	-	-	-	-	-	465
San Felipe, between YB Ave and Fowler		2	0	29,050	35	0	1.8%	0.7%	67.6	-	-	-	-	-	-	-	-	-	-	421
San Felipe, between Fowler and Delta		2	0	22,700	35	0	1.8%	0.7%	66.5	-	-	-	-	-	-	-	-	-	-	330
San Felipe, between Delta and Paseo de Arboles		2	0	24,950	35	0	1.8%	0.7%	66.9	-	-	-	-	-	-	-	-	-	-	362
San Felipe, between Paseo de Arboles and YB Road		2	0	27,950	35	0	1.8%	0.7%	67.4	-	-	-	-	-	-	-	-	-	-	405
San Felipe, south of YB Road		2	0	10,150	35	0	1.8%	0.7%	63.0	-	-	-	-	-	-	-	-	-	-	149
Byington, south of YB Road		1	0	600	25	0	1.8%	0.7%	47.7	-	-	-	-	-	-	-	-	-	-	-
Aborn, west of E Capitol Express		2	0	8,850	35	0	1.8%	0.7%	62.4	-	-	-	-	-	-	-	-	-	-	131
Aborn, between E Capitol Express and Neiman		3	0	56,850	45	0	1.8%	0.7%	73.3	-	-	-	-	-	-	-	-	-	-	1,521
Aborn, between Neiman and San Felipe		3	0	62,100	45	0	1.8%	0.7%	73.7	-	-	-	-	-	-	-	-	-	-	1,659
Aborn, east of San Felipe		3	0	21,850	45	0	1.8%	0.7%	69.1	-	-	-	-	-	-	-	-	-	-	593
YB Ave, west of San Felipe		1	0	3,250	25	0	1.8%	0.7%	55.1	-	-	-	-	-	-	-	-	-	-	-
Fowler, east of San Felipe		1	0	3,200	25	0	1.8%	0.7%	55.0	-	-	-	-	-	-	-	-	-	-	-
Delta, east of San Felipe		1	0	5,030	25	0	1.8%	0.7%	57.0	-	-	-	-	-	-	-	-	-	-	-
Paseo de Arboles, east of San Felipe		2	0	6,300	25	0	1.8%	0.7%	57.9	-	-	-	-	-	-	-	-	-	-	-
YB Road, west of Silver Creek		2	0	22,500	35	0	1.8%	0.7%	66.5	-	-	-	-	-	-	-	-	-	-	327
YB Road, between Silver Creek and Neiman		2	0	43,550	35	0	1.8%	0.7%	69.4	-	-	-	-	-	-	-	-	-	-	627
YB Road, between Neiman and Byington		2	0	42,200	35	0	1.8%	0.7%	69.2	-	-	-	-	-	-	-	-	-	-	608
YB Road, between Byington and San Felipe		2	0	47,100	35	0	1.8%	0.7%	69.7	-	-	-	-	-	-	-	-	-	-	678
YB Road, east of San Felipe		2	0	17,850	35	0	1.8%	0.7%	65.5	-	-	-	-	-	-	-	-	-	-	261

**Notes:**  
 (1) Alpha Factor: Coefficient of absorption relating to the effects of the ground surface. An alpha factor of 0 indicates that the site is an acoustically "hard" site, such as asphalt. An alpha factor of 0.5 indicates that the site is an acoustically "soft" site such, as heavily vegetated ground cover.  
 "n" = contour is located within the roadway lanes or within 75 feet of the roadway centerline.  
 Noise levels and distances to contours do not assume any natural or constructed barriers that may attenuate noise.

**Assumed 24-Hour Traffic Distribution:**

	Day	Evening	Night	Total
Total ADT Volumes	77.70%	12.70%	9.60%	100.00%
Medium-Duty Trucks	87.43%	5.05%	7.52%	100.00%
Heavy-Duty Trucks	89.10%	2.84%	8.06%	100.00%

**Notes to Modeler:** The 24-hour traffic distribution and vehicle mix percentages are defaults. For project-specific numbers, obtain the 24-hour traffic distribution, vehicle mix percentages, and traffic volumes from the traffic engineer. For project-specific and federal highways, obtain this information from the Caltrans website. Column G under Notes: should total 100%. Some jurisdictions have different distributions by roadway type, so check with that jurisdiction. An example is Riverside County.

**Project Name**  
**On-Site Noise Contours**  
**2025 + Project Conditions**

ROADWAY NAME	Segment	Number of Lanes in Each Direction	Median Width	ADT Volume	Design Speed (mph)	Alpha Factor (1)	Vehicle Mix		CNEL at 75 Feet	Distance from Center of Roadway								
							Medium Trucks	Heavy Trucks		75 CNEL	70 CNEL	65 CNEL	60 CNEL					
ROADWAY NAME																		
S King, west of E Capital Express		2	0	10,680	35	0	1.8%	0.7%	63.3	-	-	-	-	-	-	-	-	157
Silver Creek, Between E Capital Express and YB Road		2	0	15,900	35	0	1.8%	0.7%	65.0	-	-	-	-	-	-	-	-	233
Neiman, North of Aborn		1	0	8,570	25	0	1.8%	0.7%	59.3	-	-	-	-	-	-	-	-	-
Neiman, Between Aborn and YB Road		1	0	8,240	25	0	1.8%	0.7%	59.1	-	-	-	-	-	-	-	-	-
Neiman, South of YB Road		2	0	6,630	35	0	1.8%	0.7%	61.2	-	-	-	-	-	-	-	-	98
San Felipe, north of Aborn		2	0	16,630	35	0	1.8%	0.7%	65.2	-	-	-	-	-	-	-	-	243
San Felipe, between Aborn and YB Ave		2	0	33,370	35	0	1.8%	0.7%	68.2	-	-	-	-	-	-	-	-	483
San Felipe, between YB Ave and Fowler		2	0	30,270	35	0	1.8%	0.7%	67.8	-	-	-	-	-	-	-	-	438
San Felipe, between Fowler and Delta		2	0	23,710	35	0	1.8%	0.7%	66.7	-	-	-	-	-	-	-	-	345
San Felipe, between Delta and Paseo de Arboles		2	0	25,960	35	0	1.8%	0.7%	67.1	-	-	-	-	-	-	-	-	377
San Felipe, between Paseo de Arboles and YB Road		2	0	29,870	35	0	1.8%	0.7%	67.7	-	-	-	-	-	-	-	-	433
San Felipe, south of YB Road		2	0	10,290	35	0	1.8%	0.7%	63.1	-	-	-	-	-	-	-	-	152
Byington, south of YB Road		1	0	600	25	0	1.8%	0.7%	47.7	-	-	-	-	-	-	-	-	-
Aborn, west of E Capital Express		2	0	8,370	35	0	1.8%	0.7%	62.5	-	-	-	-	-	-	-	-	131
Aborn, between E Capital Express and Neiman		3	0	56,940	45	0	1.8%	0.7%	73.3	-	-	-	-	-	-	-	-	1,523
Aborn, between Neiman and San Felipe		3	0	62,710	45	0	1.8%	0.7%	73.7	-	-	-	158	490	539	1,675	-	-
Aborn, east of San Felipe		3	0	21,930	45	0	1.8%	0.7%	69.1	-	-	-	173	192	595	-	-	-
YB Ave, west of San Felipe		1	0	3,250	25	0	1.8%	0.7%	55.1	-	-	-	-	-	-	-	-	-
Fowler, east of San Felipe		1	0	3,200	25	0	1.8%	0.7%	55.0	-	-	-	-	-	-	-	-	-
Delta, east of San Felipe		1	0	5,030	25	0	1.8%	0.7%	57.0	-	-	-	-	-	-	-	-	-
Paseo de Arboles, east of San Felipe		2	0	7,560	25	0	1.8%	0.7%	58.7	-	-	-	-	-	-	-	-	-
YB Road, west of Silver Creek		2	0	22,440	35	0	1.8%	0.7%	66.5	-	-	-	-	-	-	-	-	326
YB Road, between Silver Creek and Neiman		2	0	45,060	35	0	1.8%	0.7%	69.5	-	-	-	-	-	-	-	-	649
YB Road, between Neiman and Byington		2	0	43,910	35	0	1.8%	0.7%	69.4	-	-	-	-	-	-	-	-	632
YB Road, between Byington and San Felipe		2	0	49,170	35	0	1.8%	0.7%	69.9	-	-	-	-	-	-	-	-	707
YB Road, east of San Felipe		2	0	19,080	35	0	1.8%	0.7%	65.8	-	-	-	-	-	-	-	-	278

**Notes:**

(1) Alpha Factor: Coefficient of absorption relating to the effects of the ground surface. An alpha factor of 0 indicates that the site is an acoustically "hard" site, such as asphalt. An alpha factor of 0.5 indicates that the site is an acoustically "soft" site such, as heavily vegetated ground cover.  
 "H" = contour is located within the roadway lanes or within 75 feet of the roadway centerline.  
 Noise levels and distances to contours do not assume any natural or constructed barriers that may attenuate noise.

Assumed 24-Hour Traffic Distribution:	Day	Evening	Night	Total
Total ADT Volumes	77.70%	12.70%	9.60%	100.00%
Medium-Duty Trucks	87.43%	5.05%	7.52%	100.00%
Heavy-Duty Trucks	89.10%	2.84%	8.06%	100.00%

Notes to Modeler: The 24-hour traffic distribution and vehicle mix percentages are defaults. For project-specific numbers, obtain the 24-hour traffic distribution, vehicle mix percentages, and traffic volumes from the traffic engineer. For project-specific and federal highways, obtain this information from the Caltrans website. Column G under Notes: should total 100%. Some jurisdictions have different distributions by roadway type, so check with that jurisdiction. An example is Riverside County.

**APPENDIX 4.10**

---

**Traffic Technical Report**

FEHR PEERS

160 W. Santa Clara St., Ste. 675  
San Jose, CA 95113

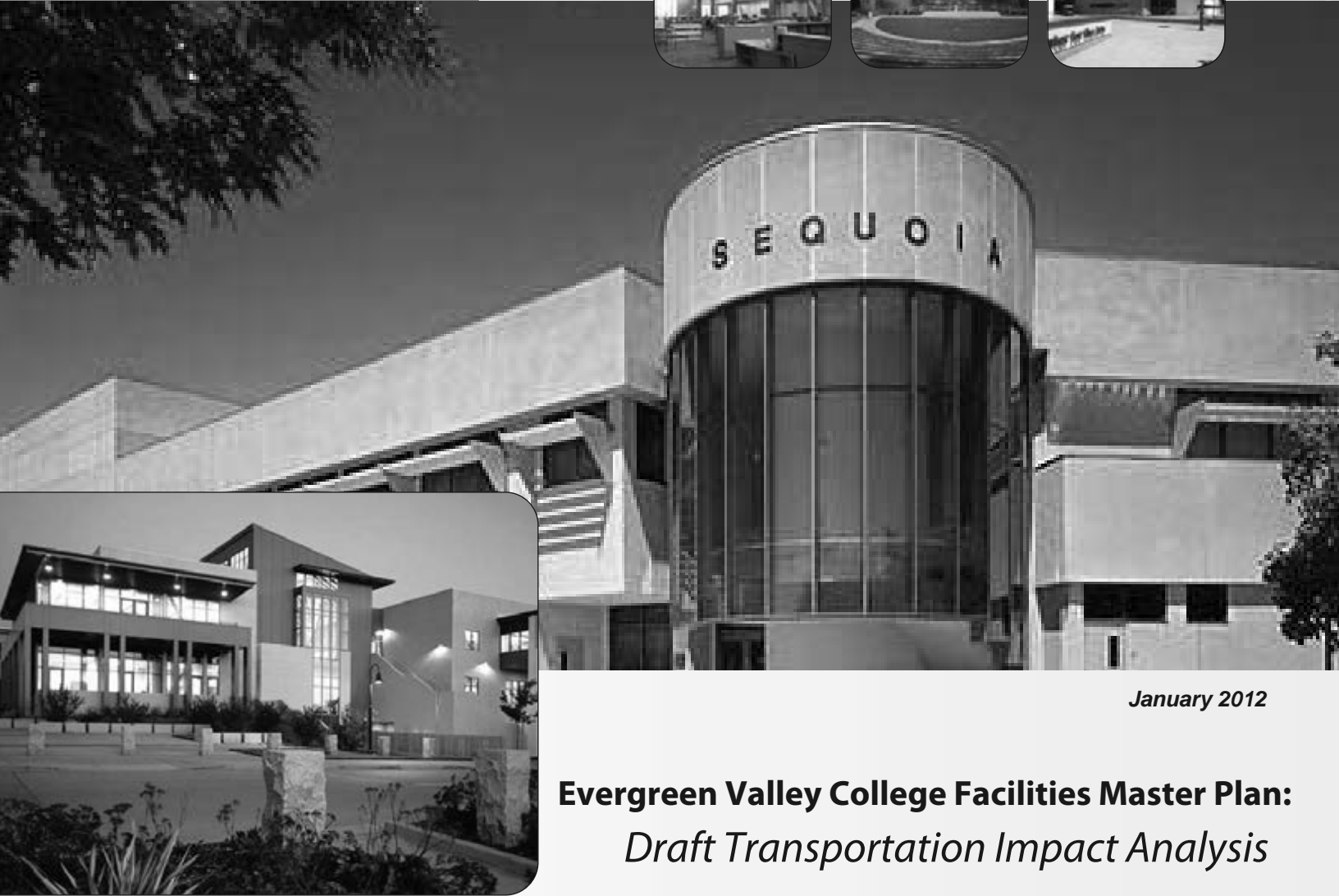

*January 2012*

**Evergreen Valley College Facilities Master Plan:**  
*Draft Transportation Impact Analysis*

# **Evergreen Valley College Facilities Master Plan Transportation Impact Analysis**

Prepared for:

**San Jose/Evergreen Community College District**

Prepared by:

**Fehr & Peers**

January, 2012

## TABLE OF CONTENTS

<b>EXECUTIVE SUMMARY .....</b>	<b>i</b>
Project Traffic Estimates.....	i
Intersection Impacts .....	i
Freeway Segment Impacts.....	ii
Pedestrian, Bicycle, and Transit Facility Impacts.....	ii
Site Access, On-Site Circulation, and Parking .....	iii
<b>1. INTRODUCTION .....</b>	<b>1</b>
Project Study Area.....	1
Intersection Analysis Scenarios.....	2
Traffic Analysis Methods .....	2
Report Organization .....	4
<b>2. EXISTING CONDITIONS .....</b>	<b>7</b>
Existing Roadway Network.....	7
Existing Pedestrian and Bicycle Facilities .....	7
Existing Transit Service.....	10
Existing Volumes and Lane Configurations.....	12
Existing Freeway Segment Levels of Service .....	15
<b>3. EXISTING PLUS PROJECT CONDITIONS .....</b>	<b>16</b>
Project Traffic Estimates.....	16
Existing Plus Project Intersection Levels of Service.....	21
Intersection Impact Criteria.....	22
Intersection Impacts .....	23
Existing Plus Project Freeway Segment Levels of Service .....	23
Freeway Impacts .....	24
Pedestrian, Bicycle, and Transit Facility Impacts .....	24
Site Access and On-Site Circulation.....	25
Parking.....	25
<b>4. CUMULATIVE CONDITIONS .....</b>	<b>27</b>
Cumulative Traffic Estimates.....	27
Cumulative Roadway Improvements.....	27
Cumulative Intersection Levels of Service .....	27
Project Impacts and Mitigation Measures .....	29

## APPENDICES

Appendix A: Existing Traffic Counts

Appendix B: Intersection Level of Service Calculations

Appendix C: Approved & Pending Projects



## LIST OF FIGURES

Figure 1	Project Location, Study Intersections, and Freeway Study Segments .....	5
Figure 2	Proposed Master Plan .....	6
Figure 3	Existing Pedestrian and Bicycle Facilities .....	9
Figure 4	Existing Transit Service .....	11
Figure 5	Existing Lane Geometries, Traffic Controls, and Peak-Hour Intersection Volumes.....	13
Figure 6	Project Trip Distribution .....	18
Figure 7	Project Trip Assignment .....	19
Figure 8	Existing Plus Project Lane Geometries, Traffic Controls, and Peak-Hour Intersection Volumes ..	20
Figure 9	Cumulative No Project Lane Geometries, Traffic Controls, and Peak-Hour Intersection Volumes ... .....	31
Figure 10	Cumulative Plus Project Lane Geometries, Traffic Controls, and Peak-Hour Intersection Volumes. .....	32

## LIST OF TABLES

Table 1	Signalized Intersection Level of Service Definitions Using Average Control Vehicular Delay .....	3
Table 2	Freeway Segment Level of Service Definitions .....	3
Table 3	VTA Ridership and Capacity at the Maximum Load Point – Existing Conditions .....	10
Table 4	Existing Intersection Levels of Service .....	14
Table 5	Existing Freeway Segment Levels of Service.....	15
Table 6	Project Trip Generation Rates and Estimates .....	17
Table 7	Existing and Existing Plus Project Intersection Levels of Service .....	21
Table 8	Existing Plus Project Freeway Segment Levels of Service .....	24
Table 9	Cumulative and Cumulative Plus Project Intersection Levels of Service .....	27

## EXECUTIVE SUMMARY

This report presents the results of the transportation impact analysis (TIA) for the Facilities Master Plan of the Evergreen Valley College (EVC) located in Santa Clara County, California. EVC is bounded by Falls Creek Drive to the north, San Felipe Road to the west, and Yerba Buena Road to the east and south.

The *Educational and Facilities Master Plan Update – 2025* (June 22, 2010) is a comprehensive plan highlighting the future educational and facility needs of the College. The plan projects an annual student population growth rate of 1.84 percent through 2025, resulting in an increase in the student population of approximately 2,863 students over the life of the plan. To accommodate the projected growth, the Project includes construction of a new Arts Complex and Physical Education expansion, in conjunction with other facilities, totaling 42,800 square-feet.

The analysis was conducted to identify potential transportation impacts of the proposed project on the surrounding roadway system and to recommend appropriate improvements to mitigate significant impacts. The roadway system was evaluated under Existing, Existing plus Project, Cumulative no Project and Cumulative plus Project Conditions.

### PROJECT TRAFFIC ESTIMATES

The amount of traffic generated by the proposed project was estimated by applying rates based on data collected at the San Jose City College driveways. Community college trip generation rates per student were determined for the AM and PM peak hours. The proposed project is estimated to generate 3,981 net new daily trips, 315 new AM peak-hour trips (251 inbound and 64 outbound) and 381 new PM peak-hour trips (249 inbound and 132 outbound).

### INTERSECTION IMPACTS

#### ***US 101 SB Off-Ramp & Yerba Buena Road***

The proposed Project would result in a ***significant impact*** at the US 101 SB Off-Ramp / Yerba Buena Road signalized intersection in the cumulative condition. This intersection operates at an unacceptable LOS F under both the AM and PM peak hour conditions without the addition of project related trips. Project related increases would satisfy either the V/C or vehicle delay thresholds.

The US 101 SB Off-Ramp / Yerba Buena Road signalized intersection is physically constrained. To improve operating conditions to an acceptable level, widening of the intersection to provide additional capacity would be required. Substantial improvement could only be accomplished through extensive demolition and reconstruction of facilities and/or right-of-way acquisition; therefore, the measure was not further considered. Additionally, this intersection is a Caltrans facility and even if there were not physical constraints, implementation of improvements cannot be guaranteed by the City. Traffic impacts at this intersection under the Cumulative Plus Project conditions would remain ***significant and unavoidable***.

#### ***San Felipe Road & Yerba Buena Road***

The proposed Project would result in ***significant impact*** at the San Felipe Road / Yerba Buena Road signalized intersection in the cumulative condition. This intersection operates at an unacceptable LOS E under both the AM and PM peak hour conditions without the addition of project related trips. Project related increases would satisfy either the V/C or vehicle delay thresholds.

*Mitigation Measure:* Construct a second eastbound left-turn.

With implementation of this mitigation measure, operations at this intersection would improve to an acceptable LOS D in both the AM and PM peak hours. Installation of the second eastbound left-turn lane

would require reconstruction of the center median and restriping of the eastbound lanes, but should not require additional right-of-way. Construction of the mitigation measure shall be the responsibility of the City. With the installation of this mitigation measure, the traffic impact at the San Felipe Road / Yerba Buena Road intersection would be reduced to a **less-than-significant impact**.

#### ***Aborn Road & White Road / San Felipe Road***

The proposed Project would result in **significant impact** at the Aborn Road & White Road / San Felipe Road signalized intersection in the cumulative condition. This intersection operates at an unacceptable LOS E under the PM peak hour conditions without the addition of project related trips and the addition of Project trips would increase the V/C or vehicle delay thresholds beyond acceptable limits. Additionally, Project related trips worsen acceptable LOS D to unacceptable LOS E conditions during the AM peak hour.

*Mitigation Measure:* Construct a second westbound left-turn.

With implementation of this mitigation measure, operations at this intersection would improve to an acceptable LOS D during the AM peak hour. The PM peak hour would continue to operate at LOS E; however, delay and V/C would no longer trigger the threshold of significance. Installation of the second westbound left-turn lane would require restriping of the center median and would not require additional right-of-way. Construction of the mitigation measure shall be the responsibility of the City. With the installation of this mitigation measure, the traffic impact at the Aborn Road & White Road / San Felipe Road intersection would be reduced to a **less-than-significant impact**.

#### ***East Capitol Expressway & Aborn Road***

The East Capitol Expressway / Aborn Road intersection operates at an unacceptable LOS F under Cumulative No Project and Cumulative Plus Project Conditions during the AM and PM peak hour. The increase in critical V/C and delay does not exceed the one percent and four second threshold, respectively. Therefore, the impact to this intersection would be considered **less-than-significant**.

#### ***East Capitol Expressway & Silver Creek Road***

The East Capitol Expressway / Aborn Road intersection operates at an unacceptable LOS E under Existing and Existing plus Project Conditions during the PM peak hour but is not considered a significant impact because the increase in critical V/C and delay did not exceed the one percent and four second threshold, respectively. Therefore, the impact to this intersection would be considered **less-than-significant**.

The East Capitol Expressway / Silver Creek Road intersection operates at an unacceptable LOS E under Cumulative No Project and Cumulative Plus Project Conditions during the AM peak hour. The increase in critical V/C and delay does not exceed the one percent and four second threshold, respectively. Therefore, the impact to this intersection would be considered **less-than-significant**.

### **FREEWAY SEGMENT IMPACTS**

The proposed Project would not significantly impact any study freeway segments in the study area.

### **PEDESTRIAN, BICYCLE, AND TRANSIT FACILITY IMPACTS**

The proposed Project would not significantly impact pedestrian, bicycle, or transit facilities in the study area because the proposed project does not conflict with any existing or proposed pedestrian, bicycle, or transit facilities and the proposed Project does not create hazardous conditions for pedestrians, bicyclists, or transit riders.

## SITE ACCESS, ON-SITE CIRCULATION, AND PARKING

### **Site Access**

The EVC campus can currently be accessed from locations along San Felipe Road and Yerba Buena Road. Site access is considered adequate for the volume of traffic generated by the site. Paseo de Arboles would be maintained as the primary access to San Felipe Road and would continue to be controlled by a signalized intersection at San Felipe Road. Valle del Laeo, which currently provides access to Yerba Buena Road, will be converted to a pedestrian pathway. However, several new vehicular access points would be constructed along Yerba Buena Road. The access points would have little conflicting traffic and would be stop-controlled intersections. Based on the trip generation estimates, forecasted demand would be adequately served by these access points. Driveway spacing and sight distance at the new driveways would be adequate.

### **On-Site Circulation**

On-site circulation would be provided by internal roadways and driveways. These facilities would connect the various parking lots to each other. While a connection is currently provided around the perimeter of the campus, it is not designed as a formal roadway. The Facilities Master Plan identifies a loop road that connects Paseo de Arboles and the west side of the campus to the new access on the east side of campus. The inner core of campus would provide a series of interconnected pedestrian pathways, including a central pedestrian promenade that connects the west plaza and east plaza.

Generally, bicycles are not allowed to be ridden through the campus core. The site plan shows ample bicycle parking along the periphery of the campus core adjacent to campus buildings

### **Parking**

The proposed Project would result in a **potentially significant impact** if a construction management and phasing plan is not developed to ensure adequate parking is provided throughout the implementation of the Facilities Master Plan.

*Mitigation Measure:* Develop a Construction Management Plan and Project Phasing.

With implementation of this mitigation measure, adequate parking for levels of enrollment during different phases of construction can be secured. Temporary parking or travel demand management may be acceptable tools used to manage parking demands. With the execution of this mitigation measure, the impact to parking would be reduced to a **less-than-significant impact**.

# 1. INTRODUCTION

This report presents the analysis and findings of the Transportation Impact Analysis (TIA) for the Evergreen Valley College (EVC) Facilities Master Plan (Project). EVC is located in San Jose, California and the campus is bound by Falls Creek Drive to the north, San Felipe Road to the west, and Yerba Buena Road to the east and south.

The *Educational and Facilities Master Plan Update – 2025* (June 22, 2010) is a comprehensive plan highlighting the future educational and facility needs of the College. The plan projects an annual student population growth rate of 1.84 percent through 2025, resulting in an increase in the student population of approximately 2,863 students over the life of the plan. To accommodate the projected growth, the Project includes construction of a new Arts Complex and Physical Education expansion, in conjunction with other facilities, totaling 42,800 square-feet.

## PROJECT STUDY AREA

The analysis was conducted to identify potential Project impacts to the transportation system and identifies improvements to mitigate any significant impacts. **Figure 1** presents the Project location, surrounding roadway system, study intersections, and freeway study segments. The proposed Evergreen Valley College Facilities Master Plan is shown on **Figure 2**.

### *Study Intersections*

Project impacts were evaluated following the guidelines of the City of San Jose, the Santa Clara Valley Transportation Authority (VTA), which is the congestion management agency for Santa Clara County, and the California Department of Transportation (Caltrans). The analysis evaluated the operations of the following key intersections which were selected based on the amount of new traffic that could be added to the intersection by the proposed Project:

1. U.S. 101 SB Off-ramp/Yerba Buena Road\*
2. U.S. 101 NB Off-ramp/Yerba Buena Road\*
3. Silver Creek Road/Yerba Buena Road
4. Nieman Boulevard/Silver Creek Valley Road/Yerba Buena Road
5. Byington Drive/Yerba Buena Avenue/Yerba Buena Road
6. San Felipe Road/Yerba Buena Road
7. Paseo de Arboles/San Felipe Road
8. Delta Road/San Felipe Road
9. Fowler Road/San Felipe Road
10. San Felipe Road/Yerba Buena Avenue
11. Aborn Road/White Road/San Felipe Road
12. Aborn Road/Nieman Boulevard
13. East Capitol Expressway/Aborn Road\*
14. East Capitol Expressway/Silver Creek Road\*

\* Designated CMP intersection.

### **Freeway Segments**

The analysis also evaluated the operations of the following key freeway segments:

1. US 101, between Silver Creek Valley Road and Hellyer Avenue
2. US 101, between Hellyer Avenue and Yerba Buena Road
3. US 101, between Yerba Buena Road and East Capitol Expressway
4. US 101, between East Capitol Expressway and Tully Road

Freeway segments were evaluated under Existing and Existing Plus Project Conditions following VTA and Caltrans guidelines.

### **INTERSECTION ANALYSIS SCENARIOS**

The operations of the key intersections were evaluated during the weekday morning (AM) and afternoon (PM) peak hours for the following four scenarios:

- Scenario 1:** *Existing Conditions* – Existing volumes obtained from counts.
- Scenario 2:** *Existing Plus Project Conditions* – Scenario 1 volumes plus traffic generated by the proposed Facilities Master Plan.
- Scenario 3:** *Cumulative No Project Conditions* – Existing volumes (Scenario 1) plus traffic from approved but not yet constructed and pending developments in the area.
- Scenario 4:** *Cumulative Plus Project Conditions* – Scenario 3 volumes plus traffic generated by the proposed Facilities Master Plan.

### **TRAFFIC ANALYSIS METHODS**

The operations of roadway facilities are described with the term level of service (LOS). LOS is a qualitative description of traffic flow based on such factors as speed, travel time, delay, and freedom to maneuver. Six levels are defined from LOS A, with the best operating conditions, to LOS F, with the worst operating conditions. LOS E represents “at-capacity” operations. Operations are designated as LOS F when volumes exceed capacity, resulting in stop-and-go conditions.

The City of San Jose has established a minimum acceptable operating level of LOS D for all intersections. Congestion Management Program (CMP) designated intersections under the jurisdiction of the City will be held to the LOS D standard. The minimum acceptable level for CMP-monitored intersections not under the City’s jurisdiction is LOS E.

#### **Signalized Intersections**

The level of service methodology approved by the City of San Jose, VTA, and Caltrans analyzes a signalized intersection’s operation based on average control vehicular delay using the method described in Chapter 16 of the *2000 Highway Capacity Manual (HCM)* by the Transportation Research Board, with adjusted saturation flow rates to reflect Santa Clara County conditions. Control delay includes initial deceleration delay, queue move-up time, stopped delay, and final acceleration delay. The average control delay for signalized intersections is calculated using TRAFFIX analysis software and correlated to a LOS designation as shown in **Table 1**.

**TABLE 1  
SIGNALIZED INTERSECTION LEVEL OF SERVICE DEFINITIONS  
USING AVERAGE CONTROL VEHICULAR DELAY**

Level of Service	Description	Average Control Delay Per Vehicle (Seconds)
A	Operations with very low delay occurring with favorable progression and/or short cycle lengths.	≤ 10.0
B+ B B-	Operations with low delay occurring with good progression and/or short cycle lengths.	10.1 to 12.0 12.1 to 18.0 18.1 to 20.0
C+ C C-	Operations with average delays resulting from fair progression and/or longer cycle lengths. Individual cycle failures begin to appear.	20.1 to 23.0 23.1 to 32.0 32.1 to 35.0
D+ D D-	Operations with longer delays due to a combination of unfavorable progression, long cycle lengths, and high V/C ratios. Many vehicles stop and individual cycle failures are noticeable.	35.1 to 39.0 39.1 to 51.0 51.1 to 55.0
E+ E E-	Operations with high delay values indicating poor progression, long cycle lengths, and high V/C ratios. Individual cycle failures are frequent occurrences.	55.1 to 60.0 60.1 to 75.0 75.1 to 80.0
F	Operations with delays unacceptable to most drivers occurring due to over-saturation, poor progression, or very long cycle lengths.	> 80.0

Source: *Traffic Level of Service Analysis Guidelines*, VTA Congestion Management Program, June 2003; *Highway Capacity Manual*, Transportation Research Board, 2000.

### Freeway Segments

Freeway segments are evaluated using VTA's analysis procedure, which is based on the density of the traffic flow using methods described in the *2000 HCM*. Density is expressed in passenger cars per mile per lane. The Congestion Management Program range of densities for freeway segment level of service is shown in **Table 2**. The LOS standard for the freeway segments is LOS E.

**TABLE 2  
FREEWAY SEGMENT LEVEL OF SERVICE DEFINITIONS**

Level of Service	Density (passenger cars per mile per lane)
A	≤ 11
B	11.1 to 18.0
C	18.1 to 26.0
D	26.1 to 46.0
E	46.1 to 58.0
F	> 58.0

Sources: *Traffic Level of Service Analysis Guidelines*, VTA Congestion Management Program, June 2003; *Highway Capacity Manual*, Transportation Research Board, 2000.

## **REPORT ORGANIZATION**

The remainder of this report is divided into three chapters. The existing transportation system serving the Project and the current operating conditions of key intersections and freeway segments are described in Chapter 2. Chapter 3 describes Existing Plus Project Conditions, including the method used to estimate the amount of traffic added to the surrounding roadways by the proposed Project and their impacts on the transportation system. A discussion of site access and on-site circulation is contained in Chapter 3. Cumulative Conditions are described in Chapter 4.



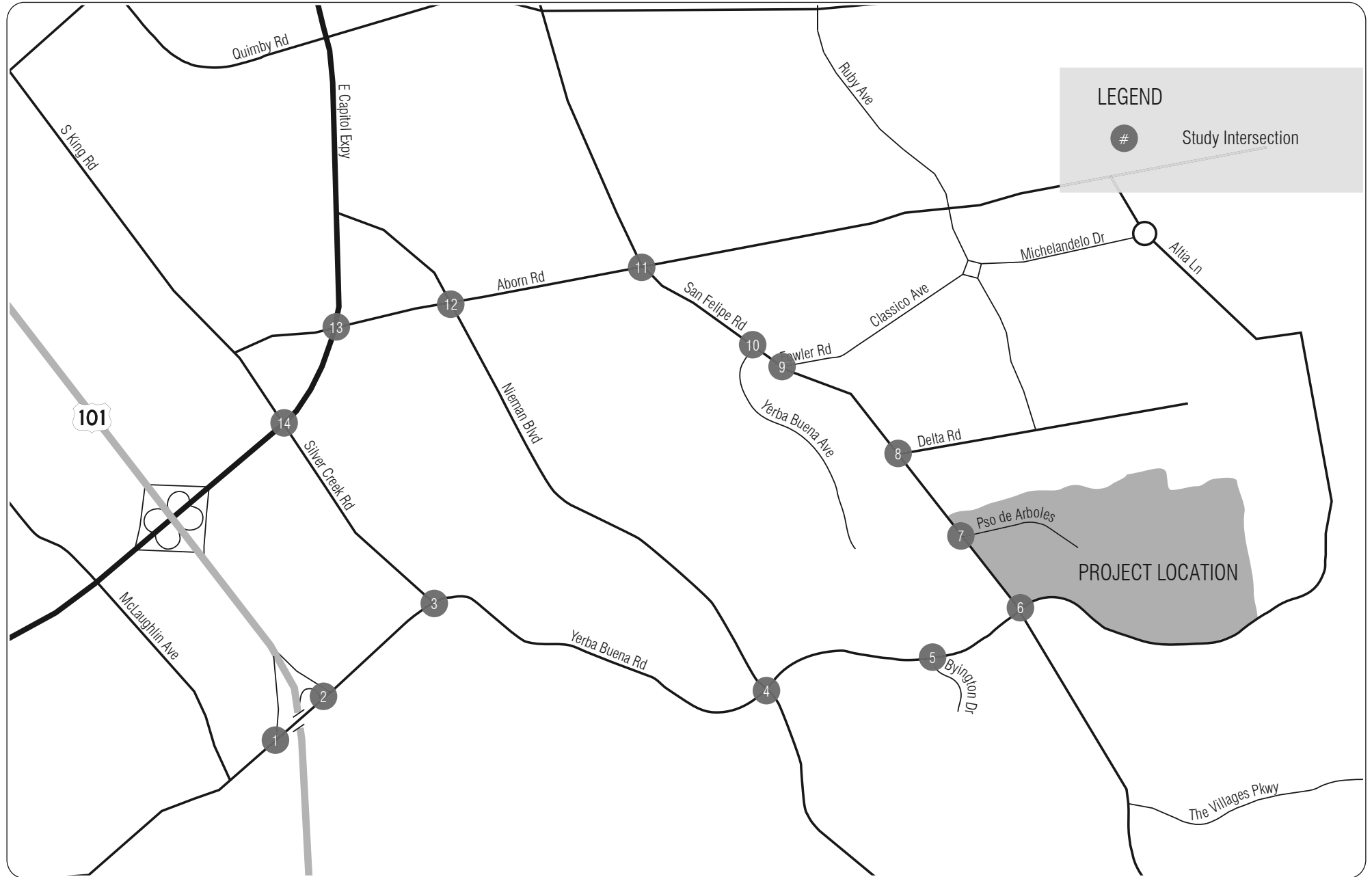



## 2. EXISTING CONDITIONS

This chapter describes existing transportation network in the project site vicinity, including roadway facilities, pedestrian and bicycle facilities, transit service, traffic volumes, and intersection operations.

### EXISTING ROADWAY NETWORK

This section describes the existing roadway network near the EVC campus, which was previously illustrated on Figure 1.

#### **Regional Access**

*Highway 101 (US 101)* is a north-south freeway west of the EVC campus extending north to downtown San Jose and San Francisco, and south towards Gilroy. The freeway provides three mixed-flow lanes and one carpool lane in each direction near the EVC campus. The carpool lane is open to mixed-flow traffic outside of the peak periods. The campus is accessible via ramps at Yerba Buena Boulevard.

*East Capitol Expressway* is a radial arterial roadway northwest of the EVC campus that connects State Route (SR) 87, US 101 and Interstate (I) 680. The roadway bypasses the SR 87 / I-280 and US 101 / I-680 interchanges to the south. In the vicinity of the EVC campus, East Capitol Expressway has four travel lanes in each direction.

#### **Local Access**

*Yerba Buena Road* is an east-west, four-lane arterial roadway bordering the southern edge of the EVC campus. Yerba Buena Road provides the primary connection to US 101 to the west. It also extends to the northeast where it terminates at Fowler Road.

*San Felipe Road* is a north-south, four-lane arterial roadway bordering the western edge of the EVC campus. It connects to Aborn Road to the north. North of Aborn Road, San Felipe Road becomes South White Road. To the south, the roadway extends beyond the City limit.

*Aborn Road* is an east-west, two- to six-lane arterial roadway that runs parallel to Yerba Buena Road north of the EVC campus. Aborn Road provides six lanes between East Capitol Expressway and Mosher Drive, which is approximately 1.5 miles east of San Felipe Road.

Internal circulation on the EVC campus is facilitated by Paseo de Arboles and Valle del Laeo and within campus parking lots. There are no roadways that connect the west side to the east side of the campus.

### EXISTING PEDESTRIAN AND BICYCLE FACILITIES

#### **Pedestrian Facilities**

Pedestrian facilities are comprised of sidewalks, crosswalks, pedestrian signals, and off-street paths. Sidewalks in the study area are generally consistent and continuous along surrounding roadways on both sides of the street with the exception of the following locations:

- The south side of Yerba Buena Road east of San Felipe Road
- The west side of San Felipe Road is discontinuous in several locations to the north and south of Yerba Buena Road

Separated paths are provided along Paseo de Arboles from the EVC campus to San Felipe Road. Crosswalks and pedestrian signals are located at the signalized intersections within the study area. Existing pedestrian facilities are shown on **Figure 3**.

On-campus pedestrian facilities consist of paths connecting buildings to each other and to parking lots. Typically these paths on a campus provide for pedestrian connectivity and require bicyclists to walk their bicycles. All on-campus pedestrian circulation is provided by the use of pedestrian walkways/paths.

### ***Bicycle Facilities***

Bicycle facilities include the following:

- *Bike paths (Class I)* – Paved trails that are separated from roadways.
- *Bike lanes (Class II)* – Lanes on roadways designated for use by bicycles through striping, pavement legends, and signs.
- *Bike routes (Class III)* – Designated roadways for bicycle use by signs only; may or may not include additional pavement width for cyclists.

**Figure 3** presents existing bicycle facilities in the study area.

A Class I bicycle path is located along Evergreen Creek. Access to the trail is provided on the north side of the EVC campus and extends between San Felipe Road and Yerba Buena Road, although partially unpaved. Class II bicycle lanes are located in both directions on San Felipe Road north of Yerba Buena Road, on Yerba Buena Road between the EVC campus and Silver Creek Road, and on Aborn Road between East Capitol Expressway and Ruby Avenue providing key connections to surrounding land uses.

The City of San Jose Bicycle Plan identifies future bike lanes on many local roadways and a Class I bike path that would run parallel to San Felipe Road.

No bicycle facilities such as bike paths or lanes exist on campus. Typical to other college and university campuses, bicycle use is prohibited in the center of campus where “bicycles... may not be ridden on campus sidewalks.”<sup>1</sup> Bicycle parking is provided at a variety of locations on the EVC campus via bike racks.

<sup>1</sup> San Jose/Evergreen Community College District Parking and Traffic Regulations Section 3.00  
[http://www.sjcccd.edu/DistrictPolice/Documents/ParkingTrafficRegulations\\_2012.pdf](http://www.sjcccd.edu/DistrictPolice/Documents/ParkingTrafficRegulations_2012.pdf)



## EXISTING TRANSIT SERVICE

Santa Clara Valley Transportation Authority (VTA) provides fixed-route bus service on 72 local routes in Santa Clara County, serving the City of San Jose. VTA also operates light rail service in Santa Clara County. **Figure 4** shows the existing transit facilities in the study area.

VTA bus stops for routes 31 and 39 provide transit service adjacent to EVC. The campus has minimal transit service.

Route 31 provides service between the Eastridge Transit Center and EVC. Service is provided weekdays between 6:00 am and 10:30 pm on approximately 30-minute headways. Weekend service is provided on both Saturday and Sunday between 9:00 am and 5:30 pm on 60-minute headways. Stops include EVC, the Aborn Road / South White Road intersection, the Silver Creek Road / East Capitol Expressway intersection, and the Eastridge Transit Center. These stops provide access to Silver Creek High School and Eastridge Shopping Center.

Route 39 does not provide a direct connection to EVC. A stop is located approximately three-quarters of a mile south at Hounds Estates / The Villages Parkway intersection. Pedestrian access through the adjacent neighborhood is provided directly across from Valle del Laeo. Service is provided weekdays between 6:30 am and 7:30 pm on headways between 30 minutes and 60 minutes. Weekend service is provided on both Saturday and Sunday between 6:45 am and 7:50 pm on similar headways. Stops include The Villages development, Ruby Avenue and Evergreen Village, the Quimby Road / Ruby Avenue intersection, and the Eastridge Transit Center. These stops provide access to the Evergreen Village Square, Evergreen Valley High School, Quimby Oaks Middle School, and Eastridge Shopping Center.

Ridership information for the two bus routes identified above are presented in **Table 3**.

TABLE 3 VTA RIDERSHIP AND CAPACITY AT THE MAXIMUM LOAD POINT – EXISTING CONDITIONS					
Route	Direction	Vehicle Type <sup>1</sup>	Maximum Passenger Load <sup>2</sup>	Peak Hour Capacity <sup>3</sup>	Capacity Utilization
AM Peak Hour					
31	Northbound	RBS	14	120	11%
31	Southbound	RBS	55	120	46%
39	Northbound	CBS	14	54	27%
39	Southbound	CBS	27	54	50%
PM Peak Hour					
31	Northbound	RBS	48	120	40%
31	Southbound	RBS	32	120	26%
39	Northbound	CBS	11	54	21%
39	Southbound	CBS	17	54	31%
Notes:					
1. RBS – Regular Bus Service; CBS – Community Bus Service					
2. Ridership and number of buses during the peak hour					
3. Total peak hour capacity in vehicles per hour					
Sources: VTA, 2011; Fehr & Peers, 2011					

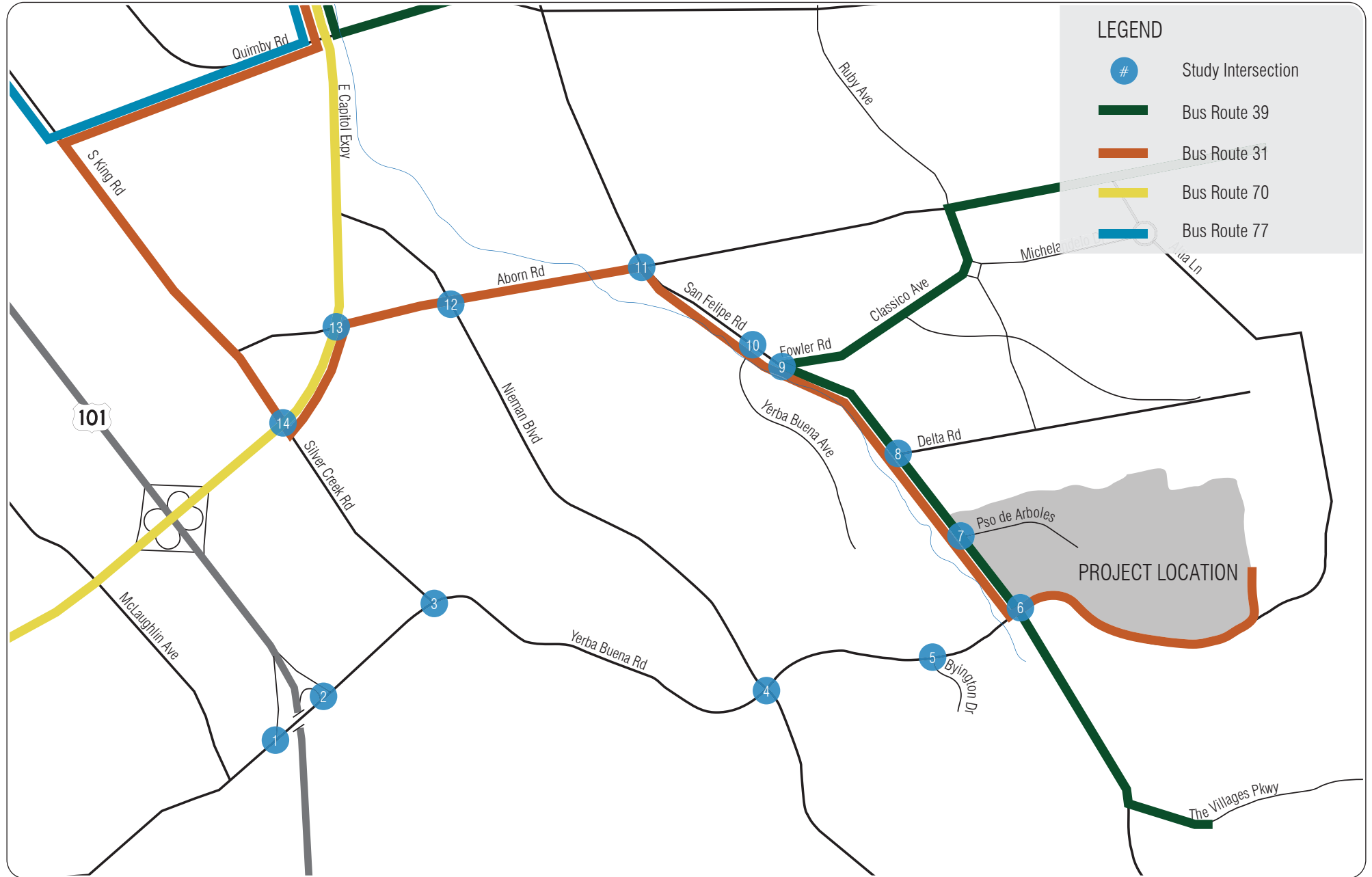

## EXISTING VOLUMES AND LANE CONFIGURATIONS

Study intersection operations were evaluated during the weekday AM and PM peak hours. Intersection operations were evaluated for the highest one-hour volume counted between 7:00 and 9:00 AM and between 4:00 and 6:00 PM. Intersection turning movement counts were conducted in September 2011 when classes at EVC were in session. The traffic counts are included in **Appendix A**.

**Figure 5** presents the existing AM and PM peak-hour turning movement volumes at the study intersections and the existing intersection lane configurations and traffic control devices.

### *Existing Intersection Levels of Service*

Existing operations were evaluated for the weekday AM and PM peak hours at the study intersections, as summarized in **Table 4**, based on the turning movement volumes, lane configurations and traffic control shown on Figure 5. All study intersections currently operate at acceptable levels of service according to the standards set forth by the City of San Jose, VTA, and Caltrans, with the potential exception of the East Capitol Expressway / Aborn Road intersection, which operates at LOS E during the PM peak hour. As this intersection is a CMP intersection, LOS E is considered acceptable according to the VTA, although unacceptable under City of San Jose standards. **Appendix B** contains the corresponding calculation sheets.



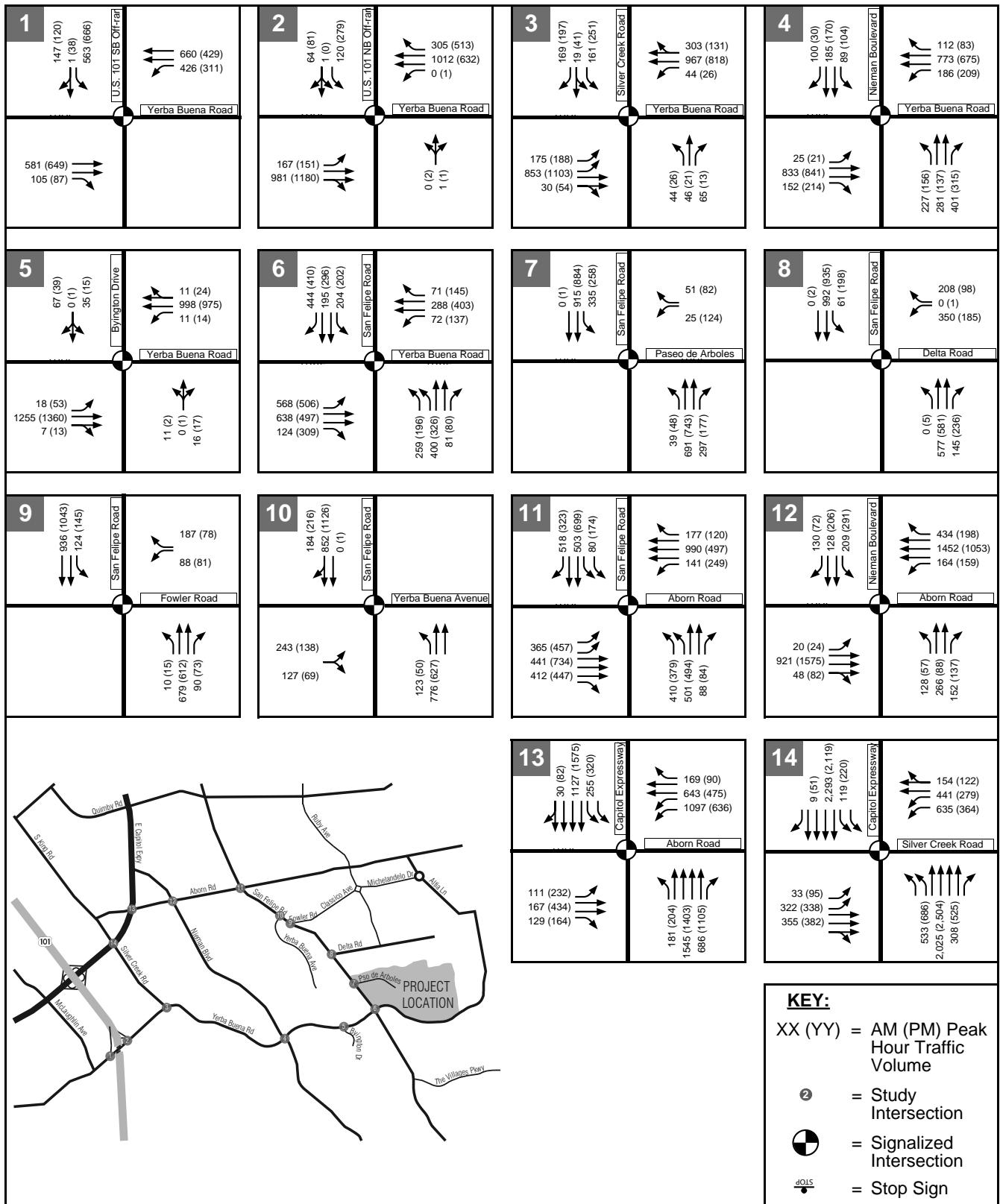

Evergreen Community College

**EXISTING LANE GEOMETRIES, TRAFFIC CONTROLS, AND PEAK HOUR INTERSECTION VOLUMES**

**FIGURE 5**

**TABLE 4  
EXISTING INTERSECTION LEVELS OF SERVICE**

Intersection	Traffic Control	Peak Hour	Count Date	Delay <sup>1</sup>	LOS <sup>2</sup>
1. US 101 SB Off-Ramp & Yerba Buena Road*	Signal	AM	9/2011	29.7	C
		PM	9/2011	30.6	C
2. US 101 NB Off-Ramp & Yerba Buena Road*	Signal	AM	9/2011	15.2	B
		PM	9/2011	16.6	B
3. Silver Creek Road & Yerba Buena Road	Signal	AM	9/2011	18.3	B-
		PM	9/2011	18.4	B-
4. Nieman Boulevard / Silver Creek Valley Road & Yerba Buena Road	Signal	AM	9/2011	27.5	C
		PM	9/2011	27.1	C
5. Byington Drive / Yerba Buena Avenue & Yerba Buena Road	Signal	AM	9/2011	9.6	A
		PM	9/2011	8.1	A
6. San Felipe Road & Yerba Buena Road	Signal	AM	9/2011	38.1	D+
		PM	9/2011	37.8	D+
7. Paseo de Arboles & San Felipe Road	Signal	AM	9/2011	15.1	B
		PM	9/2011	16.9	B
8. Delta Road & San Felipe Road	Signal	AM	9/2011	19.6	B-
		PM	9/2011	16.9	B
9. Fowler Road & San Felipe Road	Signal	AM	9/2011	15.3	B
		PM	9/2011	10.5	B+
10. San Felipe Road & Yerba Buena Avenue	Signal	AM	9/2011	20.8	C+
		PM	9/2011	19.6	B-
11. Aborn Road & White Road / San Felipe Road	Signal	AM	9/2011	48.2	D
		PM	9/2011	49.2	D
12. Aborn Road & Nieman Boulevard	Signal	AM	9/2011	39.1	D
		PM	9/2011	39.2	D
13. East Capitol Expressway & Aborn Road*	Signal	AM	9/2011	54.6	D-
		PM	9/2011	<b>67.2</b>	<b>E</b>
14. East Capitol Expressway & Silver Creek Road*	Signal	AM	9/2011	54.5	D-
		PM	9/2011	52.0	D-

Notes: **BOLD** = Unacceptable Operations

1 Whole intersection weighted average control delay expressed in seconds per vehicle calculated using methods described in the 2000 HCM, with adjusted saturation flow rates to reflect Santa Clara County Conditions.

2 LOS = Level of service. LOS calculations conducted using the TRAFFIX level of service analysis software package.

\* CMP intersection.

Source: Fehr & Peers, September 2011.

## EXISTING FREEWAY SEGMENT LEVELS OF SERVICE

Freeway segment densities reported in VTA's 2007 *Monitoring and Conformance Report* were used to calculate the levels of service for the key freeway segments during the AM and PM peak hours. The results of the LOS analysis for Existing Conditions are presented in **Table 5**.

The following segments of mixed-flow lanes are operating at unacceptable levels (LOS F) according to VTA and Caltrans standards:

- Northbound US 101, between Hellyer Avenue and Yerba Buena Road (AM peak)
- Northbound US 101, between Yerba Buena Road and East Capitol Expressway (AM peak)
- Northbound US 101, between East Capitol Expressway and Tully Road (AM peak)
- Southbound US 101, between Tully Road and East Capitol Expressway (PM peak)

The following segments of high-occupancy lanes are operating at unacceptable levels (LOS F):

- Northbound US 101, between East Capitol Expressway and Tully Road (AM peak)

Freeway	From	To	Number of Lanes		Peak Hour <sup>1</sup>	Density <sup>1</sup>		Level of Service	
			Mixed	HOV		Mixed	HOV	Mixed	HOV
US 101 Northbound	Silver Creek Valley Road	Hellyer Avenue	3	1	AM PM	48 27	27 8	E D	D A
	Hellyer Avenue	Yerba Buena Road	3	1	AM PM	<b>60</b> 30	25 8	<b>F</b> D	C A
	Yerba Buena Road	East Capitol Expressway	3	1	AM PM	<b>73</b> 20	22 8	<b>F</b> C	C A
	East Capitol Expressway	Tully Road	3	1	AM PM	<b>66</b> 31	<b>60</b> 12	<b>F</b> D	<b>F</b> B
US 101 Southbound	Tully Road	East Capitol Expressway	3	1	AM PM	27 <b>63</b>	9 24	D <b>F</b>	A C
	East Capitol Expressway	Yerba Buena Road	3	1	AM PM	23 23	8 16	C C	A B
	Yerba Buena Road	Hellyer Avenue	3	1	AM PM	31 30	14 24	D D	B C
	Hellyer Avenue	Silver Creek Valley Road	3	1	AM PM	23 23	7 11	C C	A A

Note: **BOLD** = Unacceptable Operations  
 1 Measured in passenger cars per mile per lane.  
 Source: 2010 *Monitoring and Conformance Report*, VTA, May 2011.

### 3. EXISTING PLUS PROJECT CONDITIONS

This chapter identifies the potential off-site impacts of the proposed Project. First, the method used to estimate the amount of traffic generated by the increased number of enrolled students is described. Then, the results of the level of service calculations for Existing Plus Project Conditions are presented. Existing Plus Project Conditions are defined as Existing Conditions plus traffic generated by the Project. Existing Plus Project impacts are then identified by comparing the level of service results under Existing Plus Project Conditions to those under Existing Conditions. Site access, on-site circulation, parking, and pedestrian, bicycle, and transit impacts are also addressed in this chapter.

#### PROJECT TRAFFIC ESTIMATES

The amount of traffic added to the roadway system by the proposed EVC Facilities Master Plan is estimated using a three-step process:

1. **Trip Generation** – The *amount* of vehicle traffic entering and exiting the Project site was estimated, taking into consideration travel by walking, biking and busing to the campus.
2. **Trip Distribution** – The *direction* trips use to approach and depart the site was projected.
3. **Trip Assignment** – Trips were then *assigned* to specific roadway segments and intersection turning movements.

This process for the proposed Project is described in the following sections.

#### **Trip Generation**

##### Additional Students

The amount of traffic generated by the additional students was estimated by applying rates derived from driveway counts of the San Jose City College campus conducted in September 2007. It was assumed that driver behavior between the two campuses was similar on a per student basis. The rates were derived from student enrollment at the time of the survey, which was approximately 12,000 students. Trip generation rates per student were calculated for the AM and PM peak hours, as shown in **Table 6**. The Project would increase the student population by approximately 2,863 students, resulting in an approximately 3,980 new daily trips, 315 new AM peak-hour trips (251 inbound and 64 outbound) and 381 new PM peak-hour trips (249 inbound and 132 outbound).

##### *Comparison of Trip Generation Rates to ITE Rates*

The Institute of Transportation Engineers *Trip Generation*, 8th Edition has trip generation rates of 0.12 trips per student for both the AM and PM peak hours. These are about 10 percent different than the rates observed in the surveys of the SJCC campus. However, the rates are based on a limited number of studies (5 trip generation surveys) and may not reflect a similar environment of the San Jose area. Two of the five studies identified transit centers within close proximity of the studied campuses. Transit use could affect the trip generation rates at those locations. The SJCC-specific trip generation rates were used in analyzing the traffic generation of the new students to reflect a locally validated trip generation rate.

**TABLE 6  
PROJECT TRIP GENERATION RATES AND ESTIMATES**

Land Use	Size	Daily	AM			PM		
			In	Out	Total	In	Out	Total
<b>Trip Rates<sup>1</sup></b>								
San Jose City College Students	Per student	1.39	80%	20%	0.11	65%	35%	0.13
<b>Trip Estimates</b>								
Evergreen Valley College Additional students	Additional 2,863 Students <sup>3</sup>	3,980	251	64	315	249	132	381
Note:								
1 Rates used based on data collected at San Jose City College driveways.								
Source: <i>Fehr &amp; Peers</i> , 2011.								

### ***Trip Distribution***

The directions of approach and departure for Project traffic were estimated based on the existing travel patterns in the area and the relative locations of complementary land uses including residential and commercial uses. In addition, population density data from the 2000 Census Transportation Planning Packet (CTPP) was used. The major directions of approach and departure from the trip distribution pattern for the project, and are illustrated on **Figure 6**. The trip distribution is generally consistent with the analysis presented in the EVC Facilities Master Plan EIR, May 2001.

### ***Trip Assignment***

The trips generated by the Project were assigned to the roadway system based on the directions of approach and departure discussed above. **Figure 7** shows the AM and PM peak-hour project trips assigned to each turning movement at the study intersections. Project trips were added to Existing Conditions traffic volumes to establish intersection volumes for Existing Plus Project Conditions, as shown on **Figure 8**.

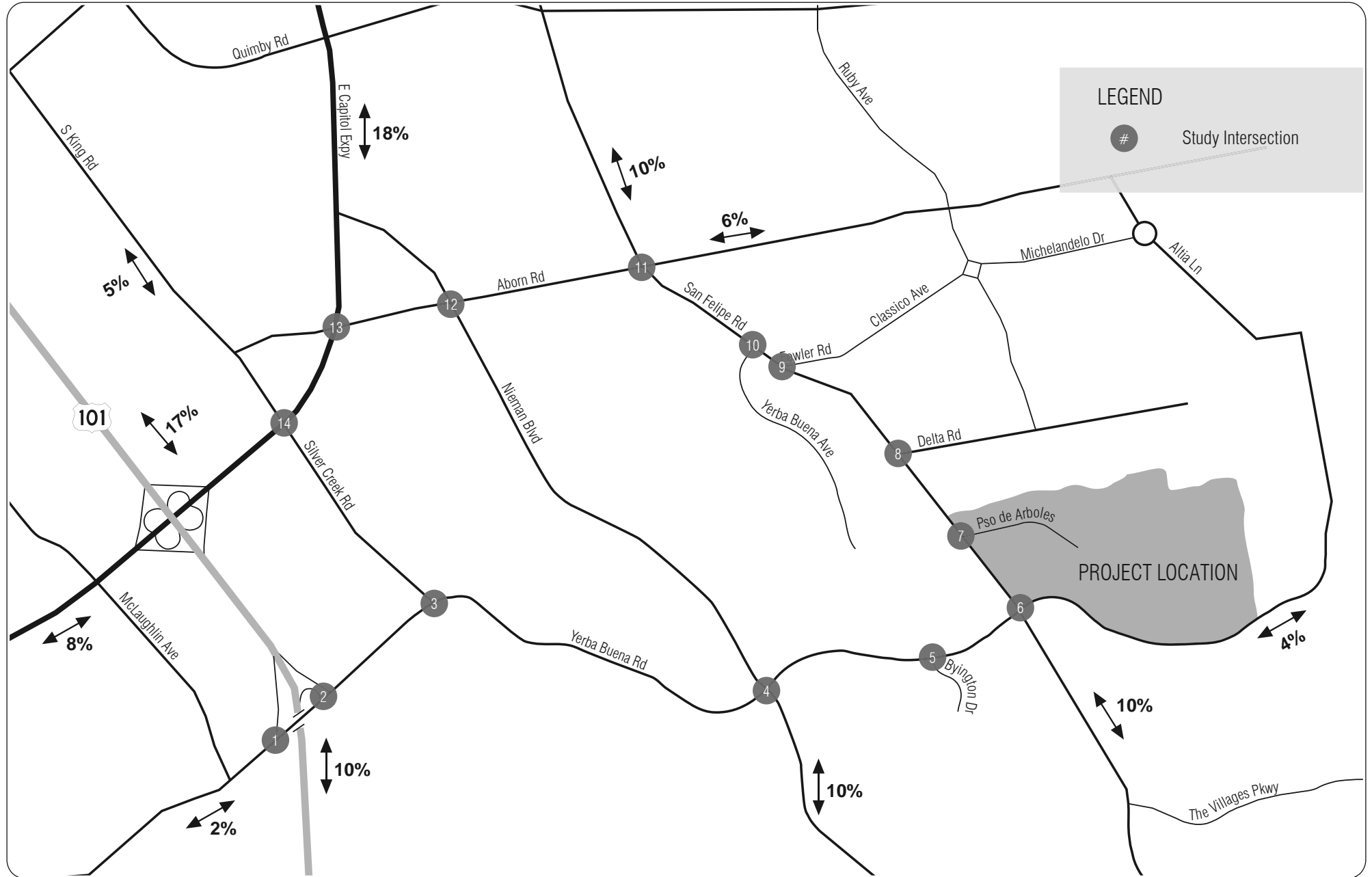



Evergreen Community College

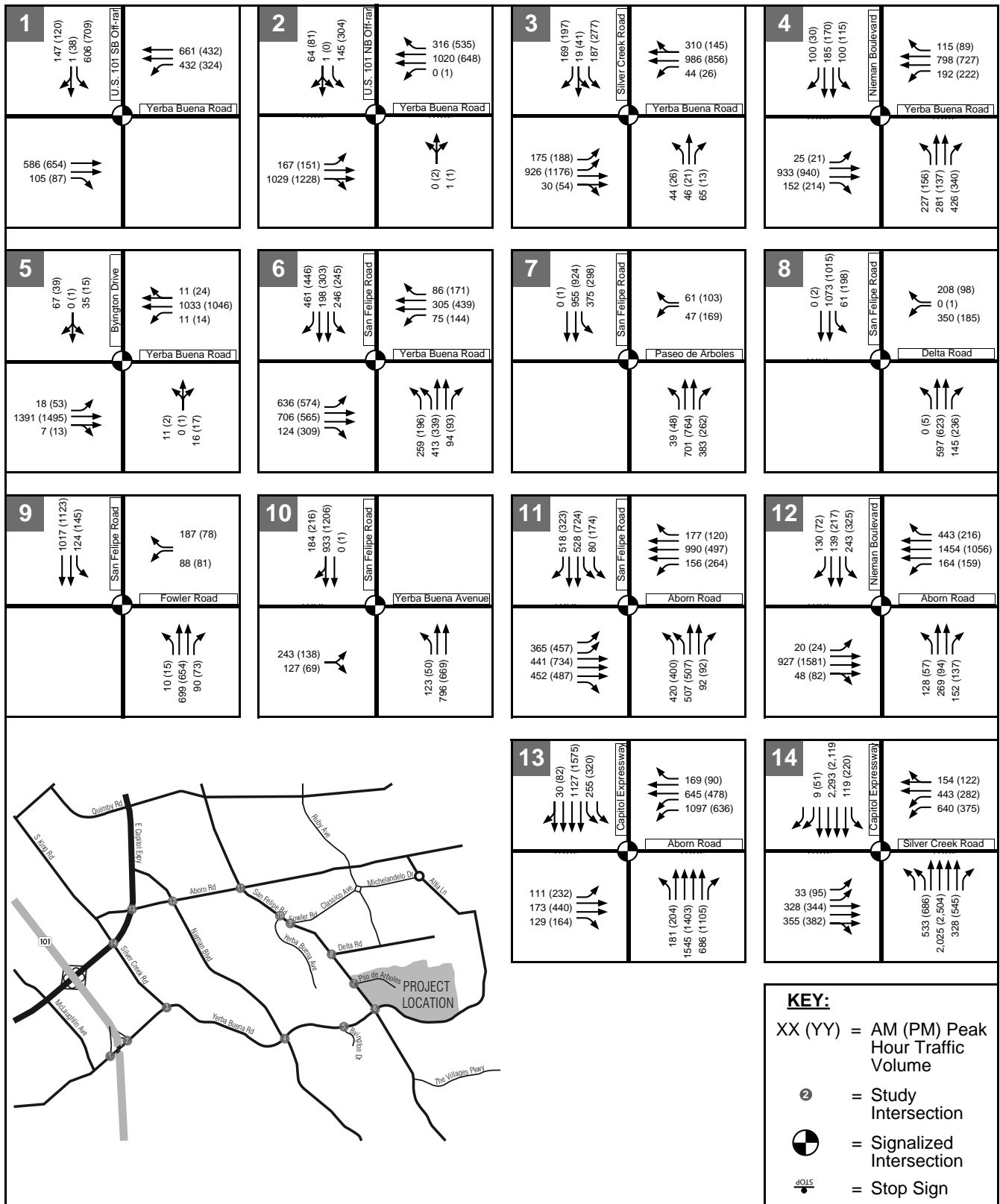

Evergreen Community College

**EXISTING PLUS PROJECT LANE GEOMETRIES, TRAFFIC CONTROLS, AND PEAK-HOUR INTERSECTION VOLUMES**

**FIGURE 8**



## EXISTING PLUS PROJECT INTERSECTION LEVELS OF SERVICE

Level of service calculations were conducted to evaluate intersection operations under Existing Plus Project Conditions. The results of the LOS analysis are summarized in **Table 7**. The changes in overall intersection delay due to the addition of project traffic are also shown in this table. In a few instances, slight improvements in delay are reported. This is due to the methodology the program uses to allocate green time to the various turning movements based on changes in the traffic volumes on individual approaches.

The results for Existing Conditions are included for comparison purposes, along with the projected increases in critical delay and critical volume-to-capacity (V/C) ratios for intersections that would operate unacceptably. Critical delay represents the delay associated with the critical movements of the intersection, or the movements that require the most "green time" and have the greatest effect on overall intersection operations. The changes in critical delay and critical V/C ratio between Existing and Existing Plus Project Conditions are used to identify significant impacts.

All intersections continue to operate acceptably in both peak periods under City of San Jose, VTA, and Caltrans standards except for the East Capitol Expressway / Aborn Road intersection, which operates at LOS E in the PM peak hour with or without the project.

Intersection	Peak Hour	Existing		Existing Plus Project			
		Delay <sup>1</sup>	LOS <sup>2</sup>	Delay <sup>1</sup>	LOS <sup>2</sup>	Δ in Crit. V/C <sup>3</sup>	Δ in Crit. Delay <sup>4</sup>
1. US 101 SB Off-Ramp & Yerba Buena Road*	AM	29.7	C	30.6	C	N/A	N/A
	PM	30.6	C	31.6	C	N/A	N/A
2. US 101 NB Off-Ramp & Yerba Buena Road*	AM	15.2	B	15.8	B	N/A	N/A
	PM	16.6	B	18.1	B-	N/A	N/A
3. Silver Creek Road & Yerba Buena Road	AM	18.3	B-	18.3	B-	N/A	N/A
	PM	18.4	B-	18.4	B-	N/A	N/A
4. Nieman Boulevard / Silver Creek Valley Road & Yerba Buena Road	AM	27.5	C	28.0	C	N/A	N/A
	PM	27.1	C	27.5	C	N/A	N/A
5. Byington Drive / Yerba Buena Avenue & Yerba Buena Road	AM	9.6	A	9.3	A	N/A	N/A
	PM	8.1	A	8.0	A	N/A	N/A
6. San Felipe Road & Yerba Buena Road	AM	38.1	D+	39.7	D	N/A	N/A
	PM	37.8	D+	39.7	D	N/A	N/A
7. Paseo de Arboles & San Felipe Road	AM	15.1	B	14.5	B	N/A	N/A
	PM	16.9	B	19.0	B-	N/A	N/A
8. Delta Road & San Felipe Road	AM	19.6	B-	19.1	B-	N/A	N/A
	PM	16.9	B	16.2	B	N/A	N/A
9. Fowler Road & San Felipe Road	AM	15.3	B	14.7	B	N/A	N/A
	PM	10.5	B+	10.0	B+	N/A	N/A
10. San Felipe Road & Yerba Buena Avenue	AM	20.8	C+	20.3	C+	N/A	N/A
	PM	19.6	B-	19.6	B-	N/A	N/A
11. Aborn Road & White Road / San Felipe Road	AM	48.2	D	48.7	D	N/A	N/A
	PM	49.2	D	50.0	D	N/A	N/A

**TABLE 7  
EXISTING AND EXISTING PLUS PROJECT INTERSECTION LEVELS OF SERVICE**

Intersection	Peak Hour	Existing		Existing Plus Project			
		Delay <sup>1</sup>	LOS <sup>2</sup>	Delay <sup>1</sup>	LOS <sup>2</sup>	Δ in Crit. V/C <sup>3</sup>	Δ in Crit. Delay <sup>4</sup>
12. Aborn Road & Nieman Boulevard	AM	39.1	D	40.6	D	N/A	N/A
	PM	39.2	D	40.5	D	N/A	N/A
13. East Capitol Expressway & Aborn Road*	AM	54.6	D-	54.6	D-	N/A	N/A
	PM	<b>67.2</b>	<b>E</b>	<b>67.4</b>	<b>E</b>	0	0
14. East Capitol Expressway & Silver Creek Road*	AM	54.5	D-	54.6	D-	N/A	N/A
	PM	52.0	D-	52.3	D-	N/A	N/A

Notes: **BOLD** = Unacceptable Operations

1 Whole intersection weighted average control delay expressed in seconds per vehicle calculated using methods described in the 2000 HCM, with adjusted saturation flow rates to reflect Santa Clara County Conditions. Total control delay for the worst movement is presented for side-street stop-controlled intersections. Delay for the worst approach is reported for Unsignalized intersections.

2 LOS = Level of service. LOS calculations conducted using the TRAFFIX level of service analysis software package.

3 Change in the critical volume-to-capacity ratio (V/C) between Existing and Existing Plus Project Conditions.

4 Change in critical movement delay between Existing and Existing Plus Project Conditions.

\* CMP intersection.

N/A = not applicable

**Bold** type indicates a project impact as defined by City standards.

Source: *Fehr & Peers*, September 2011.

## INTERSECTION IMPACT CRITERIA

The impacts of the project were evaluated by comparing the results of the level of service calculations under Existing Plus Project Conditions to the results under Existing Conditions.

### City of San Jose

Significant impacts at signalized San Jose intersections occur when project traffic causes one of the following:

- Operations degrade from an acceptable level (LOS D or better) under Existing Conditions to an unacceptable level (LOS E or F) under Existing Plus Project Conditions.
- Unacceptable operations (LOS E or F) are exacerbated by increasing the critical delay by more than 4 seconds and increasing the volume-to-capacity (V/C) ratio by 0.01 or more.
- The V/C ratio increases by 0.01 or more at an intersection with unacceptable operations (LOS E or F) when the change in critical delay is negative (i.e., decreases). This can occur if the critical movements change.

### **Valley Transportation Authority**

Significant impacts at CMP intersections occur when project traffic causes one of the following:

- Operations degrade from an acceptable level (LOS E or better) under Existing Conditions to an unacceptable level (LOS F) under Existing Plus Project Conditions.
- LOS F operations are exacerbated by increasing the critical delay by more than 4 seconds and increasing the volume-to-capacity (V/C) ratio by 0.01 or more.
- The V/C ratio increases by 0.01 or more at an intersection with LOS F operations when the change in critical delay is negative (i.e., decreases). This can occur if the critical movements change.

### **INTERSECTION IMPACTS**

#### ***East Capitol Expressway & Aborn Road***

During the PM peak hour, the East Capitol Expressway / Aborn Road intersection operates at an unacceptable LOS E under Existing. The addition of traffic from the proposed Project does not increase the critical movement V/C ratio, and intersection delay remains unchanged, this is not a significant impact under the City of San Jose significance standards. Under VTA criteria, the intersection operates at an acceptable service level without and with the Project. Therefore, the Project impact to this intersection is considered **less-than-significant**.

### **EXISTING PLUS PROJECT FREEWAY SEGMENT LEVELS OF SERVICE**

CMP guidelines require that freeway segments to which a proposed development is projected to add trips equal to or greater than one percent of the freeway segment's capacity must be evaluated. Segments of US 101 were reviewed to determine if a significant amount of project traffic would be added to its freeway segments.

Capacities of 2,300 vehicles per hour per lane (vphpl) for freeway segments with six or more lanes were used in the freeway analysis. A capacity of 1,800 vphpl was used for high occupancy vehicle (HOV) lanes. For this analysis, it was assumed that the project trips using HOV lanes would be similar in proportion to existing use of HOV lanes. **Table 8** presents the capacities of each freeway segment and the estimated number of trips added to each segment by the proposed project.

**TABLE 8  
EXISTING PLUS PROJECT FREEWAY SEGMENT LEVELS OF SERVICE**

Freeway	From	To	Peak Hour	Mixed Flow				HOV			
				Project Trips	Density <sup>1</sup>	LOS <sup>2</sup>	% Impact <sup>3</sup>	Project Trips	Density <sup>1</sup>	LOS <sup>2</sup>	% Impact <sup>3</sup>
US 101 Northbound	Silver Creek Valley Road	Hellyer Avenue	AM	21	48	E	0.31%	4	27	D	0.23%
			PM	23	27	D	0.33%	2	8	A	0.14%
	Hellyer Avenue	Yerba Buena Road	AM	21	<b>60</b>	<b>F</b>	0.31%	4	25	C	0.23%
			PM	23	30	D	0.33%	2	8	A	0.13%
Yerba Buena Road	East Capitol Expressway	AM	9	<b>73</b>	<b>F</b>	0.14%	2	22	C	0.10%	
		PM	19	20	C	0.28%	19	8	A	0.17%	
East Capitol Expressway	Tully Road	AM	9	<b>66</b>	<b>F</b>	0.14%	2	<b>60</b>	<b>F</b>	0.10%	
		PM	19	31	D	0.28%	3	12	B	0.16%	
US 101 Southbound	Tully Road	East Capitol Expressway	AM	39	27	D	0.56%	4	9	A	0.27%
			PM	37	<b>63</b>	<b>F</b>	0.53%	6	24	C	0.39%
	East Capitol Expressway	Yerba Buena Road	AM	38	23	C	0.56%	5	8	A	0.28%
			PM	37	23	C	0.53%	6	16	B	0.39%
Yerba Buena Road	Hellyer Avenue	AM	5	31	D	0.08%	1	14	B	0.05%	
		PM	11	30	D	0.16%	2	24	C	0.12%	
Hellyer Avenue	Silver Creek Valley Road	AM	5	23	C	0.08%	1	7	A	0.03%	
		PM	11	23	C	0.16%	2	11	B	0.11%	

Note: **BOLD** = Unacceptable Operations

1 Measured in passenger cars per mile per lane.

2 LOS = level of service.

3 Percent impact determined by dividing the number of project trips by the freeway segment's capacity.

**Bold** type indicates a project impact.

Source: 2010 Monitoring and Conformance Report, Fehr & Peers, September 2011

## FREEWAY IMPACTS

The impacts of the project were evaluated by comparing the results of the level of service calculations under Existing Plus Project Conditions to the results under Existing Conditions. Significant impacts to freeway segments occur when the addition of project traffic causes one of the following:

- A segment drops below its acceptable CMP operating standard (LOS E)
- Unacceptable operations (LOS F) are exacerbated by adding traffic equal to more than one percent of a segment's capacity

Based on the impact criteria listed above, the proposed project would have a *less-than-significant* impact on all freeway segments.

## PEDESTRIAN, BICYCLE, AND TRANSIT FACILITY IMPACTS

The Project would cause a significant impact to pedestrian, bicycle, and transit facilities and services if one of the following occurs:

- An element of the proposed Project conflicts with existing or planned pedestrian, bicycle, and transit facilities.
- The proposed Project creates hazardous conditions for pedestrians or bicyclists that currently do not exist.

The project may generate additional demand for pedestrian facilities. Existing sidewalks are provided adjacent to and in the vicinity of the site. Sidewalks and pedestrian connections link the EVC campus to adjacent neighborhoods and transit facilities. The existing pedestrian facilities are expected to accommodate the increased demand. The proposed project does not conflict with any existing or proposed pedestrian facilities and the proposed project does not create hazardous conditions for pedestrians. Therefore, a **less-than-significant impact** is expected for pedestrian facilities.

The project may generate additional demand for bicycle facilities. The proposed project does not conflict with any existing or proposed facilities and the proposed project does not create hazardous conditions for bicyclists. Therefore, a **less-than-significant impact** is expected for bicycle facilities.

The project may generate additional demand for transit service. The Evergreen campus is served by two bus routes. Approximately four buses serve EVC during each peak hour. The existing transit service is expected to accommodate the possible increased demand and the proposed project does not conflict with any existing or proposed transit facilities. Therefore, a **less-than-significant impact** is anticipated for transit service.

## **SITE ACCESS AND ON-SITE CIRCULATION**

### **Site Access**

The EVC campus can currently be accessed from locations along San Felipe Road and Yerba Buena Road. Site access is considered adequate for the volume of traffic generated by the site. Paseo de Arboles would be maintained as the primary access to San Felipe Road and would continue to be controlled by a signalized intersection at San Felipe Road. Valle del Laeo, which currently provides access to Yerba Buena Road, will be converted to a pedestrian pathway. However, several new vehicular access points would be constructed along Yerba Buena Road. The access points would have little conflicting traffic and would be stop-controlled intersections. Based on the trip generation estimates, forecasted demand would be adequately served by these access points. Driveway spacing and sight distance at the new driveways would be adequate.

### **On-Site Circulation**

On-site circulation would be provided by internal roadways and driveways. These facilities would connect the various parking lots to each other. While a connection is currently provided around the perimeter of the campus, it is not designed as a formal roadway. The Facilities Master Plan identifies a loop road that connects Paseo de Arboles and the west side of the campus to the new access on the east side of campus. The inner core of campus would provide a series of interconnected pedestrian pathways, including a central pedestrian promenade that connects the west plaza and east plaza.

Generally, bicycles are not allowed to be ridden through the campus core. The site plan shows ample bicycle parking along the periphery of the campus core adjacent to campus buildings.

## **PARKING**

### **Parking Demand Due to 2,863 New Students**

The existing parking facilities on the EVC campus consist of several paved surface lots. The parking facilities are designated for specific users (student, staff, etc.).

Based on the parking study performed for the EVC Facilities Master Plan in 2001, an acceptable parking supply for the community college is between 4 and 5 students per parking space. The existing supply is approximately 4.7 students per parking space. According to EVC staff, the campus is adequately parked for the current enrollment. Due to construction of new buildings in the Facilities Master Plan, approximately 130 existing parking spaces would be removed (according to the Overlay of 2025 Facilities Master Plan on Existing Conditions by HMC Architects dated August 8, 2011). However, during Phase III of the Facilities Master Plan, the campus would build a 1,700 space parking structure. This is a net new increase of approximately 1,570. This provides a parking space for every two additional students, which will provide additional spaces beyond the growth anticipated by the college. This additional parking would support special event parking demand and other non-recurring demands. Parking demand is largely dependent upon enrollment, class schedule, and parking costs. It is not expected that the additional parking would induce demand beyond forecasted enrollment levels.

The proposed Project would result in a **potentially significant impact** if a construction management and phasing plan is not developed to ensure adequate parking is provided throughout the implementation of the facilities master plan.

*Mitigation Measure:* Develop a Construction Management Plan and Project Phasing.

With implementation of this mitigation measure, adequate parking for levels of enrollment during different phases of construction can be secured. Temporary parking or travel demand management may be acceptable tools used to manage parking demands. With the execution of this mitigation measure, the impact to parking would be reduced to a **less-than-significant impact**.

## 4. CUMULATIVE CONDITIONS

This chapter presents an analysis of Cumulative Conditions without and with the proposed Project. Cumulative No Project Conditions are defined as existing volumes plus traffic generated by approved but not yet constructed developments in the project study area, plus traffic generated by pending developments. Trips from the proposed Project (described in Chapter 3) are added to the Cumulative No Project Conditions to obtain Cumulative plus Project Conditions. This chapter describes the procedure used to determine the cumulative traffic volumes and the results of the level of service analysis for Cumulative Conditions. No freeway segments analysis was performed because VTA guidelines do not require an analysis of freeway operations under Cumulative Conditions. Project contributions to freeway segments under existing conditions were under one percent of segment capacity for both the mixed flow and HOV lanes.

### CUMULATIVE TRAFFIC ESTIMATES

Traffic volumes for Cumulative Conditions were estimated by adding traffic generated by approved and pending developments to existing traffic volumes. San Jose City staff provided an approved trip inventory (ATI) that accounts for projects that would potentially add traffic to the study intersections. The ATI is included in **Appendix C**. Traffic associated with pending projects, obtained from the City of San Jose were also included. **Figure 9** illustrates the traffic volumes at the key intersections under Cumulative No Project Conditions. The trips generated by the proposed project were added to the Cumulative No Project Condition volumes and are shown on **Figure 10**.

### CUMULATIVE ROADWAY IMPROVEMENTS

No roadway improvements were identified for inclusion under Cumulative Conditions.

### CUMULATIVE INTERSECTION LEVELS OF SERVICE

Level-of-service calculations were conducted for the study intersections to evaluate their operations under Cumulative No Project and Cumulative Plus Project Conditions. The results of the LOS analysis are presented in **Table 9**. **Appendix B** contains the corresponding calculation sheets.

Intersection	Peak Hour	Cumulative No Project		Cumulative Plus Project			
		Delay <sup>1</sup>	LOS <sup>2</sup>	Delay <sup>1</sup>	LOS <sup>2</sup>	Δ in Crit. V/C <sup>3</sup>	Δ in Crit. Delay <sup>4</sup>
1. US 101 SB Off-Ramp & Yerba Buena Road*	AM	92.9	F	101.8	F	+0.03	+8.9
	PM	139.5	F	151.1	F	+0.04	+11.6
2. US 101 NB Off-Ramp & Yerba Buena Road*	AM	14.2	B	14.6	B	N/A	N/A
	PM	25.5	C	26.8	C	N/A	N/A
3. Silver Creek Road & Yerba Buena Road	AM	17.7	B	18.3	B-	N/A	N/A
	PM	19.6	B-	20.7	C+	N/A	N/A
4. Nieman Boulevard / Silver Creek Valley Road & Yerba Buena Road	AM	28.3	C	31.1	C	N/A	N/A
	PM	31.7	C	37.8	D+	N/A	N/A
5. Byington Drive / Yerba Buena Avenue & Yerba Buena Road	AM	10.2	B+	10.7	B+	N/A	N/A
	PM	13.1	B	15.8	B	N/A	N/A

**TABLE 9  
CUMULATIVE AND CUMULATIVE PLUS PROJECT INTERSECTION LEVELS OF SERVICE**

6. San Felipe Road & Yerba Buena Road	AM	<b>67.2</b>	<b>E</b>	<b>77.9</b>	<b>E-</b>	+0.05	+10.7
	PM	<b>63.0</b>	<b>E</b>	<b>76.4</b>	<b>E-</b>	+0.06	+13.4
7. Paseo de Arboles & San Felipe Road	AM	13.4	B	13.5	B	N/A	N/A
	PM	13.5	B	15.8	B	N/A	N/A
8. Delta Road & San Felipe Road	AM	19.0	B-	18.6	B-	N/A	N/A
	PM	15.9	B	15.5	B	N/A	N/A
9. Fowler Road & San Felipe Road	AM	15.3	B	14.8	B	N/A	N/A
	PM	12.6	B	12.4	B	N/A	N/A
10. San Felipe Road & Yerba Buena Avenue	AM	20.1	C+	19.9	B-	N/A	N/A
	PM	13.3	B	13.2	B	N/A	N/A
11. Aborn Road & White Road / San Felipe Road	AM	54.6	D-	<b>55.5</b>	<b>E+</b>	<b>+0.01</b>	<b>+0.9</b>
	PM	<b>63.7</b>	<b>E</b>	<b>66.4</b>	<b>E</b>	<b>+0.03</b>	<b>+2.7</b>
12. Aborn Road & Nieman Boulevard	AM	36.3	D+	38.1	D+	N/A	N/A
	PM	46.6	D	49.7	D	N/A	N/A
13. East Capitol Expressway & Aborn Road*	AM	<b>181.8</b>	<b>F</b>	<b>182.0</b>	<b>F</b>	0.00	+0.2
	PM	<b>245.7</b>	<b>F</b>	<b>246.0</b>	<b>F</b>	0.00	+0.3
14. East Capitol Expressway & Silver Creek Road*	AM	<b>55.8</b>	<b>E+</b>	<b>55.9</b>	<b>E+</b>	0.00	+0.1
	PM	54.7	D-	<b>55.2</b>	<b>E+</b>	0.00	+0.5

Notes: **BOLD** = Unacceptable Operations; **SHADED** = significant impact

1 Whole intersection weighted average control delay expressed in seconds per vehicle calculated using methods described in the 2000 HCM, with adjusted saturation flow rates to reflect Santa Clara County Conditions. Total control delay for the worst movement is presented for side-street stop-controlled intersections. Delay for the worst approach is reported for Unsignalized intersections.

2 LOS = Level of service. LOS calculations conducted using the TRAFFIX level of service analysis software package.

3 Change in the critical volume-to-capacity ratio (V/C) between Cumulative and Cumulative Plus Project Conditions.

4 Change in critical movement delay between Cumulative and Cumulative Plus Project Conditions.

\* CMP intersection.

NA = not applicable

**Bold** type indicates a project impact as defined by City standards.

Source: *Fehr & Peers*, September 2011.

All intersections continue to operate acceptably in both peak periods under City of San Jose, VTA, and Caltrans standards except for the following intersections:

- US 101 SB Off-Ramp & Yerba Buena Road
- San Felipe Road & Yerba Buena Road
- Aborn Road & White Road / San Felipe Road
- East Capitol Expressway & Aborn Road
- East Capitol Expressway & Silver Creek Road



## PROJECT IMPACTS AND MITIGATION MEASURES

### ***US 101 SB Off-Ramp & Yerba Buena Road***

The proposed Project would result in a **significant impact** at the US 101 SB Off-Ramp / Yerba Buena Road signalized intersection in the cumulative condition. This intersection operates at an unacceptable LOS F under both the AM and PM peak hour conditions without the addition of project related trips. Project related increases would satisfy either the V/C or vehicle delay thresholds.

The US 101 SB Off-Ramp / Yerba Buena Road signalized intersection is physically constrained. To improve operating conditions to an acceptable level, widening of the intersection to provide additional capacity would be required. Substantial improvement could only be accomplished through extensive demolition and reconstruction of facilities and/or right-of-way acquisition; therefore, the measure was not further considered. Additionally, this intersection is a Caltrans facility and even if there were not physical constraints, implementation of improvements cannot be guaranteed by the City. Traffic impacts at this intersection under the Cumulative Plus Project conditions would remain **significant and unavoidable**.

### ***San Felipe Road & Yerba Buena Road***

The proposed Project would result in **significant impact** at the San Felipe Road / Yerba Buena Road signalized intersection in the cumulative condition. This intersection operates at an unacceptable LOS E under both the AM and PM peak hour conditions without the addition of project related trips. Project related increases would satisfy either the V/C or vehicle delay thresholds.

*Mitigation Measure:* Construct a second eastbound left-turn.

With implementation of this mitigation measure, operations at this intersection would improve to an acceptable LOS D in both the AM and PM peak hours. Installation of the second eastbound left-turn lane would require reconstruction of the center median and restriping of the eastbound lanes, but should not require additional right-of-way. Construction of the mitigation measure shall be the responsibility of the City. With the installation of this mitigation measure, the traffic impact at the San Felipe Road / Yerba Buena Road intersection would be reduced to a **less-than-significant impact**.

### ***Aborn Road & White Road / San Felipe Road***

The proposed Project would result in **significant impact** at the Aborn Road & White Road / San Felipe Road signalized intersection in the cumulative condition. This intersection operates at an unacceptable LOS E under the PM peak hour conditions without the addition of project related trips and the addition of Project trips would increase the V/C or vehicle delay thresholds beyond acceptable limits. Additionally, Project related trips worsen acceptable LOS D to unacceptable LOS E conditions during the AM peak hour.

*Mitigation Measure:* Construct a second westbound left-turn.

With implementation of this mitigation measure, operations at this intersection would improve to an acceptable LOS D during the AM peak hour. The PM peak hour would continue to operate at LOS E; however, delay and V/C would no longer trigger the threshold of significance. Installation of the second westbound left-turn lane would require restriping of the center median and would not require additional right-of-way. Construction of the mitigation measure shall be the responsibility of the City. With the installation of this mitigation measure, the traffic impact at the Aborn Road & White Road / San Felipe Road intersection would be reduced to a **less-than-significant impact**.

### ***East Capitol Expressway & Aborn Road***

The East Capitol Expressway / Aborn Road intersection operates at an unacceptable LOS F under Cumulative No Project and Cumulative Plus Project Conditions during the AM and PM peak hour. The

increase in critical V/C and delay does not exceed the one percent and four second threshold, respectively. Therefore, the impact to this intersection would be considered **less-than-significant**.

***East Capitol Expressway & Silver Creek Road***

The East Capitol Expressway / Silver Creek Road intersection operates at an unacceptable LOS E under Cumulative No Project and Cumulative Plus Project Conditions during the AM peak hour. The increase in critical V/C and delay does not exceed the one percent and four second threshold, respectively. Therefore, the impact to this intersection would be considered **less-than-significant**.

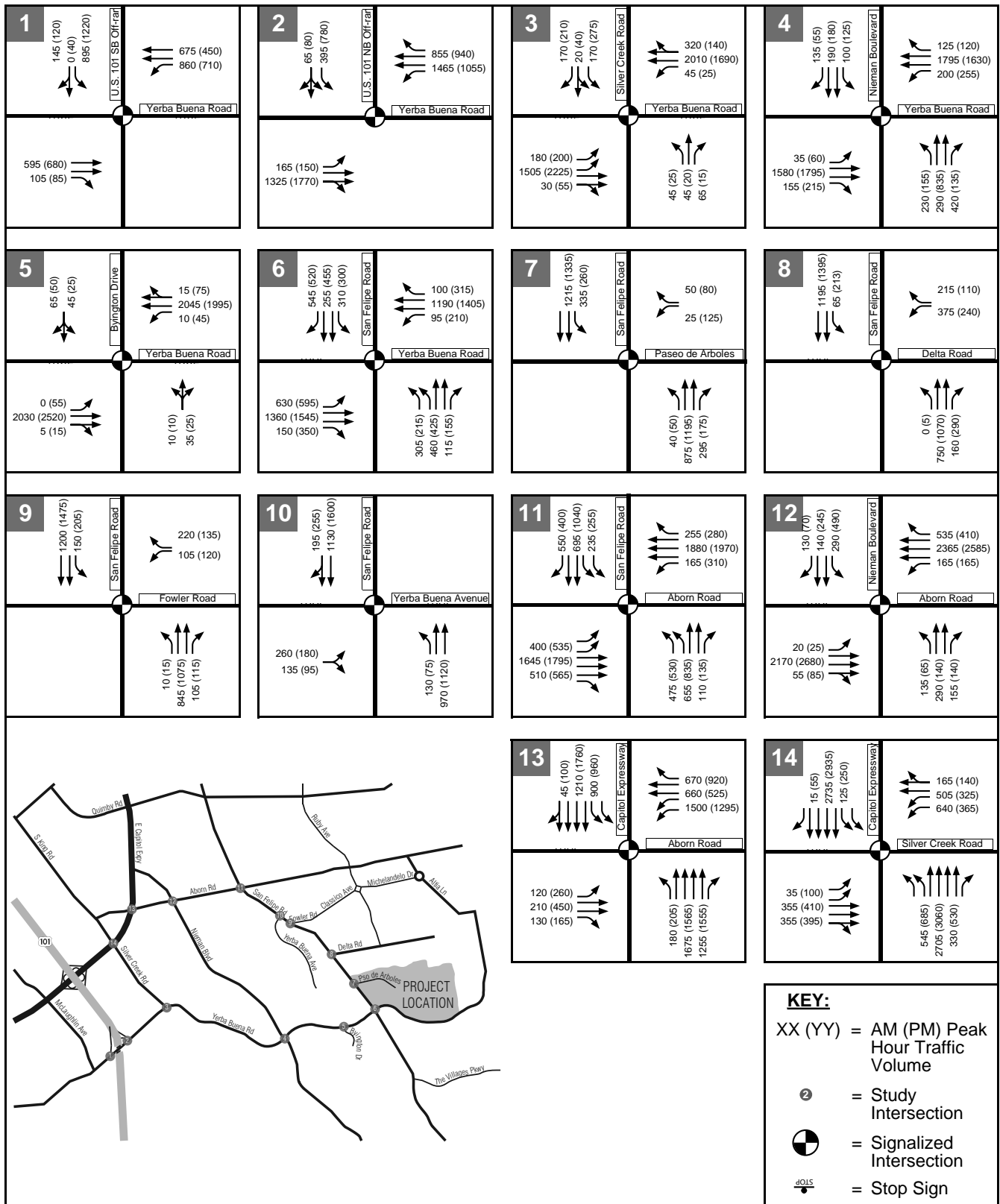

Evergreen Community College

**CUMULATIVE WITHOUT PROJECT LANE GEOMETRIES, TRAFFIC CONTROLS, AND PEAK-HOUR INTERSECTION VOLUMES**

**FIGURE 9**

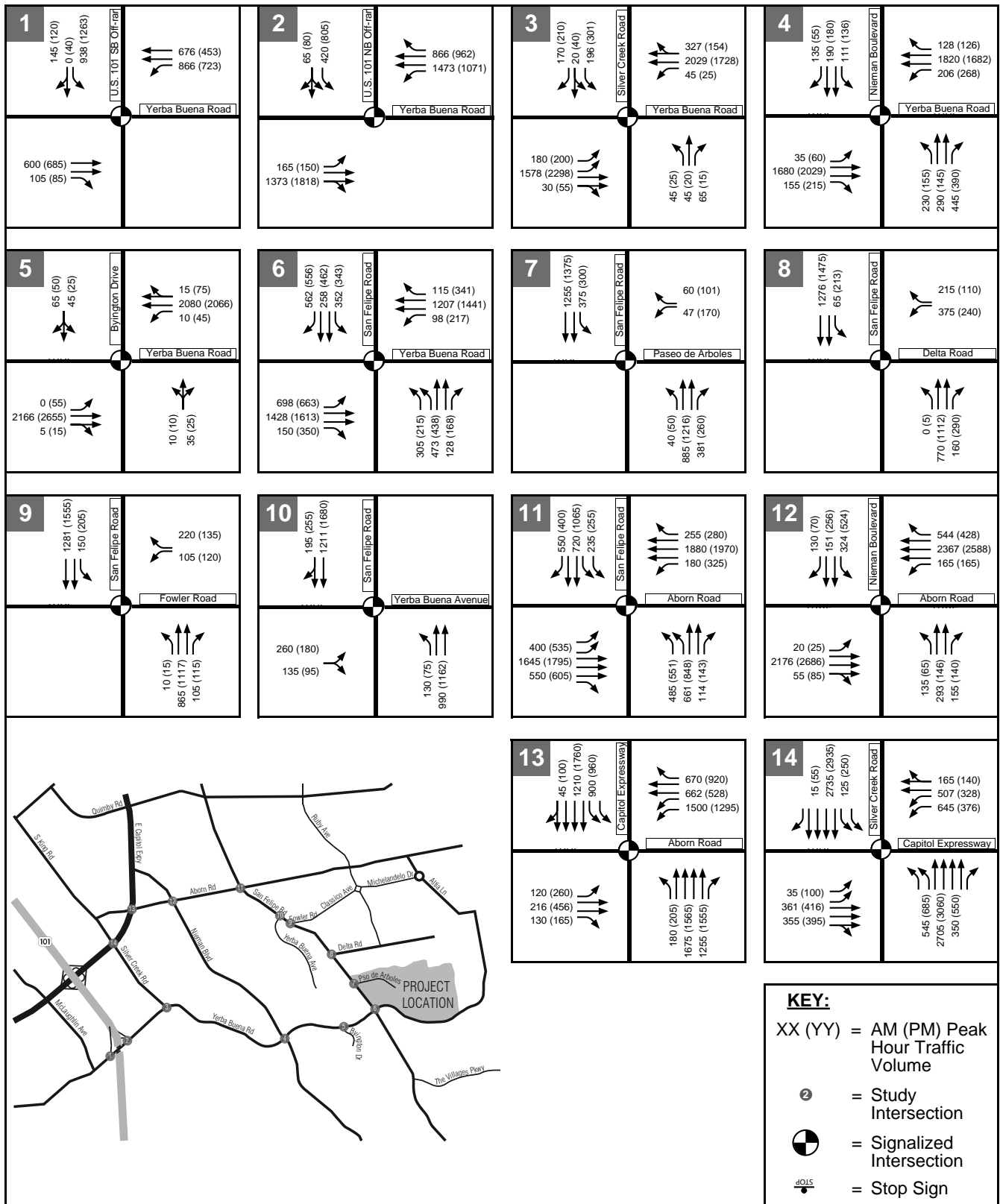

Evergreen Community College

**CUMULATIVE PLUS PROJECT LANE GEOMETRIES, TRAFFIC CONTROLS, AND PEAK-HOUR INTERSECTION VOLUMES**

**FIGURE 10**

**APPENDIX A:  
EXISTING TRAFFIC COUNTS**

LOCATION: US 101 SB Off-Ramp -- Yerba Buena Rd  
 CITY/STATE: San Jose, CA

QC JOB #: 10653002  
 DATE: Wed, Sep 14 2011

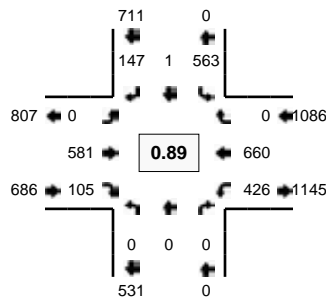

Peak-Hour: 7:25 AM -- 8:25 AM  
 Peak 15-Min: 7:40 AM -- 7:55 AM

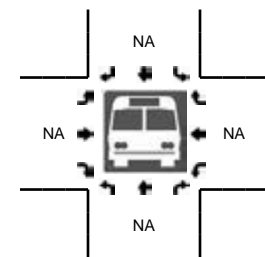
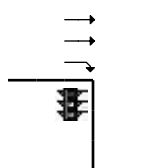
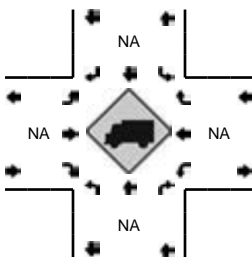
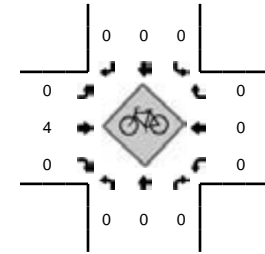
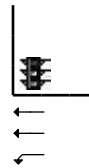
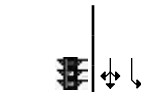
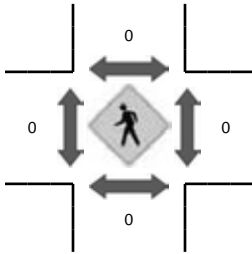
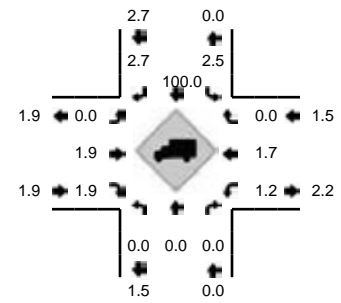

5-Min Count Period Beginning At	US 101 SB Off-Ramp (Northbound)				US 101 SB Off-Ramp (Southbound)				Yerba Buena Rd (Eastbound)				Yerba Buena Rd (Westbound)				Total	Hourly Totals
	Left	Thru	Right	U	Left	Thru	Right	U	Left	Thru	Right	U	Left	Thru	Right	U		
7:00 AM	0	0	0	0	19	0	4	0	0	31	4	0	22	40	0	0	120	
7:05 AM	0	0	0	0	30	0	5	0	0	40	7	0	16	31	0	0	129	
7:10 AM	0	0	0	0	29	0	11	0	0	35	11	0	37	55	0	0	178	
7:15 AM	0	0	0	0	29	0	6	0	0	39	1	0	22	52	0	0	149	
7:20 AM	0	0	0	0	35	0	11	0	0	50	5	0	15	45	0	0	161	
7:25 AM	0	0	0	0	53	0	11	0	0	44	10	0	24	52	0	0	194	
7:30 AM	0	0	0	0	40	1	8	0	0	55	5	0	35	62	0	1	207	
7:35 AM	0	0	0	0	61	0	14	0	0	39	7	0	39	49	0	0	209	
7:40 AM	0	0	0	0	59	0	18	0	0	60	9	0	28	55	0	0	229	
7:45 AM	0	0	0	0	64	0	17	0	0	60	9	0	40	54	0	0	244	
7:50 AM	0	0	0	0	51	0	22	0	0	50	11	0	35	54	0	0	223	
7:55 AM	0	0	0	0	41	0	20	0	0	40	8	0	27	60	0	0	196	2239
8:00 AM	0	0	0	0	54	0	10	0	0	48	14	0	30	52	0	0	208	2327
8:05 AM	0	0	0	0	39	0	12	0	0	55	7	0	53	62	0	0	228	2426
8:10 AM	0	0	0	0	26	0	7	0	0	33	8	0	41	59	0	0	174	2422
8:15 AM	0	0	0	0	32	0	3	0	0	48	11	0	37	50	0	0	181	2454
8:20 AM	0	0	0	0	43	0	5	0	0	49	6	0	36	51	0	0	190	2483
8:25 AM	0	0	0	0	37	0	2	0	0	36	4	0	42	45	0	1	167	2456
8:30 AM	0	0	0	0	33	0	8	0	0	29	4	0	37	41	0	0	152	2401
8:35 AM	0	0	0	0	33	0	5	0	0	45	8	0	36	28	0	0	155	2347
8:40 AM	0	0	0	0	53	0	5	0	0	33	6	0	39	35	0	0	171	2289
8:45 AM	0	0	0	0	46	0	4	0	0	49	10	0	39	36	0	0	184	2229
8:50 AM	0	0	0	0	71	0	6	0	0	37	6	0	23	38	0	1	182	2188
8:55 AM	0	0	0	0	56	0	3	0	0	43	4	0	30	34	0	0	170	2162
Peak 15-Min Flowrates	Northbound				Southbound				Eastbound				Westbound				Total	
All Vehicles	0	0	0	0	696	0	228	0	0	680	116	0	412	652	0	0	2784	
Heavy Trucks	0	0	0	0	12	0	8	0	0	24	0	0	8	8	0	0	60	
Pedestrians	0	0	0	0	0	0	0	0	0	0	0	0	0	0	0	0	0	
Bicycles	0	0	0	0	0	0	0	0	0	0	0	0	0	0	0	0	0	
Railroad																		
Stopped Buses																		

Comments: Please conduct vehicular turning movement counts, pedestrian counts, and bicycle counts at this intersection.

LOCATION: US 101 SB Off-Ramp -- Yerba Buena Rd  
 CITY/STATE: San Jose, CA

QC JOB #: 10653004  
 DATE: Wed, Sep 14 2011

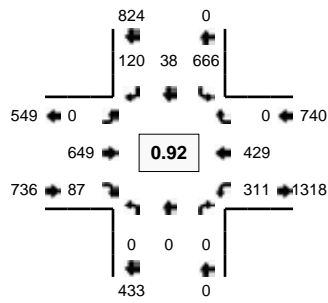

Peak-Hour: 5:00 PM -- 6:00 PM  
 Peak 15-Min: 5:40 PM -- 5:55 PM

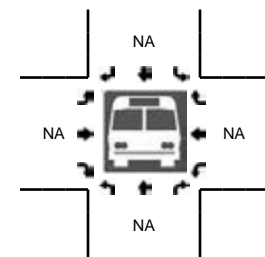
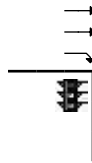
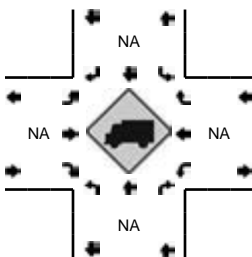
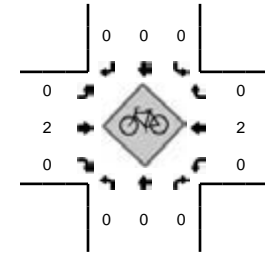
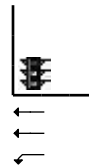
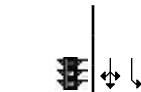
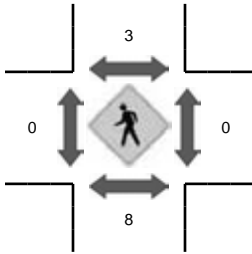
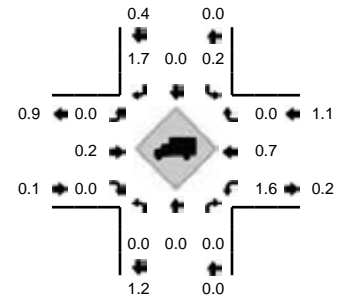

5-Min Count Period Beginning At	US 101 SB Off-Ramp (Northbound)				US 101 SB Off-Ramp (Southbound)				Yerba Buena Rd (Eastbound)				Yerba Buena Rd (Westbound)				Total	Hourly Totals
	Left	Thru	Right	U	Left	Thru	Right	U	Left	Thru	Right	U	Left	Thru	Right	U		
4:00 PM	0	0	0	0	42	2	14	0	0	38	5	0	13	28	0	0	142	
4:05 PM	0	0	0	0	46	0	13	0	0	37	2	0	20	23	0	0	141	
4:10 PM	0	0	0	0	47	1	12	0	0	37	4	0	19	32	0	0	152	
4:15 PM	0	0	0	0	36	1	15	0	0	30	1	0	24	34	0	0	141	
4:20 PM	0	0	0	0	57	6	18	0	0	23	5	0	22	28	0	0	159	
4:25 PM	0	0	0	0	46	2	19	0	0	32	4	0	11	21	0	0	135	
4:30 PM	0	0	0	0	42	0	18	0	0	29	5	0	23	18	0	0	135	
4:35 PM	0	0	0	0	51	0	15	0	0	49	6	0	30	33	0	1	185	
4:40 PM	0	0	0	0	59	1	10	0	0	36	2	0	16	28	0	0	152	
4:45 PM	0	0	0	0	50	4	12	0	0	28	4	0	25	33	0	0	156	
4:50 PM	0	0	0	0	47	1	15	0	0	34	13	0	21	24	0	0	155	
4:55 PM	0	0	0	0	54	0	18	0	0	41	7	0	19	26	0	0	165	1818
5:00 PM	0	0	0	0	43	5	8	0	0	38	7	0	22	34	0	0	157	1833
5:05 PM	0	0	0	0	62	2	9	0	0	53	5	0	19	37	0	0	187	1879
5:10 PM	0	0	0	0	51	1	8	0	0	50	7	0	34	34	0	0	185	1912
5:15 PM	0	0	0	0	52	5	15	0	0	40	6	0	23	29	0	0	170	1941
5:20 PM	0	0	0	0	64	9	15	0	0	47	9	0	30	36	0	1	211	1993
5:25 PM	0	0	0	0	51	2	9	0	0	51	10	0	24	43	0	1	191	2049
5:30 PM	0	0	0	0	56	3	14	0	0	54	10	0	22	30	0	0	189	2103
5:35 PM	0	0	0	0	59	1	8	0	0	68	8	0	24	30	0	0	198	2116
5:40 PM	0	0	0	0	62	1	7	0	0	56	5	0	26	45	0	1	203	2167
5:45 PM	0	0	0	0	56	4	8	0	0	73	7	0	27	33	0	0	208	2219
5:50 PM	0	0	0	0	59	3	6	0	0	62	10	0	31	43	0	0	214	2278
5:55 PM	0	0	0	0	51	2	13	0	0	57	3	0	26	35	0	0	187	2300
Peak 15-Min Flowrates	Northbound				Southbound				Eastbound				Westbound				Total	
	Left	Thru	Right	U	Left	Thru	Right	U	Left	Thru	Right	U	Left	Thru	Right	U		
All Vehicles	0	0	0	0	708	32	84	0	0	764	88	0	336	484	0	4	2500	
Heavy Trucks	0	0	0	0	4	0	0	0	0	0	0	0	4	0	0	0	8	
Pedestrians		8				0				0				0			8	
Bicycles	0	0	0		0	0	0		0	1	0		0	0	0		1	
Railroad																		
Stopped Buses																		

Comments: Please conduct vehicular turning movement counts, pedestrian counts, and bicycle counts at this intersection.

LOCATION: US 101 NB Off-Ramp -- Yerba Buena Rd  
 CITY/STATE: San Jose, CA

QC JOB #: 10653006  
 DATE: Wed, Sep 14 2011

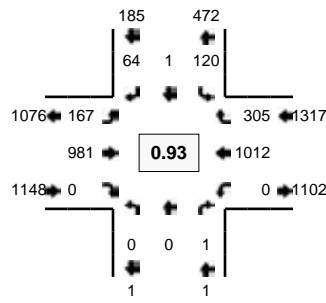

Peak-Hour: 7:25 AM -- 8:25 AM  
 Peak 15-Min: 7:40 AM -- 7:55 AM

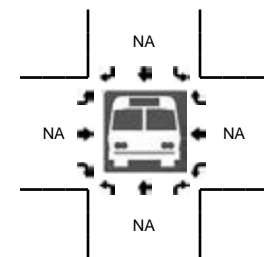
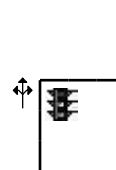
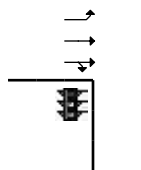
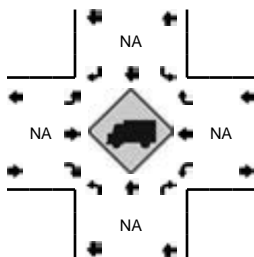
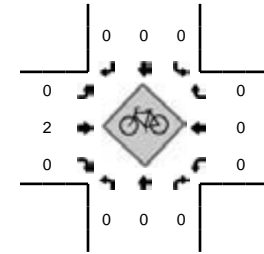
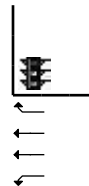
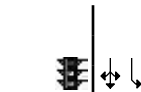
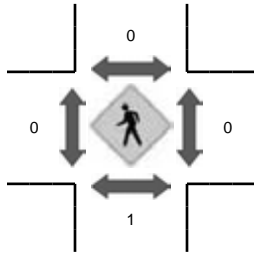
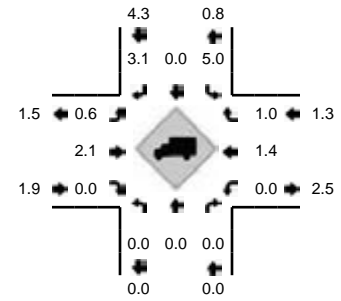

5-Min Count Period Beginning At	US 101 NB Off-Ramp (Northbound)				US 101 NB Off-Ramp (Southbound)				Yerba Buena Rd (Eastbound)				Yerba Buena Rd (Westbound)				Total	Hourly Totals
	Left	Thru	Right	U	Left	Thru	Right	U	Left	Thru	Right	U	Left	Thru	Right	U		
7:00 AM	0	0	0	0	7	0	5	0	8	49	0	0	0	59	35	0	163	
7:05 AM	0	0	0	0	19	0	3	0	9	62	0	0	0	58	25	0	176	
7:10 AM	0	0	0	0	15	0	2	0	8	45	0	0	0	82	32	0	184	
7:15 AM	0	0	0	0	12	0	8	0	18	62	0	0	0	65	31	0	196	
7:20 AM	0	0	0	0	14	0	6	0	10	81	0	0	0	59	21	0	191	
7:25 AM	0	0	0	0	15	0	7	0	7	86	0	0	0	78	22	0	215	
7:30 AM	0	0	0	0	10	0	6	0	20	97	0	0	0	77	15	0	225	
7:35 AM	0	0	0	0	10	0	5	0	15	78	0	0	0	77	20	0	205	
7:40 AM	0	0	0	0	12	0	6	0	12	105	0	0	0	93	14	0	242	
7:45 AM	0	0	1	0	11	0	8	0	13	105	0	0	0	88	30	0	256	
7:50 AM	0	0	0	0	14	0	8	0	17	79	0	0	0	69	30	0	217	
7:55 AM	0	0	0	0	7	0	5	0	13	71	0	0	0	74	25	0	195	2465
8:00 AM	0	0	0	0	9	0	8	0	19	90	0	0	0	90	32	0	248	2550
8:05 AM	0	0	0	0	11	0	3	0	15	62	0	0	0	101	27	0	219	2593
8:10 AM	0	0	0	0	11	0	1	0	12	59	0	0	0	94	37	0	214	2623
8:15 AM	0	0	0	0	5	1	3	0	14	72	0	0	0	82	32	0	209	2636
8:20 AM	0	0	0	0	5	0	4	0	10	77	0	0	0	89	21	0	206	2651
8:25 AM	0	0	1	0	14	0	4	0	5	65	0	0	0	81	34	0	204	2640
8:30 AM	0	0	0	0	5	0	2	0	9	54	0	1	0	69	24	0	164	2579
8:35 AM	0	0	0	0	19	0	2	0	13	61	0	0	0	63	23	0	181	2555
8:40 AM	0	0	0	0	18	0	3	0	5	78	0	0	0	73	12	0	189	2502
8:45 AM	0	0	0	0	11	0	5	0	8	100	0	0	0	64	16	0	204	2450
8:50 AM	0	0	0	0	17	0	3	0	12	90	0	1	0	57	22	0	202	2435
8:55 AM	0	0	0	0	14	0	4	0	3	110	0	0	0	49	29	0	209	2449
Peak 15-Min Flowrates	Northbound				Southbound				Eastbound				Westbound				Total	
	Left	Thru	Right	U	Left	Thru	Right	U	Left	Thru	Right	U	Left	Thru	Right	U		
All Vehicles	0	0	4	0	148	0	88	0	168	1156	0	0	0	1000	296	0	2860	
Heavy Trucks	0	0	0	0	4	0	4	0	4	28	0	0	0	16	0	0	56	
Pedestrians	0	0	0	0	0	0	0	0	0	0	0	0	0	0	0	0	0	
Bicycles	0	0	0	0	0	0	0	0	0	0	0	0	0	0	0	0	0	
Railroad																		
Stopped Buses																		

Comments: Please conduct vehicular turning movement counts, pedestrian counts, and bicycle counts at this intersection.



LOCATION: US 101 NB Off-Ramp -- Yerba Buena Rd  
 CITY/STATE: San Jose, CA

QC JOB #: 10653008  
 DATE: Wed, Sep 14 2011

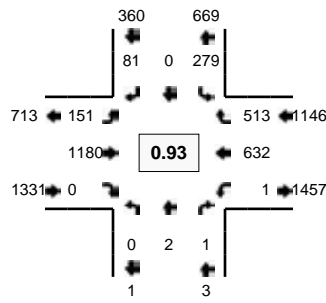

Peak-Hour: 5:00 PM -- 6:00 PM  
 Peak 15-Min: 5:35 PM -- 5:50 PM

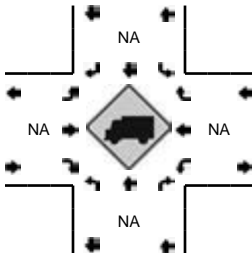
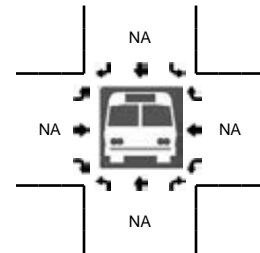
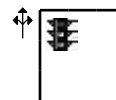
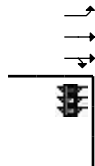
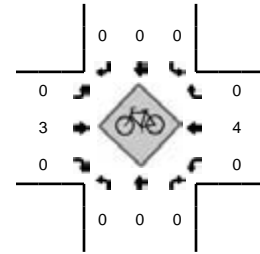
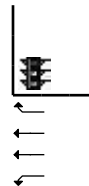
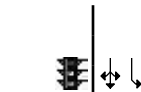
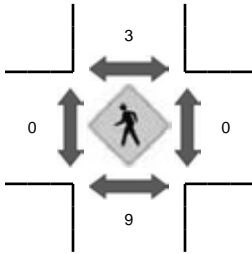
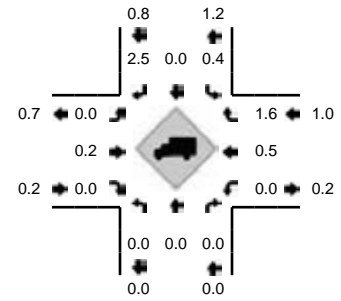

5-Min Count Period Beginning At	US 101 NB Off-Ramp (Northbound)				US 101 NB Off-Ramp (Southbound)				Yerba Buena Rd (Eastbound)				Yerba Buena Rd (Westbound)				Total	Hourly Totals
	Left	Thru	Right	U	Left	Thru	Right	U	Left	Thru	Right	U	Left	Thru	Right	U		
4:00 PM	1	0	0	0	13	0	2	1	8	73	0	0	0	47	46	0	191	
4:05 PM	0	0	0	0	12	0	4	0	11	67	0	0	0	30	27	0	151	
4:10 PM	0	0	0	0	14	0	5	0	11	68	0	0	0	56	40	0	194	
4:15 PM	0	0	0	0	18	0	5	0	9	60	0	0	0	55	56	0	203	
4:20 PM	0	0	0	0	15	0	2	0	10	78	0	0	0	36	38	0	179	
4:25 PM	0	0	0	0	11	0	5	0	7	65	1	0	0	30	31	0	150	
4:30 PM	0	0	0	0	12	0	3	0	10	70	0	0	0	37	40	1	173	
4:35 PM	0	0	0	0	19	0	2	1	13	86	0	0	0	61	37	0	219	
4:40 PM	0	0	0	0	15	0	7	0	11	82	0	0	0	39	49	0	203	
4:45 PM	0	0	0	0	7	0	4	0	9	65	0	0	0	49	30	0	164	
4:50 PM	0	0	0	0	20	0	2	1	10	74	0	0	0	49	35	0	191	
4:55 PM	0	0	0	0	19	0	5	0	12	82	0	0	0	39	37	0	194	2212
5:00 PM	0	1	0	0	14	0	3	0	9	72	0	0	1	50	43	0	193	2214
5:05 PM	0	0	0	0	20	0	5	0	23	92	0	0	0	56	46	0	242	2305
5:10 PM	0	0	0	0	16	0	5	0	16	88	0	0	0	58	52	0	235	2346
5:15 PM	0	0	0	0	22	0	7	0	10	75	0	0	0	47	46	0	207	2350
5:20 PM	0	0	0	0	23	0	14	1	11	102	0	0	0	53	49	0	253	2424
5:25 PM	0	1	0	0	31	0	3	0	15	88	0	0	0	53	39	0	230	2504
5:30 PM	0	0	1	0	29	0	6	0	5	116	0	0	0	46	41	0	244	2575
5:35 PM	0	0	0	0	21	0	15	0	15	117	0	0	0	48	32	0	248	2604
5:40 PM	0	0	0	0	20	0	6	0	15	107	0	0	0	57	44	0	249	2650
5:45 PM	0	0	0	0	28	0	5	0	10	116	0	0	0	59	47	0	265	2751
5:50 PM	0	0	0	0	29	0	9	1	14	95	0	0	0	61	35	0	244	2804
5:55 PM	0	0	0	0	23	0	3	1	8	112	0	0	0	44	39	0	230	2840
Peak 15-Min Flowrates	Northbound				Southbound				Eastbound				Westbound				Total	
All Vehicles	0	0	0	0	276	0	104	0	160	1360	0	0	0	656	492	0	3048	
Heavy Trucks	0	0	0	0	0	0	0	0	0	4	0	0	0	4	12	0	20	
Pedestrians	0	0	0	0	0	0	0	0	0	0	0	0	0	0	0	0	0	
Bicycles	0	0	0	0	0	0	0	0	0	1	0	0	0	0	0	0	1	
Railroad																		
Stopped Buses																		

Comments: Please conduct vehicular turning movement counts, pedestrian counts, and bicycle counts at this intersection.

**LOCATION:** Silver Creek Rd -- Yerba Buena Rd  
**CITY/STATE:** San Jose, CA

**QC JOB #:** 10653010  
**DATE:** Wed, Sep 14 2011

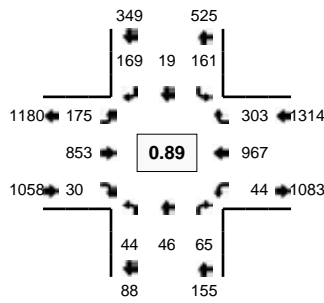

**Peak-Hour: 7:25 AM -- 8:25 AM**  
**Peak 15-Min: 7:40 AM -- 7:55 AM**

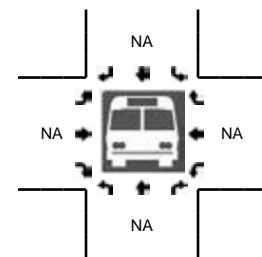
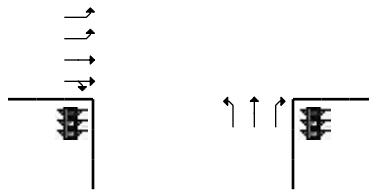
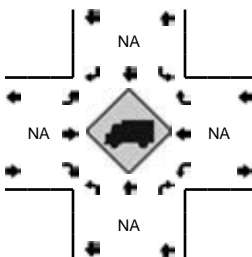
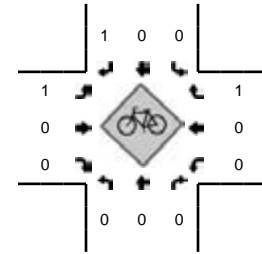
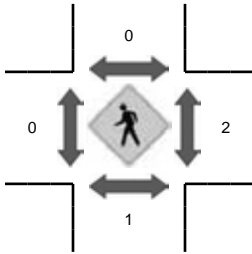
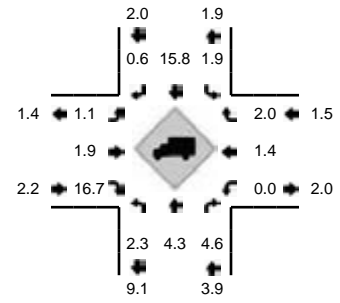

5-Min Count Period Beginning At	Silver Creek Rd (Northbound)				Silver Creek Rd (Southbound)				Yerba Buena Rd (Eastbound)				Yerba Buena Rd (Westbound)				Total	Hourly Totals
	Left	Thru	Right	U	Left	Thru	Right	U	Left	Thru	Right	U	Left	Thru	Right	U		
7:00 AM	5	5	2	0	14	1	16	0	25	15	2	0	3	44	43	0	175	
7:05 AM	6	8	4	0	14	2	16	0	38	31	1	0	0	58	47	1	226	
7:10 AM	3	3	2	0	25	12	25	0	22	57	2	0	0	75	30	0	256	
7:15 AM	3	1	2	0	24	2	19	0	12	59	1	0	1	66	25	0	215	
7:20 AM	4	2	0	0	12	0	3	0	10	61	1	0	1	51	19	0	164	
7:25 AM	1	0	3	0	8	2	11	1	11	82	4	0	1	85	23	0	232	
7:30 AM	2	3	2	0	13	0	12	0	13	84	0	0	0	82	19	1	231	
7:35 AM	3	4	3	0	25	2	9	0	10	72	2	0	0	61	20	1	212	
7:40 AM	4	3	3	0	18	1	10	0	16	86	3	0	2	63	32	0	241	
7:45 AM	1	5	11	0	10	0	20	0	21	103	3	0	1	82	28	0	285	
7:50 AM	5	8	18	0	16	2	13	0	14	78	3	0	3	95	24	0	279	
7:55 AM	3	3	12	0	15	1	11	0	12	73	5	0	6	71	24	2	238	2754
8:00 AM	3	2	8	0	6	4	15	0	20	58	1	0	7	87	25	0	236	2815
8:05 AM	5	3	1	0	14	1	17	0	19	67	3	0	8	96	45	0	279	2868
8:10 AM	5	8	0	0	15	4	24	0	18	41	1	0	9	90	29	0	244	2856
8:15 AM	6	4	1	0	10	2	14	0	11	60	2	0	0	70	19	1	200	2841
8:20 AM	6	3	3	0	10	0	13	0	10	49	3	0	2	85	15	0	199	2876
8:25 AM	4	6	2	0	11	0	20	0	8	50	2	0	0	66	19	0	188	2832
8:30 AM	1	4	1	0	11	1	14	1	13	61	5	0	4	60	15	0	191	2792
8:35 AM	3	1	0	0	12	1	17	1	4	58	0	0	0	51	18	0	166	2746
8:40 AM	1	0	1	0	26	2	18	0	13	79	3	0	1	57	14	0	215	2720
8:45 AM	0	3	4	0	17	2	13	0	6	85	3	0	0	62	17	0	212	2647
8:50 AM	6	4	0	0	19	4	5	0	4	94	3	0	0	57	23	0	219	2587
8:55 AM	4	6	2	0	20	1	10	0	9	95	2	0	1	57	17	0	224	2573
Peak 15-Min Flowrates	Northbound				Southbound				Eastbound				Westbound				Total	
All Vehicles	40	64	128	0	176	12	172	0	204	1068	36	0	24	960	336	0	3220	
Heavy Trucks	0	4	8		0	4	4		8	16	4		0	8	8		64	
Pedestrians	0	0	0		0	0	0		0	0	0		0	0	0		0	
Bicycles	0	0	0		0	0	0		1	0	0		0	0	0		1	
Railroad																		
Stopped Buses																		

Comments: Please conduct vehicular turning movement counts, pedestrian counts, and bicycle counts at this intersection.

**LOCATION:** Silver Creek Rd -- Yerba Buena Rd  
**CITY/STATE:** San Jose, CA

**QC JOB #:** 10653012  
**DATE:** Wed, Sep 14 2011

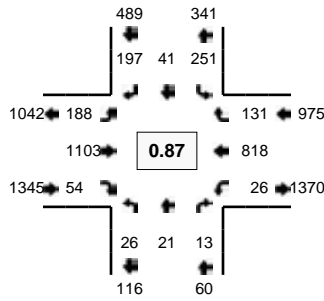

**Peak-Hour: 5:00 PM -- 6:00 PM**  
**Peak 15-Min: 5:40 PM -- 5:55 PM**

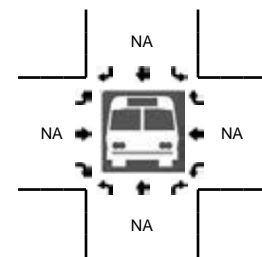
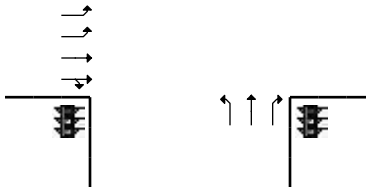
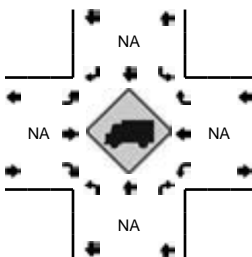
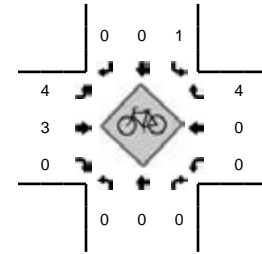
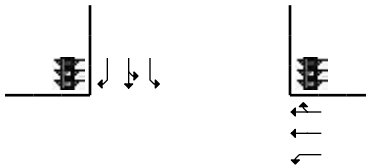
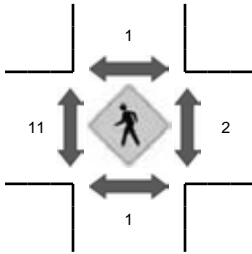
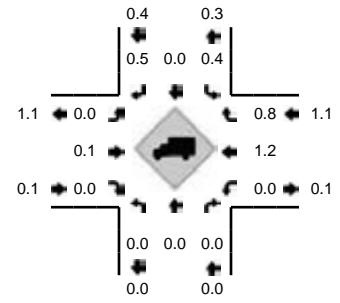

5-Min Count Period Beginning At	Silver Creek Rd (Northbound)				Silver Creek Rd (Southbound)				Yerba Buena Rd (Eastbound)				Yerba Buena Rd (Westbound)				Total	Hourly Totals
	Left	Thru	Right	U	Left	Thru	Right	U	Left	Thru	Right	U	Left	Thru	Right	U		
4:00 PM	1	1	0	0	8	3	17	0	15	59	6	0	3	62	11	0	186	
4:05 PM	0	3	1	0	12	0	12	0	15	59	3	0	1	49	14	0	169	
4:10 PM	1	4	4	0	8	3	15	0	16	60	2	0	1	78	3	0	195	
4:15 PM	2	2	0	0	9	1	12	0	15	56	2	0	0	69	7	0	175	
4:20 PM	0	0	0	0	13	2	15	0	10	42	4	0	1	71	13	0	171	
4:25 PM	1	0	1	0	13	4	10	0	18	73	3	0	1	32	6	0	162	
4:30 PM	1	1	1	0	9	8	16	0	16	54	4	0	2	65	10	0	187	
4:35 PM	3	3	0	0	10	1	21	0	12	64	2	0	0	66	11	0	193	
4:40 PM	3	0	0	0	10	2	10	1	11	93	4	0	0	66	14	0	214	
4:45 PM	0	1	0	0	8	6	11	0	4	49	0	0	0	64	10	1	154	
4:50 PM	1	0	0	0	12	1	13	0	13	78	3	0	0	57	13	0	191	
4:55 PM	0	2	3	0	9	3	15	1	9	66	1	0	1	55	13	0	178	2175
5:00 PM	1	1	2	0	16	1	16	0	11	81	3	0	1	70	12	0	215	2204
5:05 PM	8	4	0	0	15	3	15	1	14	74	1	0	3	62	12	0	212	2247
5:10 PM	0	0	1	0	21	4	25	0	15	80	0	1	4	76	13	0	240	2292
5:15 PM	0	0	1	0	17	2	6	0	15	82	6	0	4	80	11	1	225	2342
5:20 PM	4	2	0	0	19	0	22	0	17	84	5	0	2	69	8	0	232	2403
5:25 PM	4	1	1	0	17	4	12	0	14	76	8	0	2	72	11	1	223	2464
5:30 PM	4	5	4	0	27	6	16	0	19	85	4	0	1	47	9	0	227	2504
5:35 PM	2	2	2	0	15	5	15	0	17	114	5	0	1	67	6	2	253	2564
5:40 PM	0	4	0	0	19	2	17	0	15	123	4	0	0	78	6	1	269	2619
5:45 PM	2	1	0	0	40	4	17	0	15	105	6	0	0	67	13	0	270	2735
5:50 PM	0	1	2	0	21	7	18	1	15	122	6	0	1	75	18	0	287	2831
5:55 PM	1	0	0	0	22	3	18	0	20	77	6	0	2	55	12	0	216	2869
Peak 15-Min Flowrates	Northbound				Southbound				Eastbound				Westbound				Total	
	Left	Thru	Right	U	Left	Thru	Right	U	Left	Thru	Right	U	Left	Thru	Right	U		
All Vehicles	8	24	8	0	320	52	208	4	180	1400	64	0	4	880	148	4	3304	
Heavy Trucks	0	0	0		0	0	4		0	0	0		0	4	4		12	
Pedestrians	0	0	0		0	0	0		0	4	0		0	8	0		12	
Bicycles	0	0	0		0	0	0		0	1	0		0	0	0		1	
Railroad																		
Stopped Buses																		

Comments: Please conduct vehicular turning movement counts, pedestrian counts, and bicycle counts at this intersection.

**LOCATION:** Nieman Blvd -- Yerba Buena Rd  
**CITY/STATE:** San Jose, CA

**QC JOB #:** 10653014  
**DATE:** Wed, Sep 14 2011

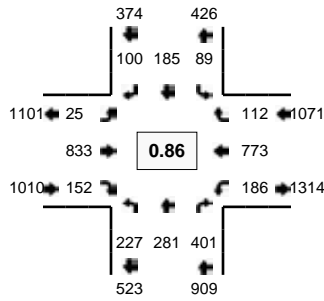

**Peak-Hour: 7:10 AM -- 8:10 AM**  
**Peak 15-Min: 7:50 AM -- 8:05 AM**

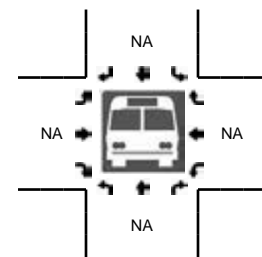
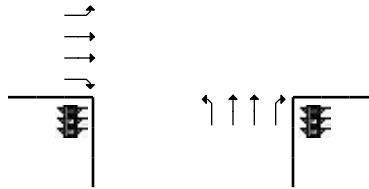
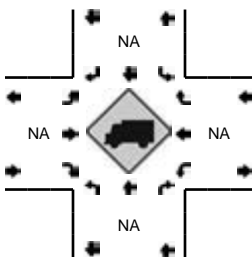
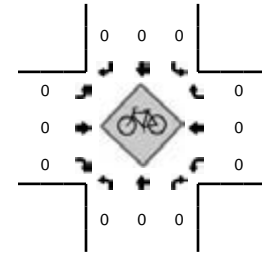
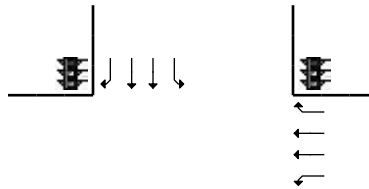
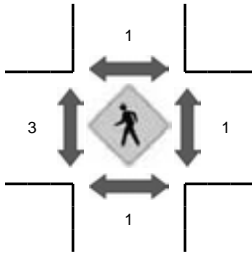
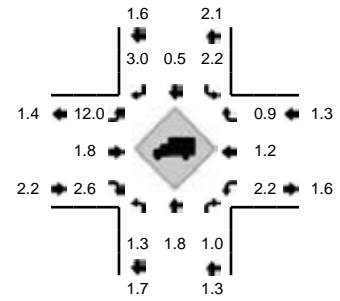

5-Min Count Period Beginning At	Nieman Blvd (Northbound)				Nieman Blvd (Southbound)				Yerba Buena Rd (Eastbound)				Yerba Buena Rd (Westbound)				Total	Hourly Totals	
	Left	Thru	Right	U	Left	Thru	Right	U	Left	Thru	Right	U	Left	Thru	Right	U			
7:00 AM	18	4	8	0	2	4	3	0	0	20	8	0	2	48	4	0	121		
7:05 AM	32	11	11	0	9	5	5	0	4	18	12	0	7	50	7	0	171		
7:10 AM	21	6	21	0	3	3	4	0	3	55	15	0	16	62	1	0	210		
7:15 AM	18	13	27	0	7	10	4	0	1	64	10	0	13	45	3	0	215		
7:20 AM	18	9	61	0	13	5	4	0	1	59	9	0	10	55	7	0	251		
7:25 AM	27	17	31	0	5	4	1	0	1	88	8	0	11	55	9	0	257		
7:30 AM	10	19	54	0	6	6	5	0	1	89	9	0	8	77	11	0	295		
7:35 AM	13	12	29	0	4	9	3	0	0	77	12	0	17	64	20	0	260		
7:40 AM	22	24	38	0	2	5	3	0	2	90	12	0	21	68	12	0	299		
7:45 AM	8	33	26	0	4	10	7	1	1	73	14	0	22	90	15	0	304		
7:50 AM	20	57	43	0	10	27	14	0	4	64	18	1	12	57	19	0	346		
7:55 AM	20	47	22	0	2	30	21	4	3	60	14	0	21	56	6	0	306	3035	
8:00 AM	30	33	33	0	15	49	18	4	5	42	14	0	14	65	8	0	330	3244	
8:05 AM	20	11	16	0	9	27	16	0	2	72	17	0	21	79	1	0	291	3364	
8:10 AM	21	15	22	0	9	10	3	0	1	42	11	0	17	57	2	0	210	3364	
8:15 AM	21	20	24	0	2	11	3	0	3	45	12	0	9	57	4	0	211	3360	
8:20 AM	8	7	17	0	2	5	4	0	1	59	8	0	14	58	4	0	187	3296	
8:25 AM	17	11	21	1	3	7	0	0	0	41	16	0	22	48	4	0	191	3230	
8:30 AM	11	5	24	0	1	3	0	0	0	49	14	0	18	50	2	0	177	3112	
8:35 AM	8	11	30	0	2	5	4	0	0	48	10	0	21	61	4	0	204	3056	
8:40 AM	13	9	35	1	3	10	3	0	1	84	15	1	11	39	2	0	227	2984	
8:45 AM	13	17	26	1	10	8	7	0	1	89	9	0	17	58	2	0	258	2938	
8:50 AM	11	12	37	1	1	6	3	0	0	121	9	1	25	57	8	0	292	2884	
8:55 AM	11	9	49	0	9	7	1	0	2	105	6	0	15	46	2	0	262	2840	
Peak 15-Min Flowrates	Northbound				Southbound				Eastbound				Westbound				Total		
All Vehicles	280	548	392	0	108	424	212	32	48	664	184	4	188	712	132	0	3928		
Heavy Trucks	4	0	4		0	0	4		0	4	0		0	16	4		36		
Pedestrians		4				0				8				0			12		
Bicycles	0	0	0		0	0	0		0	0	0		0	0	0		0		
Railroad																			
Stopped Buses																			

Comments: Please conduct vehicular turning movement counts, pedestrian counts, and bicycle counts at this intersection.

# Traffic Data Service

Campbell, CA  
 (408) 377-2988  
 tdsbay@cs.com

File Name : 2PM FINAL  
 Site Code : 00000002  
 Start Date : 10/25/2011  
 Page No : 1

## Groups Printed- Vehicles

Start Time	NIEMAN BLVD Southbound					YERBA BUENA RD Westbound					SILVER CREEK VALLEY RD Northbound					YERBA BUENA RD Eastbound					Int. Total
	Left	Thru	Right	Peds	App. Total	Left	Thru	Right	Peds	App. Total	Left	Thru	Right	Peds	App. Total	Left	Thru	Right	Peds	App. Total	
04:00 PM	10	35	6	0	51	50	142	16	1	209	42	35	47	0	124	0	117	44	0	161	545
04:15 PM	18	33	6	0	57	62	129	15	0	206	40	32	36	0	108	3	143	56	0	202	573
04:30 PM	17	33	7	0	57	43	155	14	0	212	39	20	49	0	108	5	145	67	0	217	594
04:45 PM	20	28	6	0	54	55	167	14	0	236	44	27	49	0	120	4	138	60	0	202	612
Total	65	129	25	0	219	210	593	59	1	863	165	114	181	0	460	12	543	227	0	782	2324
05:00 PM	27	30	7	0	64	53	150	15	0	218	43	31	51	0	125	4	180	48	0	232	639
05:15 PM	21	37	5	0	63	53	177	23	0	253	44	38	69	0	151	7	172	55	0	234	701
05:30 PM	31	64	12	0	107	61	174	25	1	261	41	38	84	0	163	7	240	57	0	304	835
05:45 PM	25	39	6	2	72	42	174	20	0	236	28	30	111	0	169	3	249	54	0	306	783
Total	104	170	30	2	306	209	675	83	1	968	156	137	315	0	608	21	841	214	0	1076	2958
Grand Total	169	299	55	2	525	419	1268	142	2	1831	321	251	496	0	1068	33	1384	441	0	1858	5282
Apprch %	32.2	57	10.5	0.4		22.9	69.3	7.8	0.1		30.1	23.5	46.4	0		1.8	74.5	23.7	0		
Total %	3.2	5.7	1	0	9.9	7.9	24	2.7	0	34.7	6.1	4.8	9.4	0	20.2	0.6	26.2	8.3	0	35.2	

Start Time	NIEMAN BLVD Southbound					YERBA BUENA RD Westbound					SILVER CREEK VALLEY RD Northbound					YERBA BUENA RD Eastbound					Int. Total
	Left	Thru	Right	Peds	App. Total	Left	Thru	Right	Peds	App. Total	Left	Thru	Right	Peds	App. Total	Left	Thru	Right	Peds	App. Total	
Peak Hour Analysis From 04:00 PM to 05:45 PM - Peak 1 of 1																					
Peak Hour for Entire Intersection Begins at 05:00 PM																					
05:00 PM	27	30	7	0	64	53	150	15	0	218	43	31	51	0	125	4	180	48	0	232	639
05:15 PM	21	37	5	0	63	53	177	23	0	253	44	38	69	0	151	7	172	55	0	234	701
05:30 PM	31	64	12	0	107	61	174	25	1	261	41	38	84	0	163	7	240	57	0	304	835
05:45 PM	25	39	6	2	72	42	174	20	0	236	28	30	111	0	169	3	249	54	0	306	783
Total Volume	104	170	30	2	306	209	675	83	1	968	156	137	315	0	608	21	841	214	0	1076	2958
% App. Total	34	55.6	9.8	0.7		21.6	69.7	8.6	0.1		25.7	22.5	51.8	0		2	78.2	19.9	0		
PHF	.839	.664	.625	.250	.715	.857	.953	.830	.250	.927	.886	.901	.709	.000	.899	.750	.844	.939	.000	.879	.886

# Traffic Data Service

Campbell, CA

(408) 377-2988

tdsbay@cs.com

File Name : 2PM FINAL

Site Code : 00000002

Start Date : 10/25/2011

Page No : 2

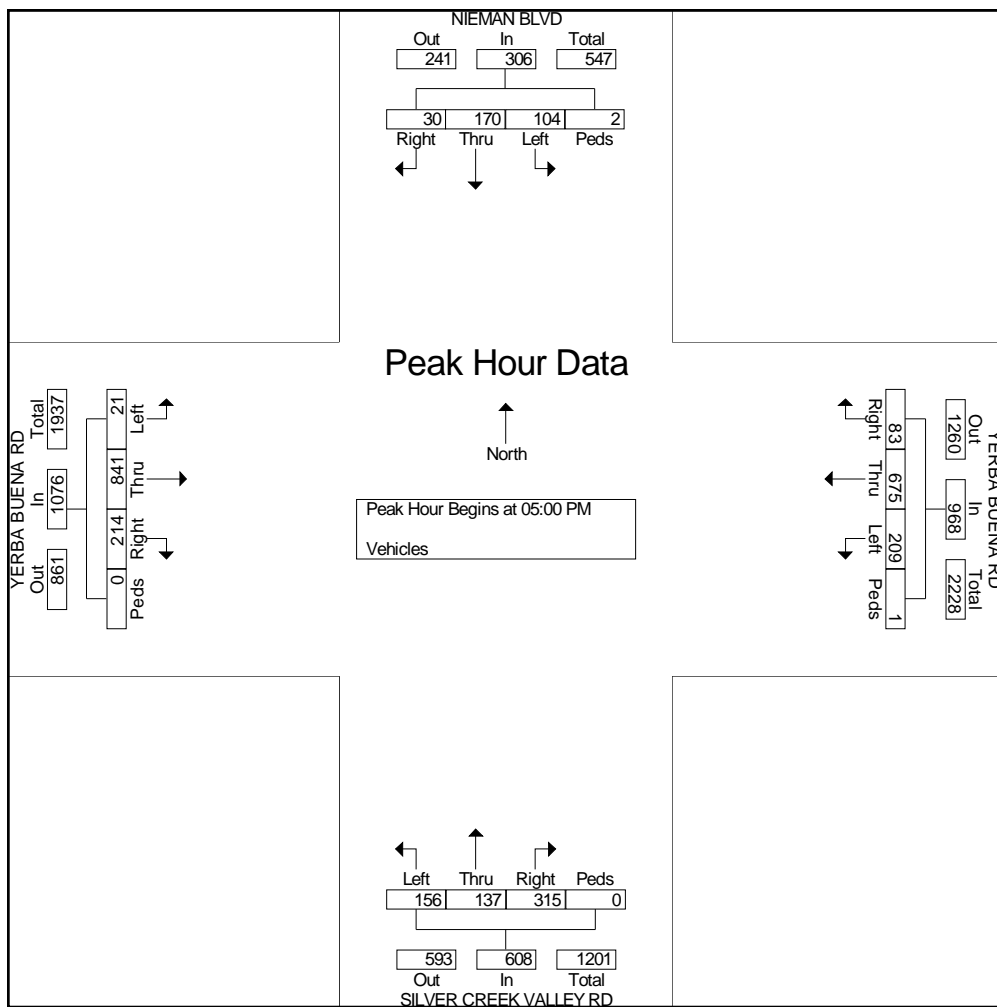

LOCATION: Byington Dr -- Yerba Buena Rd  
 CITY/STATE: San Jose, CA

QC JOB #: 10653018  
 DATE: Wed, Sep 14 2011

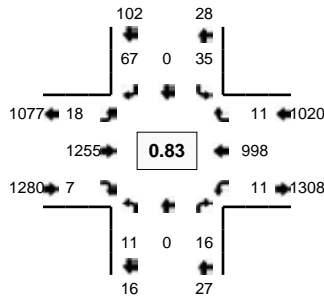

Peak-Hour: 7:20 AM -- 8:20 AM  
 Peak 15-Min: 7:30 AM -- 7:45 AM

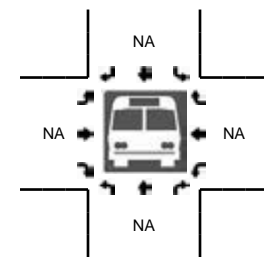
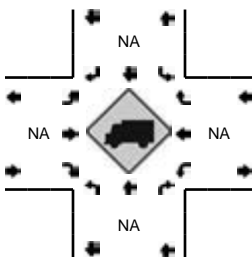
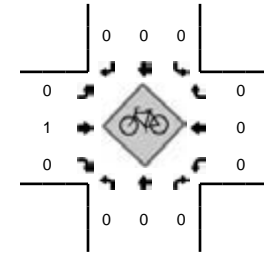
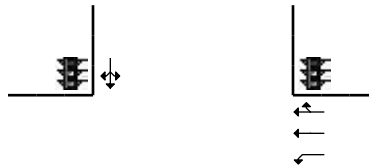
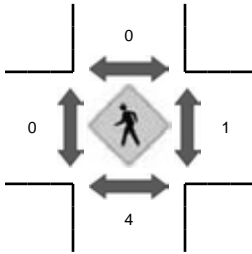
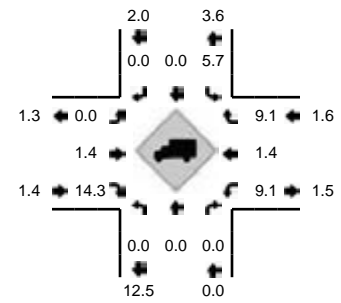

5-Min Count Period Beginning At	Byington Dr (Northbound)				Byington Dr (Southbound)				Yerba Buena Rd (Eastbound)				Yerba Buena Rd (Westbound)				Total	Hourly Totals
	Left	Thru	Right	U	Left	Thru	Right	U	Left	Thru	Right	U	Left	Thru	Right	U		
7:00 AM	0	0	2	0	4	0	7	0	2	23	0	0	2	45	1	0	86	
7:05 AM	2	0	1	0	0	0	8	0	0	42	0	0	1	60	0	0	114	
7:10 AM	1	0	1	0	3	0	4	0	2	78	1	0	0	76	0	0	166	
7:15 AM	0	0	0	0	2	0	2	0	1	101	0	0	1	61	1	0	169	
7:20 AM	2	0	0	0	2	0	3	0	1	127	0	0	1	70	1	0	207	
7:25 AM	1	0	4	0	2	0	1	0	1	123	0	0	2	76	2	0	212	
7:30 AM	1	0	1	0	6	0	8	0	1	140	1	0	0	77	0	0	235	
7:35 AM	1	0	0	0	3	0	6	0	0	110	0	0	2	101	0	1	224	
7:40 AM	1	0	1	0	0	0	10	0	2	139	0	0	1	118	3	0	275	
7:45 AM	0	0	1	0	3	0	6	0	1	95	0	0	0	100	1	1	208	
7:50 AM	1	0	0	0	2	0	7	0	2	122	1	0	0	79	0	0	214	
7:55 AM	0	0	1	0	4	0	7	0	2	69	2	1	0	81	1	0	168	2278
8:00 AM	0	0	2	0	4	0	4	0	1	97	1	0	0	75	0	0	184	2376
8:05 AM	3	0	4	0	4	0	4	0	1	75	0	0	1	67	0	0	159	2421
8:10 AM	0	0	1	0	2	0	3	0	3	81	1	0	0	80	2	0	173	2428
8:15 AM	1	0	1	0	3	0	8	0	2	77	1	0	2	74	1	0	170	2429
8:20 AM	0	0	1	0	1	0	5	0	1	75	1	0	2	75	3	1	165	2387
8:25 AM	0	0	0	0	3	0	4	0	1	57	0	0	2	69	1	2	139	2314
8:30 AM	0	0	1	0	0	0	5	0	1	83	1	0	1	69	2	0	163	2242
8:35 AM	2	0	1	0	0	0	0	0	1	76	0	0	1	57	1	0	139	2157
8:40 AM	0	0	0	0	1	0	8	0	0	119	0	0	0	66	1	0	195	2077
8:45 AM	1	0	1	0	1	0	5	0	0	118	0	0	1	63	0	1	191	2060
8:50 AM	0	0	1	0	2	0	1	0	0	153	1	0	0	89	4	1	252	2098
8:55 AM	0	0	1	0	3	0	4	0	1	167	0	0	1	74	1	0	252	2182
Peak 15-Min Flowrates	Northbound				Southbound				Eastbound				Westbound				Total	
	Left	Thru	Right	U	Left	Thru	Right	U	Left	Thru	Right	U	Left	Thru	Right	U		
All Vehicles	12	0	8	0	36	0	96	0	12	1556	4	0	12	1184	12	4	2936	
Heavy Trucks	0	0	0		0	0	0		0	24	0		0	12	4		40	
Pedestrians		4				0				0				0			4	
Bicycles	0	0	0		0	0	0		0	0	0		0	0	0		0	
Railroad																		
Stopped Buses																		

Comments: Please conduct vehicular turning movement counts, pedestrian counts, and bicycle counts at this intersection.

LOCATION: Byington Dr -- Yerba Buena Rd  
 CITY/STATE: San Jose, CA

QC JOB #: 10653020  
 DATE: Wed, Sep 14 2011

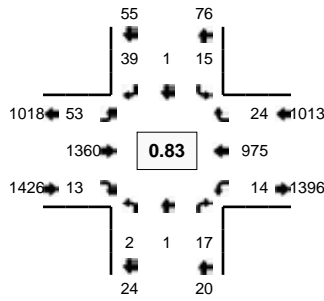

Peak-Hour: 5:00 PM -- 6:00 PM  
 Peak 15-Min: 5:40 PM -- 5:55 PM

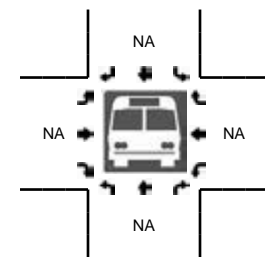
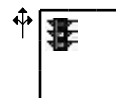
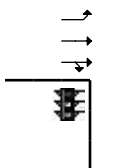
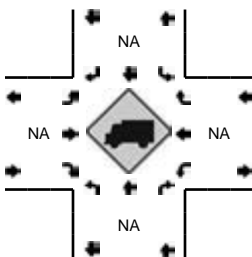
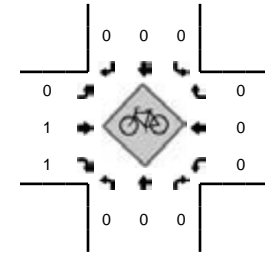
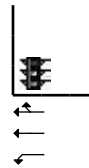
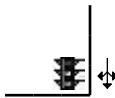
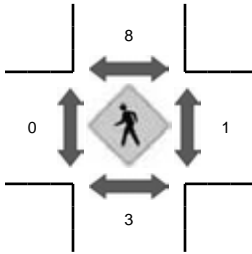
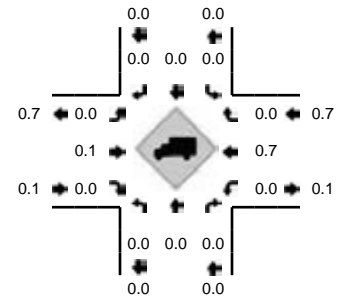

5-Min Count Period Beginning At	Byington Dr (Northbound)				Byington Dr (Southbound)				Yerba Buena Rd (Eastbound)				Yerba Buena Rd (Westbound)				Total	Hourly Totals
	Left	Thru	Right	U	Left	Thru	Right	U	Left	Thru	Right	U	Left	Thru	Right	U		
4:00 PM	0	0	0	0	3	0	3	0	5	59	0	0	0	55	1	2	128	
4:05 PM	0	0	1	0	1	0	2	0	0	59	0	0	0	95	3	0	161	
4:10 PM	0	0	0	0	1	0	1	0	1	54	1	0	0	73	2	0	133	
4:15 PM	1	0	0	0	0	0	1	0	5	67	0	0	0	82	0	0	156	
4:20 PM	0	0	0	0	0	0	1	0	4	64	0	0	1	46	1	0	117	
4:25 PM	1	0	0	0	1	0	3	0	1	78	0	0	0	48	0	0	132	
4:30 PM	0	0	1	0	2	0	3	0	1	53	1	0	0	67	1	0	129	
4:35 PM	0	0	0	0	0	0	0	0	2	71	2	0	0	77	2	0	154	
4:40 PM	1	0	4	0	4	0	0	0	1	72	0	0	0	84	4	0	170	
4:45 PM	0	0	0	0	1	0	1	0	3	67	1	0	0	78	3	0	154	
4:50 PM	0	0	0	0	2	0	3	0	2	70	0	0	0	66	2	0	145	
4:55 PM	0	0	1	0	1	0	2	0	6	85	1	0	2	73	2	0	173	1752
5:00 PM	0	0	2	0	1	0	2	0	3	86	1	0	2	87	2	0	186	1810
5:05 PM	1	0	1	0	0	0	3	0	7	72	3	0	2	83	2	1	175	1824
5:10 PM	0	0	3	0	3	0	2	0	5	97	0	0	1	106	5	1	223	1914
5:15 PM	1	0	1	0	1	0	3	0	6	89	0	1	2	68	2	1	175	1933
5:20 PM	0	0	0	0	1	0	4	0	1	98	0	0	0	85	3	1	193	2009
5:25 PM	0	0	0	0	1	0	5	0	3	97	4	0	0	67	1	0	178	2055
5:30 PM	0	0	4	0	2	0	3	0	5	120	0	1	0	61	1	0	197	2123
5:35 PM	0	0	3	0	1	0	1	0	4	122	1	0	0	70	1	0	203	2172
5:40 PM	0	0	0	0	2	1	6	0	5	123	0	0	1	105	2	0	245	2247
5:45 PM	0	1	0	0	2	0	5	0	8	165	1	0	1	88	0	0	271	2364
5:50 PM	0	0	0	0	0	0	2	0	1	156	1	0	1	79	1	0	241	2460
5:55 PM	0	0	3	0	1	0	3	0	3	135	2	0	0	76	4	0	227	2514
Peak 15-Min Flowrates	Northbound				Southbound				Eastbound				Westbound				Total	
	Left	Thru	Right	U	Left	Thru	Right	U	Left	Thru	Right	U	Left	Thru	Right	U		
All Vehicles	0	4	0	0	16	4	52	0	56	1776	8	0	12	1088	12	0	3028	
Heavy Trucks	0	0	0	0	0	0	0	0	0	0	0	0	0	0	0	0	0	
Pedestrians		4				0				0				0			4	
Bicycles	0	0	0		0	0	0		0	0	0		0	0	0		0	
Railroad																		
Stopped Buses																		

Comments: Please conduct vehicular turning movement counts, pedestrian counts, and bicycle counts at this intersection.



LOCATION: San Felipe Rd -- Yerba Buena Rd  
 CITY/STATE: San Jose, CA

QC JOB #: 10653022  
 DATE: Wed, Sep 14 2011

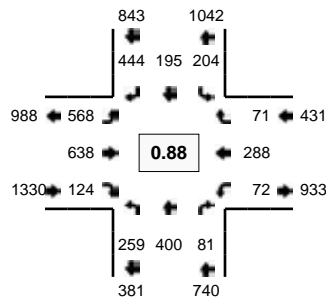

Peak-Hour: 7:20 AM -- 8:20 AM  
 Peak 15-Min: 7:35 AM -- 7:50 AM

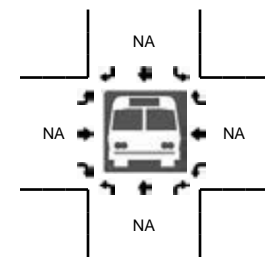
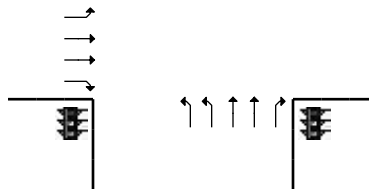
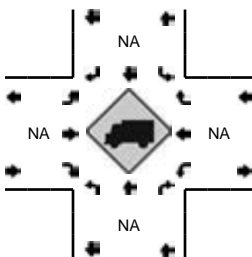
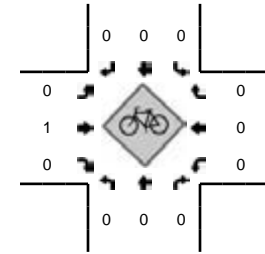
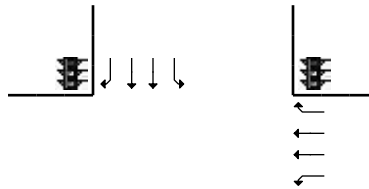
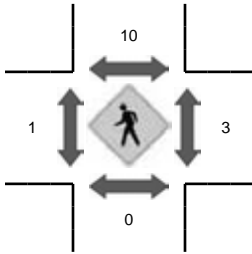
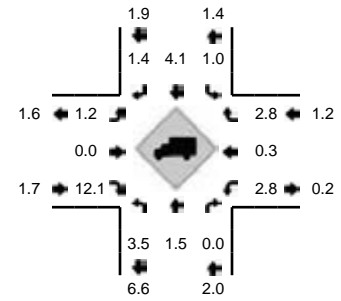

5-Min Count Period Beginning At	San Felipe Rd (Northbound)				San Felipe Rd (Southbound)				Yerba Buena Rd (Eastbound)				Yerba Buena Rd (Westbound)				Total	Hourly Totals
	Left	Thru	Right	U	Left	Thru	Right	U	Left	Thru	Right	U	Left	Thru	Right	U		
7:00 AM	21	26	4	0	8	11	10	0	18	7	9	0	2	10	1	0	127	
7:05 AM	30	24	8	0	4	6	16	1	10	17	11	0	0	10	6	0	143	
7:10 AM	19	20	6	0	1	11	33	0	39	31	6	0	0	13	4	1	184	
7:15 AM	26	41	5	0	6	9	28	0	30	42	11	0	7	12	3	3	223	
7:20 AM	28	35	15	0	14	9	23	0	36	71	12	0	1	21	3	2	270	
7:25 AM	16	20	25	1	17	14	31	0	55	61	5	0	5	28	6	0	284	
7:30 AM	11	24	10	0	20	12	26	1	52	94	7	0	7	37	8	1	310	
7:35 AM	25	23	3	0	37	14	40	1	37	51	8	0	16	34	6	2	297	
7:40 AM	30	21	1	0	29	23	39	0	54	69	8	0	8	50	8	1	341	
7:45 AM	22	31	4	0	14	5	46	1	64	73	11	0	8	29	6	0	314	
7:50 AM	29	54	1	0	13	8	38	0	48	42	16	0	4	12	6	2	273	
7:55 AM	22	51	9	1	18	19	39	0	48	38	8	0	0	15	10	0	278	3044
8:00 AM	16	48	4	1	10	20	38	0	61	35	8	0	2	16	4	1	264	3181
8:05 AM	17	36	1	0	5	7	37	0	54	38	22	0	1	22	3	0	243	3281
8:10 AM	29	38	4	0	11	29	38	0	25	39	12	0	2	11	5	2	245	3342
8:15 AM	11	19	4	0	13	35	49	0	34	27	7	0	5	13	6	2	225	3344
8:20 AM	12	22	2	0	9	29	44	0	39	37	11	0	3	18	3	2	231	3305
8:25 AM	22	24	1	0	24	38	48	1	28	36	14	0	12	6	3	0	257	3278
8:30 AM	16	29	5	0	9	18	32	0	26	27	11	2	4	26	8	1	214	3182
8:35 AM	17	17	5	0	18	22	32	0	31	24	9	0	5	9	7	4	200	3085
8:40 AM	17	23	2	0	20	10	34	0	46	45	9	0	2	20	4	4	236	2980
8:45 AM	19	21	2	0	20	15	34	0	51	81	9	0	4	12	6	1	275	2941
8:50 AM	19	24	2	0	26	20	34	0	44	80	13	0	2	33	10	1	308	2976
8:55 AM	19	33	7	0	33	20	21	1	35	80	18	0	3	36	9	2	317	3015
Peak 15-Min Flowrates	Northbound				Southbound				Eastbound				Westbound				Total	
All Vehicles	308	300	32	0	320	168	500	8	620	772	108	0	128	452	80	12	3808	
Heavy Trucks	8	0	0		0	4	8		4	0	16		0	0	4		44	
Pedestrians	0	0	0		0	20	0		0	4	0		0	0	0		24	
Bicycles	0	0	0		0	0	0		0	0	0		0	0	0		0	
Railroad																		
Stopped Buses																		

Comments: Please conduct vehicular turning movement counts, pedestrian counts, and bicycle counts at this intersection.

LOCATION: San Felipe Rd -- Yerba Buena Rd  
 CITY/STATE: San Jose, CA

QC JOB #: 10653024  
 DATE: Wed, Sep 14 2011

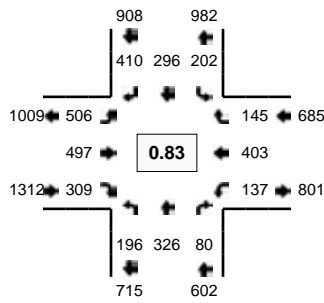

Peak-Hour: 5:00 PM -- 6:00 PM  
 Peak 15-Min: 5:45 PM -- 6:00 PM

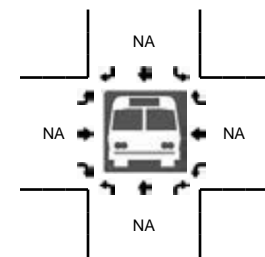
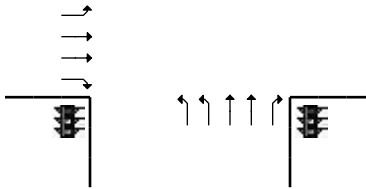
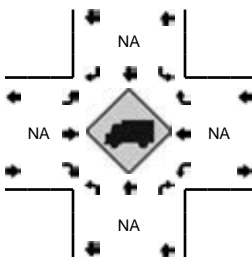
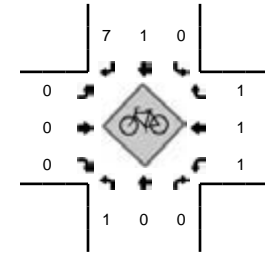
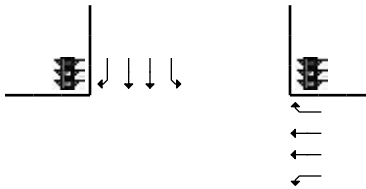
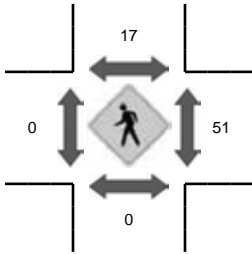
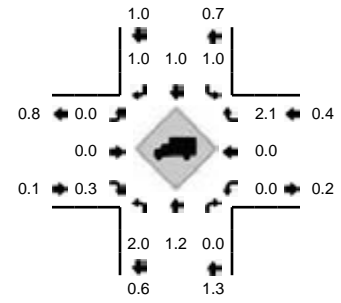

5-Min Count Period Beginning At	San Felipe Rd (Northbound)				San Felipe Rd (Southbound)				Yerba Buena Rd (Eastbound)				Yerba Buena Rd (Westbound)				Total	Hourly Totals
	Left	Thru	Right	U	Left	Thru	Right	U	Left	Thru	Right	U	Left	Thru	Right	U		
4:00 PM	11	27	0	0	4	20	26	0	31	7	21	0	12	16	6	0	181	
4:05 PM	29	22	2	0	5	20	41	0	36	7	20	0	5	23	7	1	218	
4:10 PM	21	28	3	0	2	25	28	0	26	5	22	0	4	39	12	1	216	
4:15 PM	22	19	1	0	5	29	36	1	34	3	26	0	8	26	18	0	228	
4:20 PM	9	17	0	0	6	24	26	0	30	10	25	0	12	12	5	0	176	
4:25 PM	14	17	0	0	7	20	24	0	37	13	31	0	5	9	8	2	187	
4:30 PM	10	22	2	0	4	17	21	1	35	4	16	0	2	36	12	1	183	
4:35 PM	13	20	2	0	7	20	35	1	27	22	16	0	9	23	14	1	210	
4:40 PM	15	22	0	0	10	29	41	2	21	14	26	0	5	39	20	1	245	
4:45 PM	16	16	1	0	7	13	35	0	42	18	19	0	10	27	11	2	217	
4:50 PM	13	21	0	0	12	26	31	0	30	19	24	0	9	18	6	1	210	
4:55 PM	13	23	1	1	7	28	29	0	36	23	24	0	8	31	14	1	239	2510
5:00 PM	17	21	0	0	12	17	40	2	41	17	28	0	11	37	14	3	260	2589
5:05 PM	18	38	3	0	7	29	54	0	36	17	28	0	9	14	9	6	268	2639
5:10 PM	13	14	2	0	7	18	52	1	38	15	32	0	9	50	9	0	260	2683
5:15 PM	18	23	1	0	12	36	35	0	32	20	28	0	5	24	9	0	243	2698
5:20 PM	14	23	3	0	7	26	25	0	52	33	25	0	14	30	9	2	263	2785
5:25 PM	21	21	10	0	22	17	24	0	39	31	23	0	3	38	10	1	260	2858
5:30 PM	21	40	7	0	19	34	25	0	42	22	24	0	10	17	9	2	272	2947
5:35 PM	14	24	9	0	14	17	27	0	55	45	21	0	13	30	9	3	281	3018
5:40 PM	15	22	10	0	22	25	37	0	49	72	21	0	11	50	11	0	345	3118
5:45 PM	19	27	13	0	26	23	26	0	42	65	27	0	5	35	19	5	332	3233
5:50 PM	14	43	12	0	24	26	35	1	38	61	25	0	12	37	22	2	352	3375
5:55 PM	12	30	10	0	25	28	30	1	42	99	27	0	8	41	15	3	371	3507
Peak 15-Min Flowrates	Northbound				Southbound				Eastbound				Westbound				Total	
	Left	Thru	Right	U	Left	Thru	Right	U	Left	Thru	Right	U	Left	Thru	Right	U		
All Vehicles	180	400	140	0	300	308	364	8	488	900	316	0	100	452	224	40	4220	
Heavy Trucks	0	4	0	0	4	0	0	0	0	0	0	0	0	0	4	0	12	
Pedestrians	0	0	0	0	0	32	0	0	0	0	0	0	0	28	0	0	60	
Bicycles	0	0	0	0	0	0	0	0	0	0	0	0	1	0	0	0	1	
Railroad																		
Stopped Buses																		

Comments: Please conduct vehicular turning movement counts, pedestrian counts, and bicycle counts at this intersection.

LOCATION: San Felipe Rd -- Paseo de Arboles  
 CITY/STATE: San Jose, CA

QC JOB #: 10653026  
 DATE: Wed, Sep 14 2011

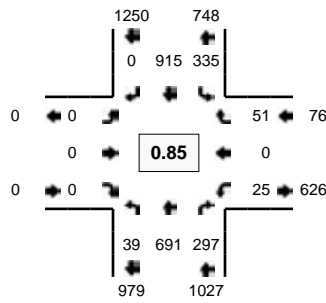

Peak-Hour: 7:25 AM -- 8:25 AM  
 Peak 15-Min: 7:35 AM -- 7:50 AM

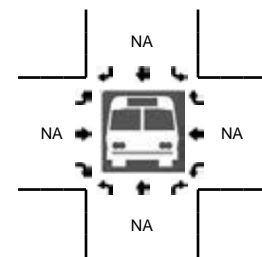
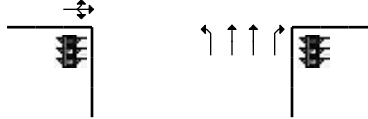
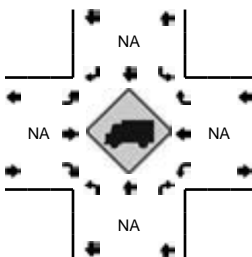
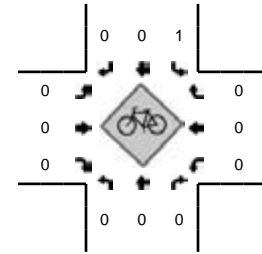
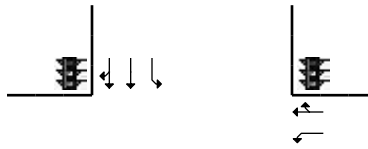
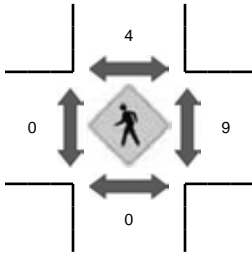
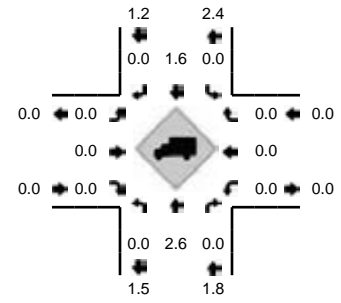

5-Min Count Period Beginning At	San Felipe Rd (Northbound)				San Felipe Rd (Southbound)				Paseo de Arboles (Eastbound)				Paseo de Arboles (Westbound)				Total	Hourly Totals
	Left	Thru	Right	U	Left	Thru	Right	U	Left	Thru	Right	U	Left	Thru	Right	U		
7:00 AM	0	39	8	3	5	22	0	1	0	0	0	0	3	0	0	0	81	
7:05 AM	0	28	6	0	4	30	0	0	0	0	0	0	0	0	2	0	70	
7:10 AM	0	42	14	4	9	52	0	0	2	0	0	0	1	0	3	0	127	
7:15 AM	0	59	9	6	20	43	0	1	0	0	0	0	1	0	1	0	140	
7:20 AM	0	57	15	7	23	50	0	0	0	0	0	0	1	0	2	0	155	
7:25 AM	0	55	23	2	23	61	0	1	0	0	0	0	1	0	3	0	169	
7:30 AM	0	39	29	4	46	70	0	1	0	0	0	0	0	0	5	0	194	
7:35 AM	0	51	31	2	52	85	0	0	0	0	0	0	6	0	7	0	234	
7:40 AM	0	42	45	6	56	91	0	0	0	0	0	0	4	0	9	0	253	
7:45 AM	0	71	38	3	19	62	0	1	0	0	0	0	4	0	5	0	203	
7:50 AM	0	77	27	1	35	64	0	0	0	0	0	0	2	0	2	0	208	
7:55 AM	0	64	28	2	31	66	0	0	0	0	0	0	3	0	7	0	201	2035
8:00 AM	0	101	23	2	24	70	0	1	0	0	0	0	1	0	2	0	224	2178
8:05 AM	0	64	17	5	13	53	0	0	0	0	0	0	2	0	4	0	158	2266
8:10 AM	0	40	13	3	4	69	0	1	0	0	0	0	2	0	1	0	133	2272
8:15 AM	0	42	16	5	14	118	0	0	0	0	0	0	0	0	1	0	196	2328
8:20 AM	0	45	7	4	12	106	0	1	0	0	0	0	0	0	5	0	180	2353
8:25 AM	0	32	9	5	12	95	0	2	0	0	0	0	2	0	2	0	159	2343
8:30 AM	0	47	12	3	13	63	0	1	0	0	0	0	0	0	2	0	141	2290
8:35 AM	0	43	10	5	14	77	0	0	0	0	0	0	1	0	3	0	153	2209
8:40 AM	0	49	21	3	37	76	0	1	0	0	0	0	0	0	3	0	190	2146
8:45 AM	1	32	26	5	41	84	0	0	0	0	0	0	4	0	2	0	195	2138
8:50 AM	0	33	33	4	45	79	0	0	0	0	0	0	3	0	4	0	201	2131
8:55 AM	0	39	43	6	52	67	0	0	0	0	0	0	8	0	7	0	222	2152
Peak 15-Min Flowrates	Northbound				Southbound				Eastbound				Westbound				Total	
All Vehicles	0	656	456	44	508	952	0	4	0	0	0	0	56	0	84	0	2760	
Heavy Trucks	0	8	0		0	12	0		0	0	0	0	0	0	0		20	
Pedestrians	0				0	4			0				8				12	
Bicycles	0	0	0		0	0	0		0	0	0		0	0	0		0	
Railroad																		
Stopped Buses																		

Comments: Please conduct vehicular turning movement counts, pedestrian counts, and bicycle counts at this intersection.

LOCATION: San Felipe Rd -- Paseo de Arboles  
 CITY/STATE: San Jose, CA

QC JOB #: 10653028  
 DATE: Wed, Sep 14 2011

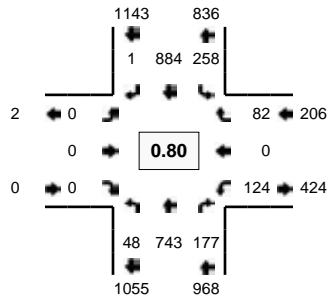

Peak-Hour: 5:00 PM -- 6:00 PM  
 Peak 15-Min: 5:45 PM -- 6:00 PM

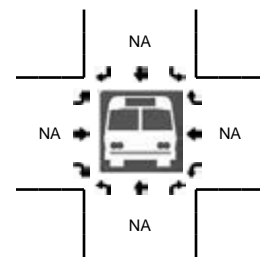
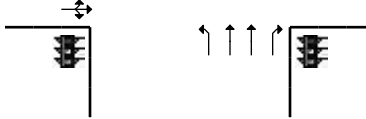
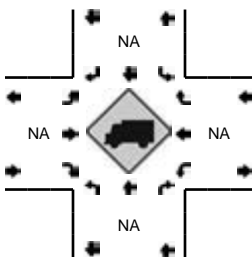
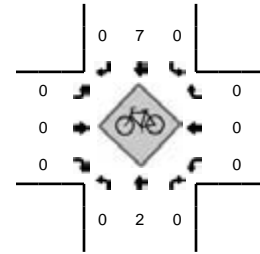
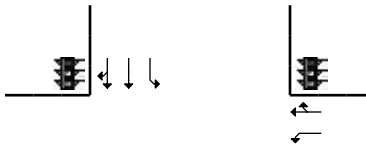
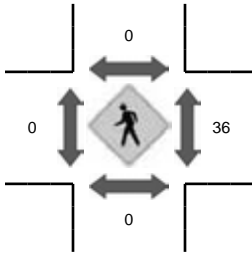
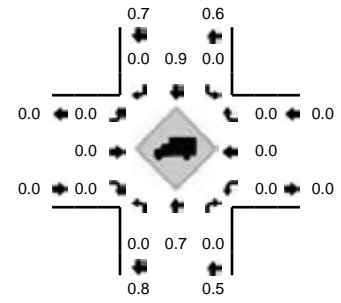

5-Min Count Period Beginning At	San Felipe Rd (Northbound)				San Felipe Rd (Southbound)				Paseo de Arboles (Eastbound)				Paseo de Arboles (Westbound)				Total	Hourly Totals
	Left	Thru	Right	U	Left	Thru	Right	U	Left	Thru	Right	U	Left	Thru	Right	U		
4:00 PM	0	54	3	8	6	62	0	3	0	0	0	0	1	0	10	0	147	
4:05 PM	0	63	1	4	9	56	0	2	0	0	0	0	6	0	7	0	148	
4:10 PM	0	69	3	3	3	55	0	0	0	0	0	0	4	0	7	1	145	
4:15 PM	0	60	5	3	2	70	0	0	0	0	0	0	9	0	0	0	149	
4:20 PM	0	41	5	3	6	57	0	0	0	0	0	0	0	0	6	0	118	
4:25 PM	0	46	12	3	7	52	0	0	0	0	0	0	10	0	5	0	135	
4:30 PM	0	65	3	1	6	59	0	1	0	0	0	0	4	0	9	0	148	
4:35 PM	0	56	4	3	3	63	0	2	0	0	0	0	9	0	16	0	156	
4:40 PM	0	50	4	4	7	58	0	1	0	0	0	0	20	0	15	0	159	
4:45 PM	0	65	5	4	6	73	0	1	0	0	0	0	6	0	15	0	175	
4:50 PM	0	57	6	2	9	61	0	0	0	0	0	0	9	0	12	0	156	
4:55 PM	0	46	7	4	4	67	0	0	0	0	0	0	9	0	6	0	143	1779
5:00 PM	0	49	7	6	8	63	0	1	0	0	0	0	23	0	12	0	169	1801
5:05 PM	1	59	4	8	5	62	0	1	0	0	0	0	25	0	8	0	173	1826
5:10 PM	0	69	8	3	3	69	0	1	0	0	0	0	20	0	8	0	181	1862
5:15 PM	0	47	6	4	16	62	0	1	0	0	0	0	8	0	4	0	148	1861
5:20 PM	0	70	3	2	12	61	0	3	0	0	0	0	7	0	1	0	159	1902
5:25 PM	0	66	8	0	17	76	0	2	0	0	0	0	5	0	2	0	176	1943
5:30 PM	0	59	14	5	13	69	0	0	0	0	0	0	7	0	7	0	174	1969
5:35 PM	0	65	24	4	26	72	0	0	0	0	0	0	6	0	2	0	199	2012
5:40 PM	0	53	20	6	40	86	0	0	0	0	0	0	6	0	7	0	218	2071
5:45 PM	0	59	30	3	32	85	0	2	0	0	0	0	4	0	8	0	223	2119
5:50 PM	0	81	27	4	31	86	0	0	0	0	0	0	5	0	12	0	246	2209
5:55 PM	0	66	26	2	44	93	1	0	0	0	0	0	8	0	11	0	251	2317
Peak 15-Min Flowrates	Northbound				Southbound				Eastbound				Westbound				Total	
All Vehicles	0	824	332	36	428	1056	4	8	0	0	0	0	68	0	124	0	2880	
Heavy Trucks	0	0	0		0	4	0		0	0	0		0	0	0		4	
Pedestrians	0	0	0		0	0			0	0			16	0	0		16	
Bicycles	0	0	0		0	0	0		0	0	0		0	0	0		0	
Railroad																		
Stopped Buses																		

Comments: Please conduct vehicular turning movement counts, pedestrian counts, and bicycle counts at this intersection.

LOCATION: San Felipe Rd -- Delta Rd  
 CITY/STATE: San Jose, CA

QC JOB #: 10653030  
 DATE: Wed, Sep 14 2011

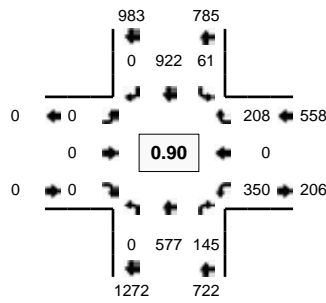

Peak-Hour: 7:25 AM -- 8:25 AM  
 Peak 15-Min: 7:30 AM -- 7:45 AM

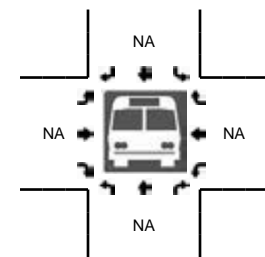
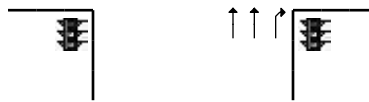
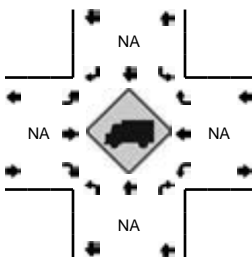
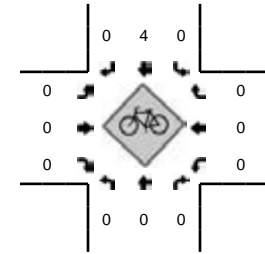
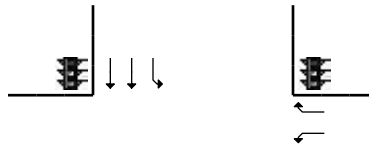
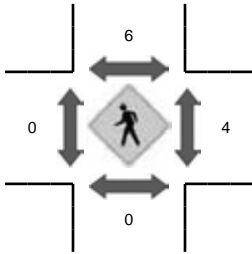
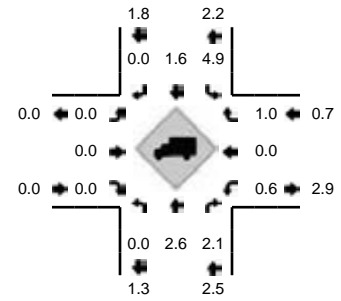

5-Min Count Period Beginning At	San Felipe Rd (Northbound)				San Felipe Rd (Southbound)				Delta Rd (Eastbound)				Delta Rd (Westbound)				Total	Hourly Totals
	Left	Thru	Right	U	Left	Thru	Right	U	Left	Thru	Right	U	Left	Thru	Right	U		
7:00 AM	0	29	6	0	1	23	0	0	0	0	0	0	6	0	9	0	74	
7:05 AM	0	23	12	0	3	24	0	0	0	0	0	0	12	0	12	0	86	
7:10 AM	0	37	10	0	4	41	0	0	0	0	0	0	18	0	14	0	124	
7:15 AM	0	32	22	0	3	37	0	0	0	0	0	0	21	0	12	0	127	
7:20 AM	0	50	18	0	1	56	0	0	0	0	0	0	15	0	15	0	155	
7:25 AM	0	37	20	0	5	60	0	0	0	0	0	0	30	0	21	0	173	
7:30 AM	0	36	13	0	2	122	0	0	0	0	0	0	20	0	22	0	215	
7:35 AM	0	34	8	0	5	105	0	0	0	0	0	0	41	0	14	0	207	
7:40 AM	0	59	6	0	6	83	0	0	0	0	0	0	32	0	18	0	204	
7:45 AM	0	58	18	0	4	86	0	0	0	0	0	0	16	0	15	0	197	
7:50 AM	0	48	11	0	7	59	0	0	0	0	0	0	30	0	15	0	170	
7:55 AM	0	61	13	0	3	62	0	0	0	0	0	0	28	0	17	0	184	1916
8:00 AM	0	77	22	0	2	69	0	0	0	0	0	0	24	0	12	0	206	2048
8:05 AM	0	56	8	0	4	32	0	0	0	0	0	0	35	0	26	0	161	2123
8:10 AM	0	37	10	0	9	67	0	0	0	0	0	0	27	0	17	0	167	2166
8:15 AM	0	35	10	0	5	85	0	0	0	0	0	0	33	0	10	0	178	2217
8:20 AM	0	39	6	0	9	92	0	0	0	0	0	0	34	0	21	0	201	2263
8:25 AM	0	35	5	0	3	68	0	0	0	0	0	0	33	0	14	0	158	2248
8:30 AM	0	41	9	0	2	64	0	0	0	0	0	0	19	0	13	0	148	2181
8:35 AM	0	31	8	0	4	70	0	0	0	0	0	0	23	0	17	0	153	2127
8:40 AM	0	36	14	0	4	72	0	0	0	0	0	0	39	0	20	0	185	2108
8:45 AM	0	32	5	0	8	98	0	0	1	0	0	0	25	0	9	0	178	2089
8:50 AM	0	32	6	0	4	136	0	0	0	0	0	0	24	0	14	0	216	2135
8:55 AM	0	39	8	0	1	118	0	0	0	0	0	0	25	0	15	0	206	2157
Peak 15-Min Flowrates	Northbound				Southbound				Eastbound				Westbound				Total	
All Vehicles	0	516	108	0	52	1240	0	0	0	0	0	0	372	0	216	0	2504	
Heavy Trucks	0	8	8		0	12	0		0	0	0		4	0	4		36	
Pedestrians	0	0	0		0	4	0		0	0	0		0	0	0		4	
Bicycles	0	0	0		0	0	0		0	0	0		0	0	0		0	
Railroad																		
Stopped Buses																		

Comments: Please conduct vehicular turning movement counts, pedestrian counts, and bicycle counts at this intersection.

LOCATION: San Felipe Rd -- Delta Rd  
 CITY/STATE: San Jose, CA

QC JOB #: 10653032  
 DATE: Wed, Sep 14 2011

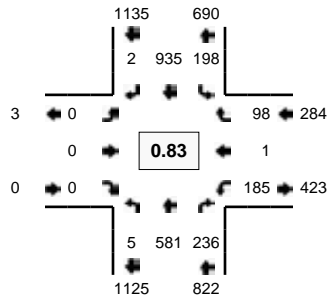

Peak-Hour: 5:00 PM -- 6:00 PM  
 Peak 15-Min: 5:45 PM -- 6:00 PM

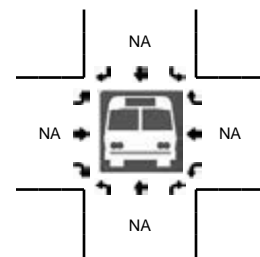
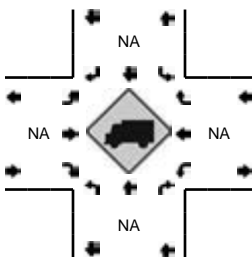
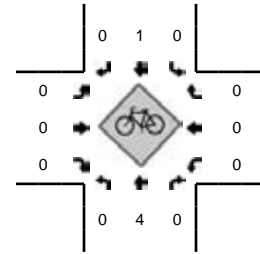
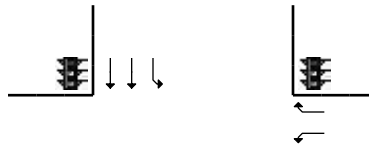
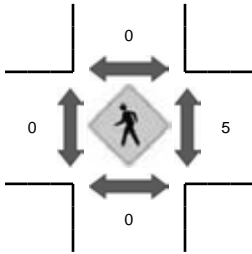
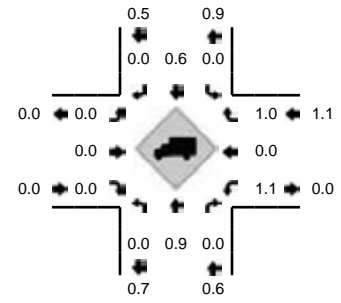

5-Min Count Period Beginning At	San Felipe Rd (Northbound)				San Felipe Rd (Southbound)				Delta Rd (Eastbound)				Delta Rd (Westbound)				Total	Hourly Totals
	Left	Thru	Right	U	Left	Thru	Right	U	Left	Thru	Right	U	Left	Thru	Right	U		
4:00 PM	0	41	19	0	11	52	0	0	0	0	0	0	6	0	7	0	136	
4:05 PM	1	52	14	0	14	57	0	0	0	0	0	0	19	0	5	0	162	
4:10 PM	0	61	19	0	9	44	0	0	0	0	0	0	18	0	9	0	160	
4:15 PM	0	48	14	0	8	56	0	0	0	0	0	0	11	0	4	0	141	
4:20 PM	0	38	6	0	9	46	0	0	0	0	0	0	8	0	6	0	113	
4:25 PM	0	37	8	0	10	45	0	0	1	0	0	0	13	0	7	0	121	
4:30 PM	0	47	23	0	11	50	0	0	0	0	0	0	12	0	9	0	152	
4:35 PM	0	55	14	0	15	52	0	0	0	0	0	0	13	0	5	0	154	
4:40 PM	0	72	7	0	6	65	0	0	0	0	0	0	10	0	4	0	164	
4:45 PM	0	50	21	0	12	64	0	0	0	0	0	0	10	0	7	0	164	
4:50 PM	0	41	18	0	14	59	0	0	0	0	0	0	20	0	7	0	159	
4:55 PM	0	55	12	0	9	61	0	0	0	0	0	0	9	0	13	0	159	1785
5:00 PM	0	47	18	0	11	43	0	0	0	0	0	0	14	0	8	0	141	1790
5:05 PM	0	50	23	1	9	69	0	1	0	0	0	0	18	0	7	0	178	1806
5:10 PM	0	49	24	2	12	52	0	1	0	0	0	0	11	0	11	0	162	1808
5:15 PM	0	31	19	0	16	60	1	2	0	0	0	0	19	0	6	0	154	1821
5:20 PM	0	52	20	0	21	59	0	1	0	0	0	0	16	0	5	0	174	1882
5:25 PM	0	28	23	0	25	76	0	0	0	0	0	0	18	0	8	0	178	1939
5:30 PM	0	60	16	1	17	82	1	0	0	0	0	0	17	0	12	0	206	1993
5:35 PM	0	45	15	0	14	64	0	0	0	0	0	0	15	1	10	0	164	2003
5:40 PM	0	39	20	0	19	107	0	2	0	0	0	0	17	0	5	0	209	2048
5:45 PM	0	43	15	0	12	102	0	2	0	0	0	0	15	0	10	0	199	2083
5:50 PM	0	66	22	0	9	110	0	1	0	0	0	0	17	0	6	0	231	2155
5:55 PM	0	71	21	1	22	111	0	1	0	0	0	0	8	0	10	0	245	2241
Peak 15-Min Flowrates	Northbound				Southbound				Eastbound				Westbound				Total	
	Left	Thru	Right	U	Left	Thru	Right	U	Left	Thru	Right	U	Left	Thru	Right	U		
All Vehicles	0	720	232	4	172	1292	0	16	0	0	0	0	160	0	104	0	2700	
Heavy Trucks	0	4	0		0	4	0		0	0	0		0	0	0		8	
Pedestrians	0				0				0				8				8	
Bicycles	0	0	0		0	0	0		0	0	0		0	0	0		0	
Railroad																		
Stopped Buses																		

Comments: Please conduct vehicular turning movement counts, pedestrian counts, and bicycle counts at this intersection.

LOCATION: San Felipe Rd -- Fowler Rd  
 CITY/STATE: San Jose, CA

QC JOB #: 10653034  
 DATE: Wed, Sep 14 2011

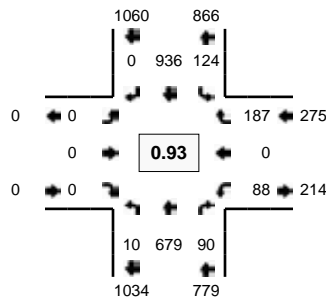

Peak-Hour: 8:00 AM -- 9:00 AM  
 Peak 15-Min: 8:10 AM -- 8:25 AM

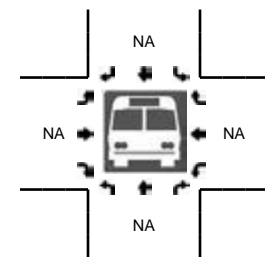
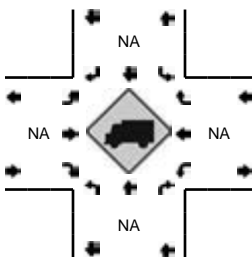
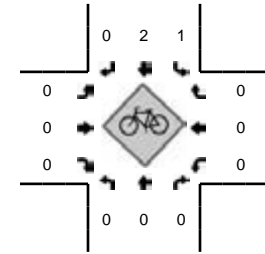
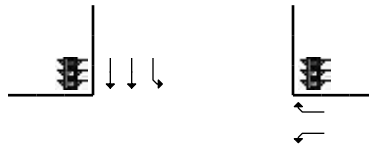
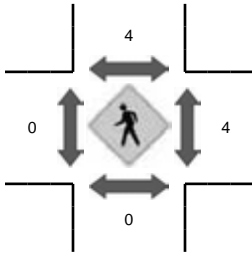
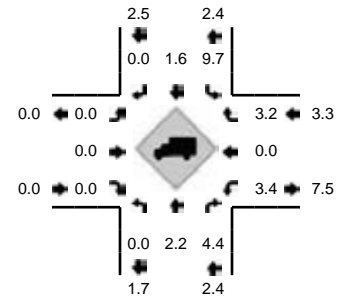

5-Min Count Period Beginning At	San Felipe Rd (Northbound)				San Felipe Rd (Southbound)				Fowler Rd (Eastbound)				Fowler Rd (Westbound)				Total	Hourly Totals
	Left	Thru	Right	U	Left	Thru	Right	U	Left	Thru	Right	U	Left	Thru	Right	U		
7:00 AM	0	31	0	0	0	23	0	0	0	0	0	0	2	0	8	0	64	
7:05 AM	0	45	0	0	2	24	0	0	0	0	0	0	4	0	8	0	83	
7:10 AM	0	48	4	0	2	40	0	0	0	0	0	0	6	0	7	0	107	
7:15 AM	0	47	4	0	6	44	0	0	0	0	0	0	4	0	14	0	119	
7:20 AM	0	44	9	0	10	56	0	0	0	0	0	0	12	0	9	0	140	
7:25 AM	0	72	2	0	2	50	0	0	0	0	0	0	10	0	10	0	146	
7:30 AM	0	53	3	0	7	121	0	0	0	0	0	0	12	0	9	0	205	
7:35 AM	0	47	4	1	3	102	0	0	0	0	0	0	11	0	9	0	177	
7:40 AM	0	66	6	0	4	71	0	0	0	0	0	0	9	0	13	0	169	
7:45 AM	0	65	0	0	2	63	0	0	0	0	0	0	11	0	9	0	150	
7:50 AM	0	78	4	0	6	75	0	0	0	0	0	0	8	0	9	0	180	
7:55 AM	0	58	6	0	6	49	0	0	0	0	0	0	11	0	12	0	142	1682
8:00 AM	0	87	9	2	11	53	0	0	0	0	0	0	5	0	9	0	176	1794
8:05 AM	0	85	11	0	12	47	0	0	0	0	0	0	5	0	10	0	170	1881
8:10 AM	0	53	16	1	23	61	0	0	0	0	0	0	7	0	17	0	178	1952
8:15 AM	0	47	11	2	20	73	0	0	0	0	0	0	8	0	14	0	175	2008
8:20 AM	0	66	15	0	14	101	0	0	0	0	0	0	6	0	14	0	216	2084
8:25 AM	0	53	3	2	8	53	0	0	0	0	0	0	10	0	31	0	160	2098
8:30 AM	0	58	2	0	4	53	0	0	0	0	0	0	10	0	34	0	161	2054
8:35 AM	0	40	9	0	7	69	0	0	0	0	0	0	8	0	15	0	148	2025
8:40 AM	0	53	6	1	6	84	0	0	0	0	0	0	9	0	7	0	166	2022
8:45 AM	0	49	3	1	8	84	0	0	0	0	0	0	7	0	12	0	164	2036
8:50 AM	0	35	4	0	7	137	0	0	0	0	0	0	4	0	12	0	199	2055
8:55 AM	0	53	1	1	4	121	0	0	0	0	0	0	9	0	12	0	201	2114
Peak 15-Min Flowrates	Northbound				Southbound				Eastbound				Westbound				Total	
All Vehicles	0	664	168	12	228	940	0	0	0	0	0	0	84	0	180	0	2276	
Heavy Trucks	0	12	12		0	32	0		0	0	0		0	0	4		60	
Pedestrians	0	0	0		0	0	0		0	0	0		0	0	0		0	
Bicycles	0	0	0		1	1	0		0	0	0		0	0	0		2	
Railroad																		
Stopped Buses																		

Comments: Please conduct vehicular turning movement counts, pedestrian counts, and bicycle counts at this intersection.

LOCATION: San Felipe Rd -- Fowler Rd  
 CITY/STATE: San Jose, CA

QC JOB #: 10653036  
 DATE: Wed, Sep 14 2011

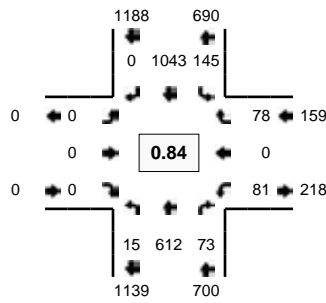

Peak-Hour: 5:00 PM -- 6:00 PM  
 Peak 15-Min: 5:45 PM -- 6:00 PM

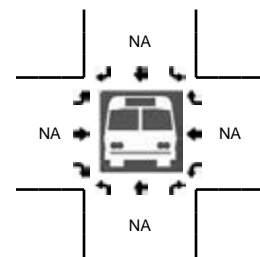
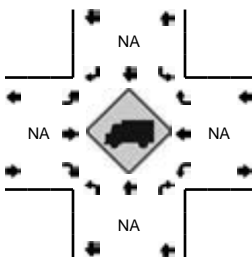
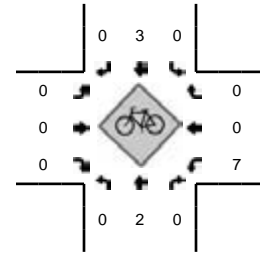
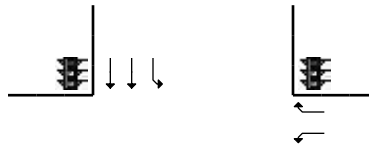
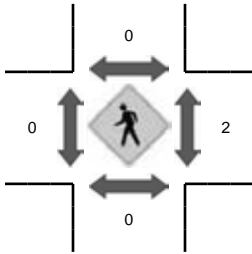
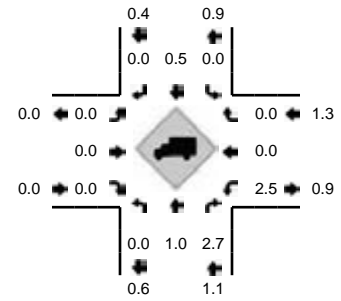

5-Min Count Period Beginning At	San Felipe Rd (Northbound)				San Felipe Rd (Southbound)				Fowler Rd (Eastbound)				Fowler Rd (Westbound)				Total	Hourly Totals
	Left	Thru	Right	U	Left	Thru	Right	U	Left	Thru	Right	U	Left	Thru	Right	U		
4:00 PM	0	44	3	1	4	63	0	0	0	0	0	0	6	0	4	0	125	
4:05 PM	0	53	6	0	10	62	0	0	0	0	0	0	4	0	8	0	143	
4:10 PM	0	57	2	1	0	54	0	0	0	0	0	0	4	0	3	0	121	
4:15 PM	0	53	4	1	8	54	0	0	0	0	0	0	6	0	4	0	130	
4:20 PM	0	47	6	0	5	61	0	0	0	0	0	0	5	0	5	0	129	
4:25 PM	0	40	5	0	8	53	0	0	0	0	0	0	3	0	10	0	119	
4:30 PM	0	55	3	1	10	53	0	0	0	0	0	0	8	0	12	0	142	
4:35 PM	0	61	4	0	9	61	0	0	0	0	0	0	7	0	3	0	145	
4:40 PM	0	64	0	1	5	68	0	0	0	0	0	0	3	0	6	0	147	
4:45 PM	0	64	4	1	7	74	0	0	0	0	0	0	3	0	5	0	158	
4:50 PM	0	51	4	1	7	66	0	0	0	0	0	0	2	0	10	0	141	
4:55 PM	0	57	7	0	8	59	0	0	0	0	0	0	5	0	4	0	140	1640
5:00 PM	0	52	4	0	5	74	0	0	0	0	0	0	6	0	3	0	144	1659
5:05 PM	0	57	3	0	13	61	0	0	0	0	0	0	8	0	4	0	146	1662
5:10 PM	0	57	4	0	8	55	0	0	0	0	0	0	3	0	6	0	133	1674
5:15 PM	0	27	7	0	12	66	0	0	0	0	0	0	8	0	6	0	126	1670
5:20 PM	0	48	10	1	12	85	0	0	0	0	0	0	5	0	9	0	170	1711
5:25 PM	0	41	2	2	16	87	0	0	0	0	0	0	10	0	15	0	173	1765
5:30 PM	0	58	5	1	11	94	0	0	0	0	0	0	7	0	8	0	184	1807
5:35 PM	0	57	8	1	14	97	0	0	0	0	0	0	5	0	10	0	192	1854
5:40 PM	0	40	8	3	12	88	0	0	0	0	0	0	12	0	5	0	168	1875
5:45 PM	0	48	7	3	12	109	0	0	0	0	0	0	5	0	5	0	189	1906
5:50 PM	0	64	6	1	16	120	0	0	0	0	0	0	7	0	4	0	218	1983
5:55 PM	0	63	9	3	14	107	0	0	0	0	0	0	5	0	3	0	204	2047
Peak 15-Min Flowrates	Northbound				Southbound				Eastbound				Westbound				Total	
	Left	Thru	Right	U	Left	Thru	Right	U	Left	Thru	Right	U	Left	Thru	Right	U		
All Vehicles	0	700	88	28	168	1344	0	0	0	0	0	0	68	0	48	0	2444	
Heavy Trucks	0	0	4		0	4	0		0	0	0		0	0	0		8	
Pedestrians	0	0	0		0	0	0		0	0	0		0	0	0		0	
Bicycles	0	0	0		0	0	0		0	0	0		0	0	0		0	
Railroad																		
Stopped Buses																		

Comments: Please conduct vehicular turning movement counts, pedestrian counts, and bicycle counts at this intersection.



**LOCATION:** San Felipe Rd -- Yerba Buena Ave  
**CITY/STATE:** San Jose, CA

**QC JOB #:** 10653038  
**DATE:** Wed, Sep 14 2011

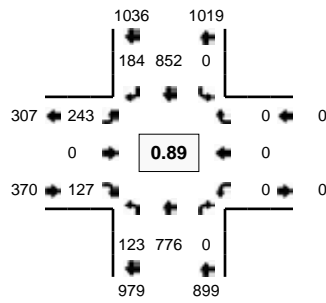

**Peak-Hour: 7:30 AM -- 8:30 AM**  
**Peak 15-Min: 8:10 AM -- 8:25 AM**

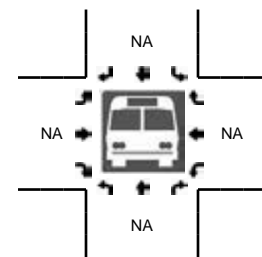
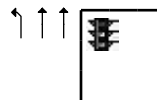
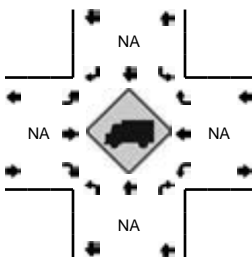
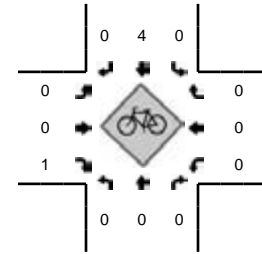
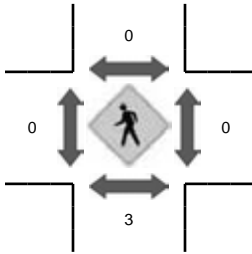
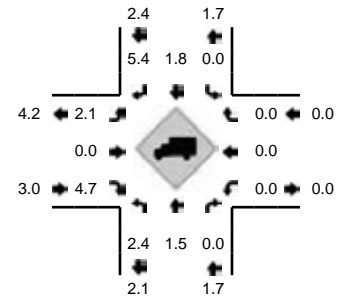

5-Min Count Period Beginning At	San Felipe Rd (Northbound)				San Felipe Rd (Southbound)				Yerba Buena Ave (Eastbound)				Yerba Buena Ave (Westbound)				Total	Hourly Totals
	Left	Thru	Right	U	Left	Thru	Right	U	Left	Thru	Right	U	Left	Thru	Right	U		
7:00 AM	2	45	0	0	0	19	6	0	9	0	2	0	0	0	0	0	83	
7:05 AM	2	47	0	0	0	20	5	0	14	0	6	0	0	0	0	0	94	
7:10 AM	1	53	0	0	0	34	3	0	13	0	6	0	0	0	1	0	111	
7:15 AM	4	53	0	0	0	43	6	0	11	0	3	0	0	0	0	0	120	
7:20 AM	4	58	0	0	0	59	5	0	16	0	14	0	0	0	0	0	156	
7:25 AM	5	67	0	0	0	48	5	0	18	0	8	0	0	0	0	0	151	
7:30 AM	3	63	0	0	0	109	4	0	14	0	4	0	0	0	0	0	197	
7:35 AM	4	47	0	0	0	108	4	0	12	0	8	0	0	0	0	0	183	
7:40 AM	4	78	0	0	0	69	7	0	11	0	6	0	0	0	0	0	175	
7:45 AM	4	56	0	0	0	57	23	0	11	0	4	0	0	0	0	0	155	
7:50 AM	7	81	0	0	0	71	19	0	10	0	6	0	0	0	0	0	194	
7:55 AM	9	67	0	0	0	66	18	0	23	0	4	0	0	0	0	0	187	1806
8:00 AM	20	51	0	0	0	46	24	0	19	0	0	0	0	0	0	0	160	1883
8:05 AM	33	66	0	0	0	51	28	0	19	0	9	0	0	0	0	0	206	1995
8:10 AM	22	67	0	0	0	65	20	0	34	0	14	0	0	0	0	0	222	2106
8:15 AM	9	51	0	0	0	71	13	0	31	0	25	0	0	0	0	0	200	2186
8:20 AM	3	67	0	0	0	82	10	0	29	0	32	0	0	0	0	0	223	2253
8:25 AM	5	82	0	0	0	57	14	0	30	0	15	0	0	0	0	0	203	2305
8:30 AM	10	80	0	0	0	50	7	0	17	0	7	0	0	0	0	0	171	2279
8:35 AM	4	53	0	0	0	68	7	0	22	0	9	0	0	0	0	0	163	2259
8:40 AM	1	54	0	0	0	85	11	0	9	0	4	0	0	0	0	0	164	2248
8:45 AM	1	56	0	0	0	95	9	0	11	0	8	0	0	0	0	0	180	2273
8:50 AM	2	46	0	0	0	116	8	0	13	0	7	0	0	0	0	0	192	2271
8:55 AM	4	57	0	0	0	119	5	0	13	0	6	0	0	0	0	0	204	2288
Peak 15-Min Flowrates	Northbound				Southbound				Eastbound				Westbound				Total	
All Vehicles	136	740	0	0	0	872	172	0	376	0	284	0	0	0	0	0	2580	
Heavy Trucks	4	16	0	0	0	20	8	0	8	0	16	0	0	0	0	0	72	
Pedestrians	0	0	0	0	0	0	0	0	0	0	0	0	0	0	0	0	0	
Bicycles	0	0	0	0	0	1	0	0	0	0	0	0	0	0	0	0	1	
Railroad																		
Stopped Buses																		

Comments: Please conduct vehicular turning movement counts, pedestrian counts, and bicycle counts at this intersection.

**LOCATION:** San Felipe Rd -- Yerba Buena Ave  
**CITY/STATE:** San Jose, CA

**QC JOB #:** 10653040  
**DATE:** Wed, Sep 14 2011

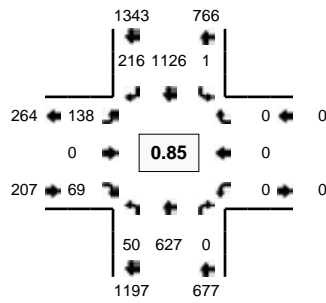

**Peak-Hour: 5:00 PM -- 6:00 PM**  
**Peak 15-Min: 5:45 PM -- 6:00 PM**

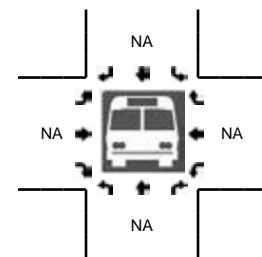
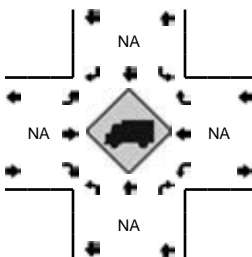
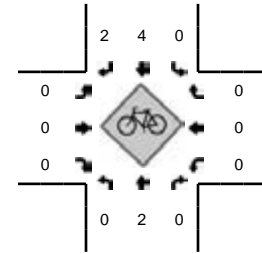
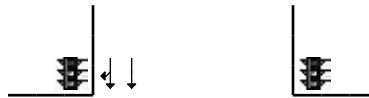
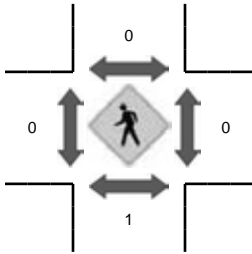
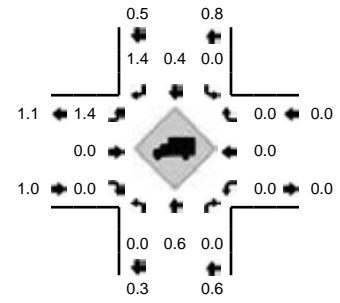

5-Min Count Period Beginning At	San Felipe Rd (Northbound)				San Felipe Rd (Southbound)				Yerba Buena Ave (Eastbound)				Yerba Buena Ave (Westbound)				Total	Hourly Totals
	Left	Thru	Right	U	Left	Thru	Right	U	Left	Thru	Right	U	Left	Thru	Right	U		
4:00 PM	3	53	0	0	0	64	19	0	18	0	3	0	0	0	0	0	160	
4:05 PM	2	48	0	0	0	64	15	0	6	0	5	0	0	0	0	0	140	
4:10 PM	4	73	0	0	0	51	15	0	7	0	3	0	0	0	0	0	153	
4:15 PM	3	39	0	0	0	60	16	0	15	0	4	0	0	0	0	0	137	
4:20 PM	4	57	0	0	0	62	21	0	6	0	5	0	0	0	0	0	155	
4:25 PM	5	45	0	0	0	52	9	0	8	0	5	0	0	0	0	0	124	
4:30 PM	2	56	0	0	0	56	18	0	11	0	6	0	0	0	0	0	149	
4:35 PM	4	62	0	0	0	69	19	0	5	0	4	0	0	0	0	0	163	
4:40 PM	4	59	0	0	0	72	15	0	12	0	4	0	0	0	0	0	166	
4:45 PM	4	77	0	0	0	73	9	0	8	0	6	0	0	0	0	0	177	
4:50 PM	3	54	0	0	0	76	22	0	7	0	1	0	0	0	0	0	163	
4:55 PM	3	59	0	0	0	63	19	0	9	0	4	0	0	0	0	0	157	1844
5:00 PM	2	52	0	0	0	65	13	0	12	0	9	0	0	0	0	0	153	1837
5:05 PM	1	55	0	1	0	72	15	0	8	0	5	0	0	0	0	0	157	1854
5:10 PM	7	64	0	0	0	60	16	0	10	0	3	0	0	0	0	0	160	1861
5:15 PM	1	37	0	0	0	75	23	0	12	0	1	0	0	0	0	0	149	1873
5:20 PM	4	42	0	0	0	91	13	0	13	0	6	0	0	0	0	0	169	1887
5:25 PM	4	47	0	0	0	99	18	0	10	0	3	0	0	0	0	0	181	1944
5:30 PM	6	64	0	0	0	102	20	0	13	0	3	0	0	0	0	0	208	2003
5:35 PM	3	55	0	1	0	95	20	0	9	0	5	0	0	0	0	0	188	2028
5:40 PM	6	41	0	0	0	108	14	0	23	0	12	0	0	0	0	0	204	2066
5:45 PM	2	49	0	0	0	110	22	0	4	0	8	0	0	0	0	0	195	2084
5:50 PM	6	54	0	0	0	128	24	1	12	0	9	0	0	0	0	0	234	2155
5:55 PM	6	67	0	0	0	121	18	0	12	0	5	0	0	0	0	0	229	2227
Peak 15-Min Flowrates	Northbound				Southbound				Eastbound				Westbound				Total	
	Left	Thru	Right	U	Left	Thru	Right	U	Left	Thru	Right	U	Left	Thru	Right	U		
All Vehicles	56	680	0	0	0	1436	256	4	112	0	88	0	0	0	0	0	2632	
Heavy Trucks	0	0	0	0	0	4	4	0	0	0	0	0	0	0	0	0	8	
Pedestrians	0	4	0	0	0	0	0	0	0	0	0	0	0	0	0	0	4	
Bicycles	0	1	0	0	0	0	1	0	0	0	0	0	0	0	0	0	2	
Railroad																		
Stopped Buses																		

*Comments:* Please conduct vehicular turning movement counts, pedestrian counts, and bicycle counts at this intersection.

LOCATION: San Felipe Rd -- Aborn Rd  
 CITY/STATE: San Jose, CA

QC JOB #: 10653042  
 DATE: Wed, Sep 14 2011

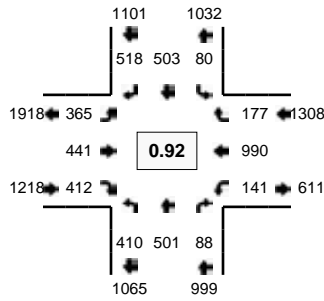

Peak-Hour: 7:30 AM -- 8:30 AM  
 Peak 15-Min: 8:05 AM -- 8:20 AM

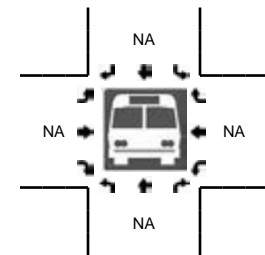
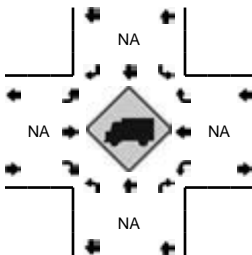
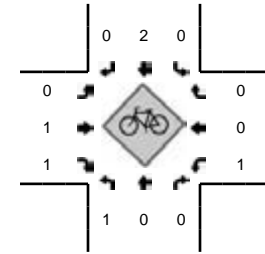
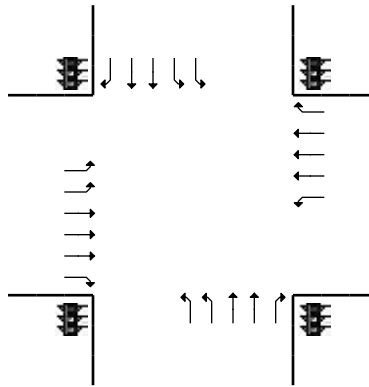
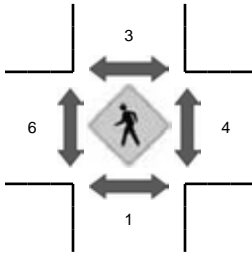
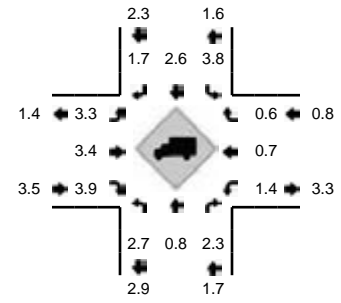

5-Min Count Period Beginning At	San Felipe Rd (Northbound)				San Felipe Rd (Southbound)				Aborn Rd (Eastbound)				Aborn Rd (Westbound)				Total	Hourly Totals
	Left	Thru	Right	U	Left	Thru	Right	U	Left	Thru	Right	U	Left	Thru	Right	U		
7:00 AM	21	18	0	0	2	13	29	0	11	16	11	1	4	42	2	0	170	
7:05 AM	24	29	1	0	2	6	22	1	8	26	15	1	1	76	8	0	220	
7:10 AM	39	22	6	1	3	17	19	1	22	30	18	1	0	61	9	2	251	
7:15 AM	42	29	6	0	4	29	21	0	18	40	27	1	10	74	12	1	314	
7:20 AM	20	28	12	0	2	20	20	0	30	49	20	0	4	84	12	0	301	
7:25 AM	27	35	7	1	4	26	14	1	12	49	27	1	5	84	17	0	310	
7:30 AM	50	48	4	3	4	73	33	0	28	30	59	0	0	75	13	0	420	
7:35 AM	25	24	6	1	4	43	26	0	24	20	30	2	20	88	14	0	327	
7:40 AM	25	39	7	1	6	31	32	1	24	33	40	2	6	115	14	0	376	
7:45 AM	37	60	9	1	9	36	37	0	27	26	27	2	6	54	18	0	349	
7:50 AM	18	48	4	0	6	56	57	0	24	34	41	2	10	72	15	1	388	
7:55 AM	29	32	10	1	1	31	43	0	43	60	33	0	8	90	16	0	397	3823
8:00 AM	35	33	11	2	11	26	40	0	36	61	35	1	7	72	23	0	393	4046
8:05 AM	32	42	11	2	5	50	52	0	39	29	28	2	14	81	17	1	405	4231
8:10 AM	29	43	7	0	6	29	62	1	39	39	30	1	23	98	11	1	419	4399
8:15 AM	34	46	4	4	10	42	63	0	25	33	46	0	13	91	16	1	428	4513
8:20 AM	35	46	7	3	3	57	35	3	20	30	27	1	11	70	8	0	356	4568
8:25 AM	43	40	8	0	8	29	38	2	18	46	16	5	14	84	12	5	368	4626
8:30 AM	36	49	6	0	4	21	15	0	15	40	21	1	11	101	7	2	329	4535
8:35 AM	55	51	10	2	5	44	22	0	14	22	32	1	9	64	11	0	342	4550
8:40 AM	30	37	3	1	5	43	28	1	15	29	39	0	16	68	9	2	326	4500
8:45 AM	23	26	2	0	4	44	25	1	18	41	58	2	7	118	13	0	382	4533
8:50 AM	36	48	1	0	2	59	24	0	6	28	58	1	15	80	9	0	367	4512
8:55 AM	18	34	6	2	6	79	19	0	20	21	35	4	22	78	12	3	359	4474
Peak 15-Min Flowrates	Northbound				Southbound				Eastbound				Westbound				Total	
All Vehicles	380	524	88	24	84	484	708	4	412	404	416	12	200	1080	176	12	5008	
Heavy Trucks	16	4	0		4	12	8		16	20	20		0	16	0		116	
Pedestrians	0	0	0		0	8			0	12			0	4			24	
Bicycles	0	0	0		0	1	0		0	0	1		0	0	0		2	
Railroad																		
Stopped Buses																		

Comments: Please conduct vehicular turning movement counts, pedestrian counts, and bicycle counts at this intersection.

# Traffic Data Service

Campbell, CA  
(408) 377-2988  
tdsbay@cs.com

File Name : 1PM FINAL  
Site Code : 00000001  
Start Date : 10/25/2011  
Page No : 1

### Groups Printed- Vehicles

Start Time	WHITE RD Southbound					ABORN RD Westbound					WHITE RD Northbound					ABORN RD Eastbound					Int. Total
	Left	Thru	Right	Peds	App. Total	Left	Thru	Right	Peds	App. Total	Left	Thru	Right	Peds	App. Total	Left	Thru	Right	Peds	App. Total	
04:00 PM	28	106	92	9	235	60	141	25	0	226	78	95	16	1	190	120	157	83	1	361	1012
04:15 PM	39	122	91	0	252	56	93	27	1	177	74	112	12	0	198	127	118	99	0	344	971
04:30 PM	38	104	90	4	236	48	108	24	0	180	106	100	23	2	231	121	163	101	7	392	1039
04:45 PM	37	126	85	8	256	68	127	36	4	235	71	87	25	2	185	115	171	96	5	387	1063
<b>Total</b>	<b>142</b>	<b>458</b>	<b>358</b>	<b>21</b>	<b>979</b>	<b>232</b>	<b>469</b>	<b>112</b>	<b>5</b>	<b>818</b>	<b>329</b>	<b>394</b>	<b>76</b>	<b>5</b>	<b>804</b>	<b>483</b>	<b>609</b>	<b>379</b>	<b>13</b>	<b>1484</b>	<b>4085</b>
05:00 PM	56	151	74	2	283	37	114	32	0	183	113	139	18	0	270	95	149	88	1	333	1069
05:15 PM	35	154	65	0	254	65	134	31	0	230	86	102	12	1	201	118	208	119	2	447	1132
05:30 PM	32	201	85	5	323	70	128	27	1	226	78	118	21	2	219	129	159	113	3	404	1172
05:45 PM	51	193	99	0	343	77	121	30	0	228	102	135	33	5	275	115	218	127	1	461	1307
<b>Total</b>	<b>174</b>	<b>699</b>	<b>323</b>	<b>7</b>	<b>1203</b>	<b>249</b>	<b>497</b>	<b>120</b>	<b>1</b>	<b>867</b>	<b>379</b>	<b>494</b>	<b>84</b>	<b>8</b>	<b>965</b>	<b>457</b>	<b>734</b>	<b>447</b>	<b>7</b>	<b>1645</b>	<b>4680</b>
<b>Grand Total</b>	<b>316</b>	<b>1157</b>	<b>681</b>	<b>28</b>	<b>2182</b>	<b>481</b>	<b>966</b>	<b>232</b>	<b>6</b>	<b>1685</b>	<b>708</b>	<b>888</b>	<b>160</b>	<b>13</b>	<b>1769</b>	<b>940</b>	<b>1343</b>	<b>826</b>	<b>20</b>	<b>3129</b>	<b>8765</b>
Apprch %	14.5	53	31.2	1.3		28.5	57.3	13.8	0.4		40	50.2	9	0.7		30	42.9	26.4	0.6		
Total %	3.6	13.2	7.8	0.3	24.9	5.5	11	2.6	0.1	19.2	8.1	10.1	1.8	0.1	20.2	10.7	15.3	9.4	0.2	35.7	

Start Time	WHITE RD Southbound					ABORN RD Westbound					WHITE RD Northbound					ABORN RD Eastbound					Int. Total
	Left	Thru	Right	Peds	App. Total	Left	Thru	Right	Peds	App. Total	Left	Thru	Right	Peds	App. Total	Left	Thru	Right	Peds	App. Total	
Peak Hour Analysis From 04:00 PM to 05:45 PM - Peak 1 of 1																					
Peak Hour for Entire Intersection Begins at 05:00 PM																					
05:00 PM	56	151	74	2	283	37	114	32	0	183	113	139	18	0	270	95	149	88	1	333	1069
05:15 PM	35	154	65	0	254	65	134	31	0	230	86	102	12	1	201	118	208	119	2	447	1132
05:30 PM	32	201	85	5	323	70	128	27	1	226	78	118	21	2	219	129	159	113	3	404	1172
05:45 PM	51	193	99	0	343	77	121	30	0	228	102	135	33	5	275	115	218	127	1	461	1307
<b>Total Volume</b>	<b>174</b>	<b>699</b>	<b>323</b>	<b>7</b>	<b>1203</b>	<b>249</b>	<b>497</b>	<b>120</b>	<b>1</b>	<b>867</b>	<b>379</b>	<b>494</b>	<b>84</b>	<b>8</b>	<b>965</b>	<b>457</b>	<b>734</b>	<b>447</b>	<b>7</b>	<b>1645</b>	<b>4680</b>
% App. Total	14.5	58.1	26.8	0.6		28.7	57.3	13.8	0.1		39.3	51.2	8.7	0.8		27.8	44.6	27.2	0.4		
PHF	.777	.869	.816	.350	.877	.808	.927	.938	.250	.942	.838	.888	.636	.400	.877	.886	.842	.880	.583	.892	.895

# Traffic Data Service

Campbell, CA

(408) 377-2988

tdsbay@cs.com

File Name : 1PM FINAL

Site Code : 00000001

Start Date : 10/25/2011

Page No : 2

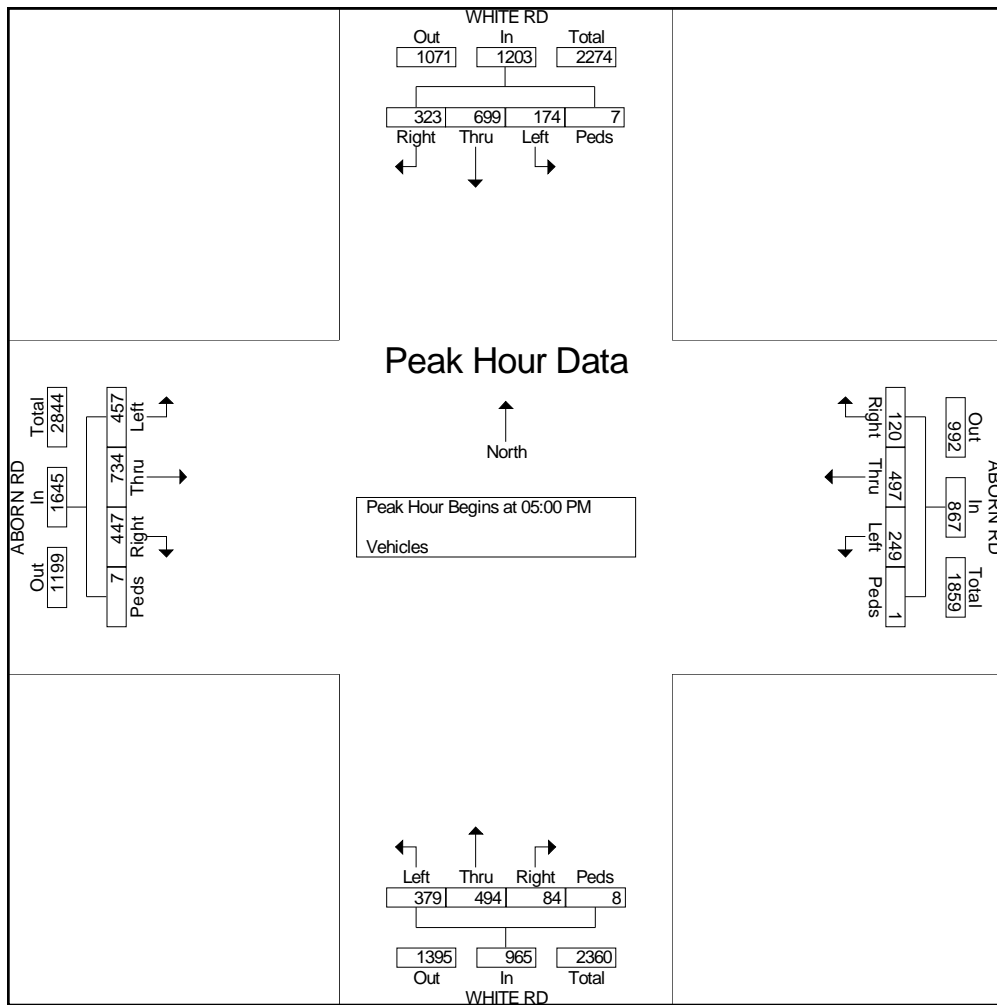

**LOCATION:** Nieman Blvd -- Aborn Rd  
**CITY/STATE:** San Jose, CA

**QC JOB #:** 10653046  
**DATE:** Wed, Sep 14 2011

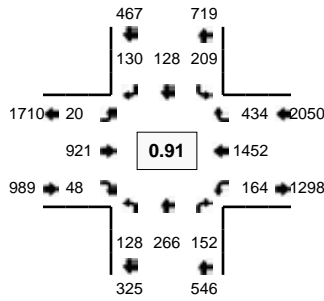

**Peak-Hour: 7:20 AM -- 8:20 AM**  
**Peak 15-Min: 8:00 AM -- 8:15 AM**

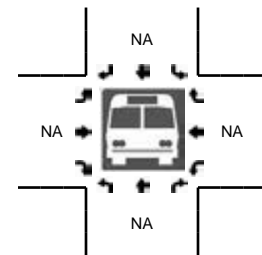
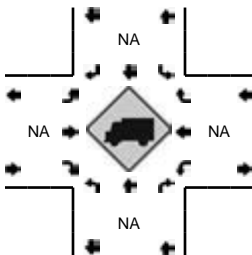
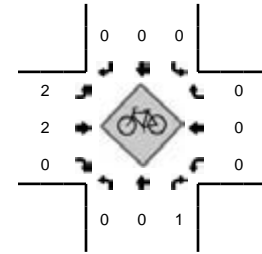
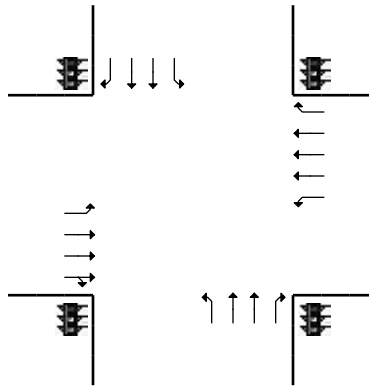
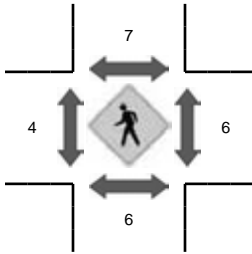
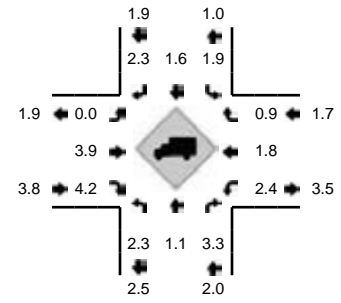

5-Min Count Period Beginning At	Nieman Blvd (Northbound)				Nieman Blvd (Southbound)				Aborn Rd (Eastbound)				Aborn Rd (Westbound)				Total	Hourly Totals
	Left	Thru	Right	U	Left	Thru	Right	U	Left	Thru	Right	U	Left	Thru	Right	U		
7:00 AM	3	12	8	0	4	16	9	0	0	33	1	0	4	92	14	0	196	
7:05 AM	12	28	11	0	5	6	15	0	2	40	3	1	9	85	34	0	251	
7:10 AM	8	15	16	0	5	4	10	0	3	66	6	0	4	118	27	0	282	
7:15 AM	7	25	18	0	12	7	10	0	2	73	2	1	6	92	40	0	295	
7:20 AM	8	18	10	0	15	8	13	0	1	71	1	0	7	102	42	2	298	
7:25 AM	9	22	12	1	16	2	16	0	0	89	5	0	7	106	49	0	334	
7:30 AM	9	15	9	0	18	2	10	0	0	66	5	0	7	107	25	1	274	
7:35 AM	18	26	8	0	18	8	9	0	1	61	2	0	10	120	32	2	315	
7:40 AM	2	20	5	0	13	9	13	0	0	53	3	0	20	127	36	2	303	
7:45 AM	10	21	11	0	16	16	11	0	0	90	5	0	10	138	26	0	354	
7:50 AM	19	21	22	0	29	19	7	0	0	80	7	0	14	113	30	0	361	
7:55 AM	8	22	16	0	17	24	11	0	3	94	8	0	12	99	28	4	346	3609
8:00 AM	8	25	8	0	19	13	9	0	2	110	2	0	14	153	32	1	396	3809
8:05 AM	14	22	18	0	23	10	15	0	4	63	2	0	17	118	40	1	347	3905
8:10 AM	13	36	13	0	16	14	10	0	3	69	3	0	17	120	48	3	365	3988
8:15 AM	9	18	20	0	9	3	6	0	5	75	5	1	13	149	46	0	359	4052
8:20 AM	7	8	8	0	7	1	5	0	2	73	4	0	11	124	21	0	271	4025
8:25 AM	6	19	11	0	12	10	3	0	3	42	5	0	9	115	35	0	270	3961
8:30 AM	4	6	6	0	8	2	9	0	2	64	1	0	7	142	31	1	283	3970
8:35 AM	2	8	7	0	11	8	9	0	1	61	4	0	4	120	25	0	260	3915
8:40 AM	6	19	11	0	20	6	4	0	0	62	2	0	8	107	26	0	271	3883
8:45 AM	3	6	10	0	15	5	5	0	0	103	3	0	5	121	37	1	314	3843
8:50 AM	3	13	4	0	12	7	12	0	0	86	4	0	6	118	30	2	297	3779
8:55 AM	11	19	9	0	18	8	3	1	0	65	1	0	4	120	25	0	284	3717
Peak 15-Min Flowrates	Northbound				Southbound				Eastbound				Westbound				Total	
All Vehicles	140	332	156	0	232	148	136	0	36	968	28	0	192	1564	480	20	4432	
Heavy Trucks	0	4	0		4	4	0		0	20	0		12	20	0		64	
Pedestrians		4				4				0				8			16	
Bicycles	0	0	0		0	0	0		0	0	0		0	0	0		0	
Railroad																		
Stopped Buses																		

Comments: Please conduct vehicular turning movement counts, pedestrian counts, and bicycle counts at this intersection.

LOCATION: Nieman Blvd -- Aborn Rd  
 CITY/STATE: San Jose, CA

QC JOB #: 10653048  
 DATE: Wed, Sep 14 2011

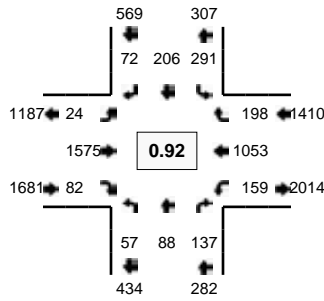

Peak-Hour: 5:00 PM -- 6:00 PM  
 Peak 15-Min: 5:35 PM -- 5:50 PM

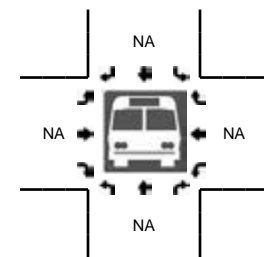
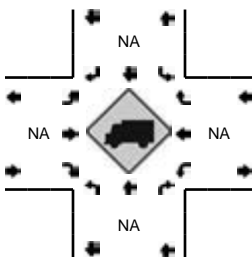
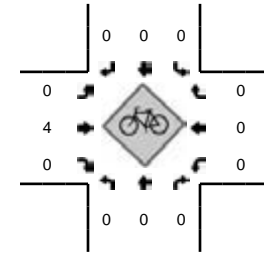
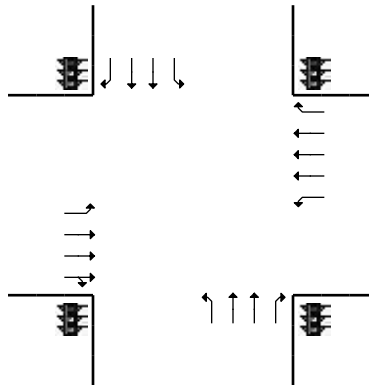
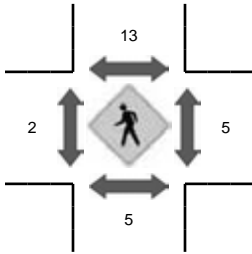
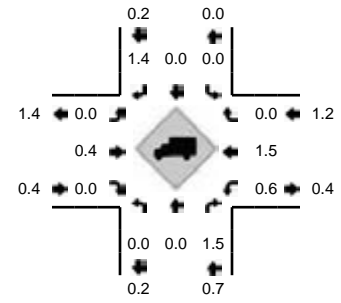

5-Min Count Period Beginning At	Nieman Blvd (Northbound)				Nieman Blvd (Southbound)				Aborn Rd (Eastbound)				Aborn Rd (Westbound)				Total	Hourly Totals
	Left	Thru	Right	U	Left	Thru	Right	U	Left	Thru	Right	U	Left	Thru	Right	U		
4:00 PM	1	8	3	0	17	6	6	0	2	126	3	1	4	79	11	2	269	
4:05 PM	7	14	11	0	9	14	10	0	4	69	6	0	9	89	19	0	261	
4:10 PM	3	5	9	0	20	9	4	1	2	96	4	0	9	67	10	0	239	
4:15 PM	2	6	3	0	14	16	6	0	2	125	9	0	4	81	10	0	278	
4:20 PM	3	5	7	0	17	7	8	0	4	107	5	1	6	96	6	1	273	
4:25 PM	2	9	8	0	12	11	9	0	0	114	12	0	6	74	15	2	274	
4:30 PM	5	6	11	0	20	19	6	0	2	110	3	0	8	70	16	1	277	
4:35 PM	2	12	8	0	14	20	6	0	2	95	9	0	7	79	14	2	270	
4:40 PM	7	8	11	0	15	14	7	0	2	103	3	0	15	92	19	2	298	
4:45 PM	7	7	9	0	25	15	5	0	1	76	3	0	7	67	8	1	231	
4:50 PM	3	13	7	0	24	20	5	1	1	130	5	0	12	81	8	0	310	
4:55 PM	3	7	15	0	20	16	6	0	2	113	5	0	9	90	15	1	302	3282
5:00 PM	5	6	2	0	16	9	7	0	1	107	11	1	8	76	18	2	269	3282
5:05 PM	3	9	12	0	21	17	6	0	2	118	6	0	9	102	18	2	325	3346
5:10 PM	2	7	7	0	22	17	2	0	1	122	5	0	12	88	15	1	301	3408
5:15 PM	6	11	3	0	19	18	2	0	5	115	5	0	12	84	16	2	298	3428
5:20 PM	2	8	9	0	31	24	3	0	1	129	10	2	11	82	15	0	327	3482
5:25 PM	2	6	10	0	31	14	8	0	3	112	6	1	13	83	18	0	307	3515
5:30 PM	5	3	15	0	25	8	5	0	1	145	8	0	8	89	12	0	324	3562
5:35 PM	10	3	13	0	29	25	9	0	2	140	5	0	14	99	20	1	370	3662
5:40 PM	4	9	16	0	22	22	7	0	2	151	7	0	10	88	17	2	357	3721
5:45 PM	4	9	16	0	13	12	7	2	1	151	4	0	19	82	23	0	343	3833
5:50 PM	5	8	15	0	26	13	10	0	0	142	9	0	15	92	13	2	350	3873
5:55 PM	9	9	19	0	34	27	6	0	0	143	6	1	15	88	13	1	371	3942
Peak 15-Min Flowrates	Northbound				Southbound				Eastbound				Westbound				Total	
	Left	Thru	Right	U	Left	Thru	Right	U	Left	Thru	Right	U	Left	Thru	Right	U		
All Vehicles	72	84	180	0	256	236	92	8	20	1768	64	0	172	1076	240	12	4280	
Heavy Trucks	0	0	0		0	0	0		0	8	0		4	16	0		28	
Pedestrians		12				16				4				8			40	
Bicycles	0	0	0		0	0	0		0	2	0		0	0	0		2	
Railroad																		
Stopped Buses																		

Comments: Please conduct vehicular turning movement counts, pedestrian counts, and bicycle counts at this intersection.

LOCATION: Capitol Expy -- Aborn Rd  
 CITY/STATE: San Jose, CA

QC JOB #: 10653050  
 DATE: Wed, Sep 14 2011

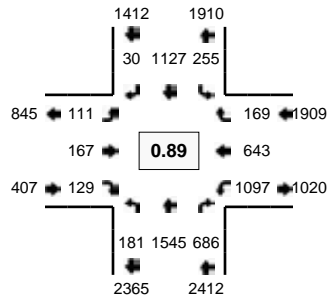

Peak-Hour: 7:25 AM -- 8:25 AM  
 Peak 15-Min: 7:50 AM -- 8:05 AM

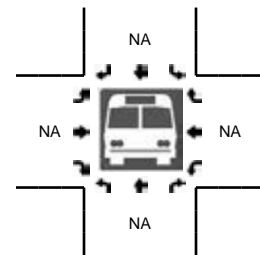
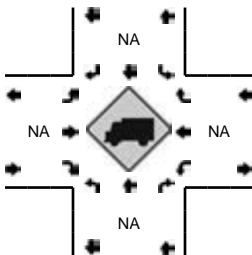
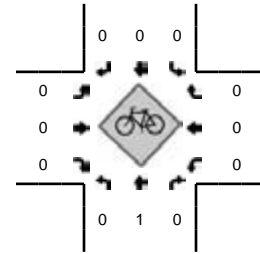
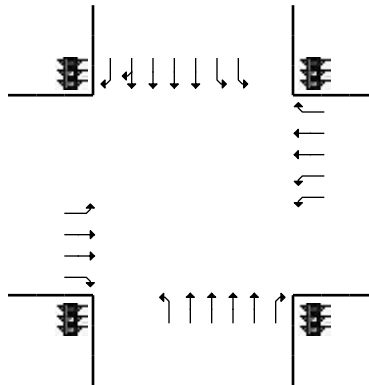
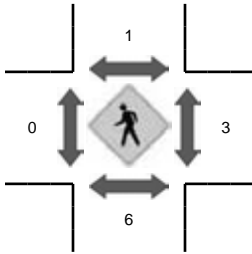
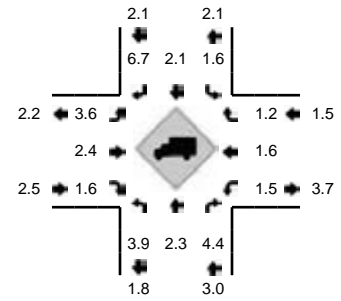

5-Min Count Period Beginning At	Capitol Expy (Northbound)				Capitol Expy (Southbound)				Aborn Rd (Eastbound)				Aborn Rd (Westbound)				Total	Hourly Totals
	Left	Thru	Right	U	Left	Thru	Right	U	Left	Thru	Right	U	Left	Thru	Right	U		
7:00 AM	8	51	22	0	9	48	2	0	8	6	3	0	85	24	8	1	275	
7:05 AM	4	94	46	3	18	71	4	1	2	6	7	0	67	15	11	1	350	
7:10 AM	5	77	44	0	3	74	1	0	5	7	7	0	122	46	24	0	415	
7:15 AM	6	140	63	1	10	116	4	1	7	15	8	0	61	26	9	0	467	
7:20 AM	6	96	41	0	8	70	1	4	5	11	8	0	123	43	13	0	429	
7:25 AM	10	120	74	1	9	56	1	3	13	22	7	0	84	36	10	0	446	
7:30 AM	3	158	52	0	16	111	3	6	5	6	9	0	85	24	15	0	493	
7:35 AM	15	97	41	1	10	51	3	6	7	12	13	0	133	61	6	0	456	
7:40 AM	23	163	64	2	14	130	3	6	5	8	16	1	48	45	13	0	541	
7:45 AM	13	81	46	0	18	81	2	6	12	18	9	1	109	57	19	1	473	
7:50 AM	27	196	78	0	14	107	3	10	10	20	13	1	51	47	10	0	587	
7:55 AM	11	121	72	1	26	125	4	11	0	2	17	0	112	86	13	0	601	5533
8:00 AM	18	141	66	3	14	76	0	6	19	20	6	0	85	56	18	0	528	5786
8:05 AM	6	139	47	1	22	123	3	15	11	6	7	0	87	36	14	0	517	5953
8:10 AM	21	66	54	1	3	59	2	5	12	24	6	0	117	74	19	0	463	6001
8:15 AM	14	162	59	3	9	115	2	8	13	13	10	0	68	40	19	0	535	6069
8:20 AM	7	101	33	0	11	93	4	7	0	16	16	1	117	81	13	0	500	6140
8:25 AM	20	124	48	6	6	79	4	5	6	13	3	0	75	42	9	0	440	6134
8:30 AM	10	104	35	1	14	107	4	4	5	13	7	0	95	46	6	0	451	6092
8:35 AM	14	65	34	1	3	59	1	3	9	18	11	0	92	60	9	0	379	6015
8:40 AM	16	114	64	1	9	119	1	5	2	14	14	0	71	31	8	0	469	5943
8:45 AM	5	39	54	0	6	65	6	2	8	27	13	0	112	41	10	3	391	5861
8:50 AM	13	120	73	3	10	118	7	1	9	21	6	0	59	30	11	2	483	5757
8:55 AM	10	63	44	2	20	88	8	6	3	14	7	0	91	48	4	0	408	5564
Peak 15-Min Flowrates	Northbound				Southbound				Eastbound				Westbound				Total	
	Left	Thru	Right	U	Left	Thru	Right	U	Left	Thru	Right	U	Left	Thru	Right	U		
All Vehicles	224	1832	864	16	216	1232	28	108	116	168	144	4	992	756	164	0	6864	
Heavy Trucks	16	36	28		4	20	0		8	8	4		24	8	8		164	
Pedestrians		4				0				0				0			4	
Bicycles	0	1	0		0	0	0		0	0	0		0	0	0		1	
Railroad																		
Stopped Buses																		

Comments: Please conduct vehicular turning movement counts, pedestrian counts, and bicycle counts at this intersection.



LOCATION: Capitol Expy -- Aborn Rd  
 CITY/STATE: San Jose, CA

QC JOB #: 10653052  
 DATE: Wed, Sep 14 2011

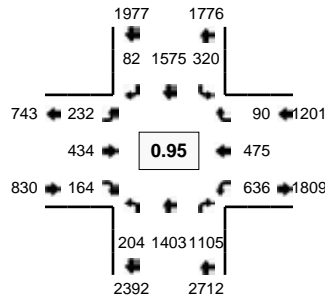

Peak-Hour: 5:00 PM -- 6:00 PM  
 Peak 15-Min: 5:40 PM -- 5:55 PM

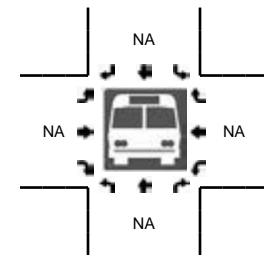
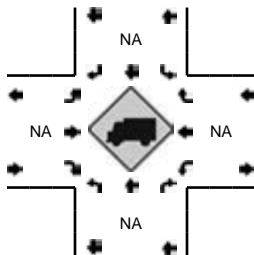
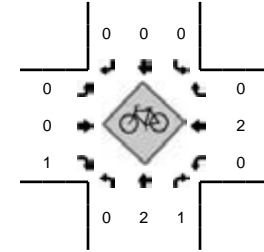
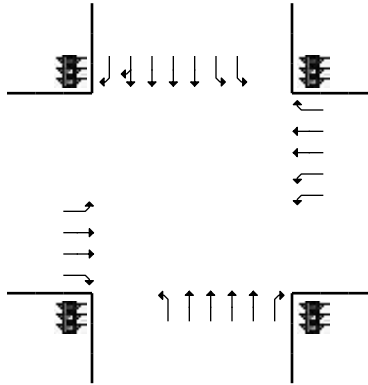
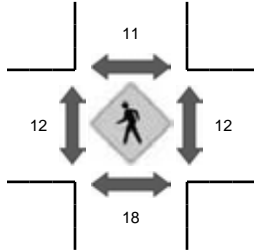
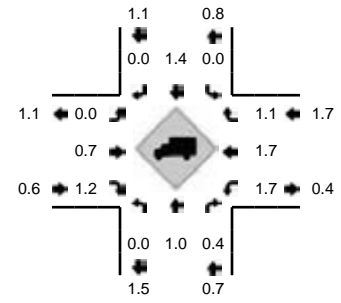

5-Min Count Period Beginning At	Capitol Expy (Northbound)				Capitol Expy (Southbound)				Aborn Rd (Eastbound)				Aborn Rd (Westbound)				Total	Hourly Totals
	Left	Thru	Right	U	Left	Thru	Right	U	Left	Thru	Right	U	Left	Thru	Right	U		
4:00 PM	14	103	74	3	8	110	11	0	20	14	11	1	38	19	11	1	438	
4:05 PM	9	72	50	1	22	116	8	1	8	48	16	0	52	46	4	1	454	
4:10 PM	21	100	80	3	8	64	11	2	14	24	7	3	65	29	10	0	441	
4:15 PM	11	110	75	5	14	149	13	1	10	45	22	0	28	36	10	0	529	
4:20 PM	14	74	76	3	4	76	5	3	25	45	12	3	66	52	7	0	465	
4:25 PM	15	101	79	10	27	130	12	4	11	21	18	2	31	15	2	0	478	
4:30 PM	11	54	63	2	20	113	7	1	20	49	10	1	66	31	6	1	455	
4:35 PM	25	123	96	1	8	113	1	6	25	10	12	1	59	24	11	1	516	
4:40 PM	9	98	52	0	20	153	9	6	13	33	17	2	50	49	7	1	519	
4:45 PM	18	104	111	5	8	82	10	3	21	20	8	1	69	39	9	2	510	
4:50 PM	17	139	86	3	16	163	9	3	8	25	11	2	35	35	2	0	554	
4:55 PM	18	57	70	4	16	82	4	1	20	43	6	1	68	42	7	4	443	5802
5:00 PM	23	129	84	2	27	152	8	5	15	16	12	2	39	22	6	0	542	5906
5:05 PM	5	80	50	0	23	163	9	11	26	48	10	1	57	42	11	0	536	5988
5:10 PM	15	144	105	6	16	89	3	1	20	26	22	0	68	36	5	1	557	6104
5:15 PM	12	118	84	0	25	168	12	4	18	51	16	0	37	48	8	0	601	6176
5:20 PM	23	101	104	2	18	95	2	2	20	37	11	1	67	40	4	1	528	6239
5:25 PM	15	140	90	2	20	157	10	6	14	20	14	1	34	24	11	1	559	6320
5:30 PM	11	80	97	4	29	109	4	5	22	45	12	1	66	54	14	1	554	6419
5:35 PM	12	151	104	4	16	147	8	9	18	18	17	0	51	21	6	1	583	6486
5:40 PM	15	103	83	1	22	151	5	6	20	51	17	0	53	58	3	0	588	6555
5:45 PM	23	120	112	4	10	122	8	3	23	29	10	3	57	41	11	1	577	6622
5:50 PM	12	136	86	1	39	164	10	5	12	47	15	1	30	33	7	3	601	6669
5:55 PM	10	101	106	2	14	58	3	4	14	46	8	0	66	56	4	2	494	6720
Peak 15-Min Flowrates	Northbound				Southbound				Eastbound				Westbound				Total	
All Vehicles	200	1436	1124	24	284	1748	92	56	220	508	168	16	560	528	84	16	7064	
Heavy Trucks	0	8	8		0	24	0		0	0	0		12	8	0		60	
Pedestrians		8				4				8				20			40	
Bicycles	0	0	0		0	0	0		0	0	1		0	2	0		3	
Railroad																		
Stopped Buses																		

Comments: Please conduct vehicular turning movement counts, pedestrian counts, and bicycle counts at this intersection.

# Traffic Data Service

Campbell, CA  
 (408) 377-2988  
 tdsbay@cs.com

File Name : 3AM FINAL  
 Site Code : 00000003  
 Start Date : 10/25/2011  
 Page No : 1

### Groups Printed- Vehicles

Start Time	SILVER CREEK RD Southbound					CAPITOL EXPWY Westbound					SILVER CREEK RD Northbound					CAPITOL EXPWY Eastbound					Int. Total
	Left	Thru	Right	Peds	App. Total	Left	Thru	Right	Peds	App. Total	Left	Thru	Right	Peds	App. Total	Left	Thru	Right	Peds	App. Total	
07:00 AM	6	25	43	0	74	15	426	1	5	447	125	67	25	0	217	125	365	38	0	528	1266
07:15 AM	7	38	59	7	111	17	559	0	5	581	170	87	42	0	299	134	375	42	0	551	1542
07:30 AM	13	45	83	3	144	23	578	2	5	608	136	69	33	0	238	145	492	68	0	705	1695
07:45 AM	8	92	97	1	198	43	564	1	14	622	163	103	45	0	311	149	636	96	0	881	2012
<b>Total</b>	<b>34</b>	<b>200</b>	<b>282</b>	<b>11</b>	<b>527</b>	<b>98</b>	<b>2127</b>	<b>4</b>	<b>29</b>	<b>2258</b>	<b>594</b>	<b>326</b>	<b>145</b>	<b>0</b>	<b>1065</b>	<b>553</b>	<b>1868</b>	<b>244</b>	<b>0</b>	<b>2665</b>	<b>6515</b>
08:00 AM	9	115	88	0	212	37	500	2	15	554	149	173	46	0	368	124	451	71	0	646	1780
08:15 AM	3	70	87	1	161	16	651	4	5	676	187	96	30	0	313	115	446	73	0	634	1784
08:30 AM	11	27	77	0	115	16	561	3	5	585	125	89	27	0	241	149	407	43	0	599	1540
08:45 AM	4	40	77	0	121	10	470	1	2	483	128	57	14	0	199	127	353	58	0	538	1341
<b>Total</b>	<b>27</b>	<b>252</b>	<b>329</b>	<b>1</b>	<b>609</b>	<b>79</b>	<b>2182</b>	<b>10</b>	<b>27</b>	<b>2298</b>	<b>589</b>	<b>415</b>	<b>117</b>	<b>0</b>	<b>1121</b>	<b>515</b>	<b>1657</b>	<b>245</b>	<b>0</b>	<b>2417</b>	<b>6445</b>
<b>Grand Total</b>	<b>61</b>	<b>452</b>	<b>611</b>	<b>12</b>	<b>1136</b>	<b>177</b>	<b>4309</b>	<b>14</b>	<b>56</b>	<b>4556</b>	<b>1183</b>	<b>741</b>	<b>262</b>	<b>0</b>	<b>2186</b>	<b>1068</b>	<b>3525</b>	<b>489</b>	<b>0</b>	<b>5082</b>	<b>12960</b>
Apprch %	5.4	39.8	53.8	1.1		3.9	94.6	0.3	1.2		54.1	33.9	12	0		21	69.4	9.6	0		
Total %	0.5	3.5	4.7	0.1	8.8	1.4	33.2	0.1	0.4	35.2	9.1	5.7	2	0	16.9	8.2	27.2	3.8	0	39.2	

Start Time	SILVER CREEK RD Southbound					CAPITOL EXPWY Westbound					SILVER CREEK RD Northbound					CAPITOL EXPWY Eastbound					Int. Total
	Left	Thru	Right	Peds	App. Total	Left	Thru	Right	Peds	App. Total	Left	Thru	Right	Peds	App. Total	Left	Thru	Right	Peds	App. Total	
Peak Hour Analysis From 07:00 AM to 08:45 AM - Peak 1 of 1																					
Peak Hour for Entire Intersection Begins at 07:30 AM																					
07:30 AM	13	45	83	3	144	23	578	2	5	608	136	69	33	0	238	145	492	68	0	705	1695
07:45 AM	8	92	97	1	198	43	564	1	14	622	163	103	45	0	311	149	636	96	0	881	2012
08:00 AM	9	115	88	0	212	37	500	2	15	554	149	173	46	0	368	124	451	71	0	646	1780
08:15 AM	3	70	87	1	161	16	651	4	5	676	187	96	30	0	313	115	446	73	0	634	1784
<b>Total Volume</b>	<b>33</b>	<b>322</b>	<b>355</b>	<b>5</b>	<b>715</b>	<b>119</b>	<b>2293</b>	<b>9</b>	<b>39</b>	<b>2460</b>	<b>635</b>	<b>441</b>	<b>154</b>	<b>0</b>	<b>1230</b>	<b>533</b>	<b>2025</b>	<b>308</b>	<b>0</b>	<b>2866</b>	<b>7271</b>
% App. Total	4.6	45	49.7	0.7		4.8	93.2	0.4	1.6		51.6	35.9	12.5	0		18.6	70.7	10.7	0		
PHF	.635	.700	.915	.417	.843	.692	.881	.563	.650	.910	.849	.637	.837	.000	.836	.894	.796	.802	.000	.813	.903

# Traffic Data Service

Campbell, CA

(408) 377-2988

tdsbay@cs.com

File Name : 3AM FINAL

Site Code : 00000003

Start Date : 10/25/2011

Page No : 2

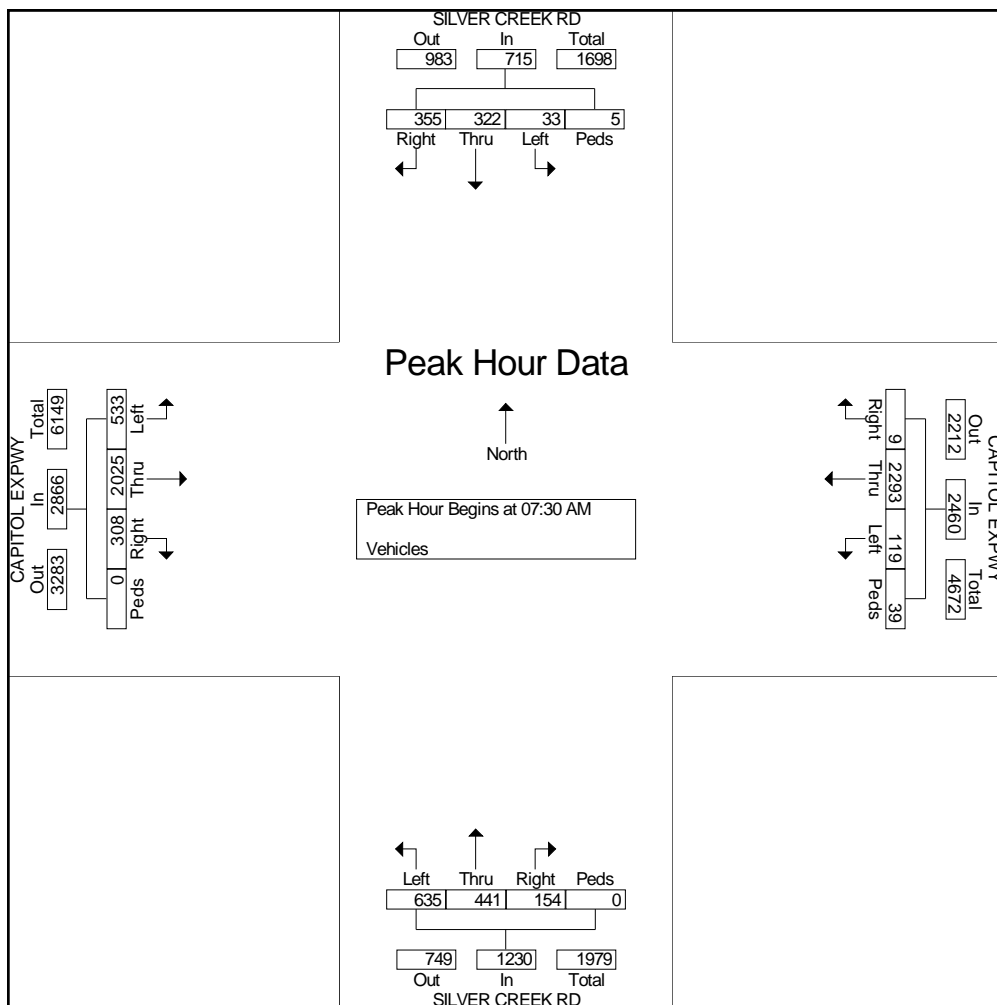

LOCATION: Silver Creek Rd -- Capitol Expy  
 CITY/STATE: San Jose, CA

QC JOB #: 10653056  
 DATE: Wed, Sep 14 2011

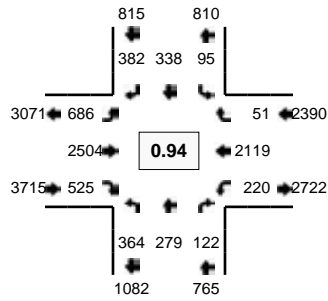

Peak-Hour: 5:00 PM -- 6:00 PM  
 Peak 15-Min: 5:25 PM -- 5:40 PM

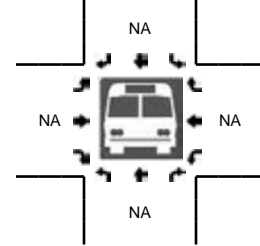
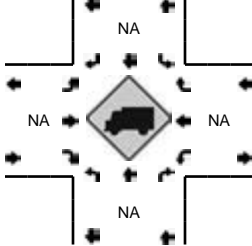
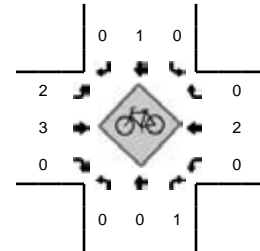
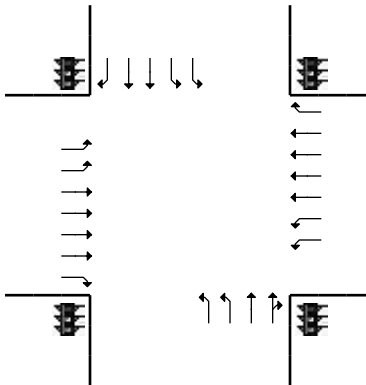
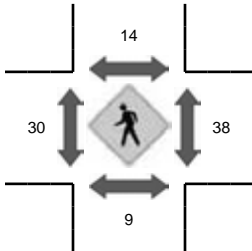
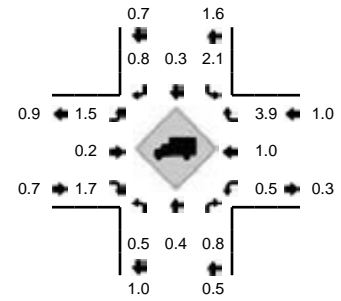

5-Min Count Period Beginning At	Silver Creek Rd (Northbound)				Silver Creek Rd (Southbound)				Capitol Expy (Eastbound)				Capitol Expy (Westbound)				Total	Hourly Totals
	Left	Thru	Right	U	Left	Thru	Right	U	Left	Thru	Right	U	Left	Thru	Right	U		
4:00 PM	24	16	9	0	9	14	23	0	41	156	31	24	11	188	2	0	548	
4:05 PM	26	37	11	0	8	36	31	1	44	144	26	19	14	93	2	0	492	
4:10 PM	39	15	10	0	14	6	26	0	23	178	25	14	14	183	3	0	550	
4:15 PM	22	22	6	0	9	25	44	1	45	188	48	22	18	174	7	2	633	
4:20 PM	44	40	8	0	7	22	38	0	23	119	26	8	5	125	0	1	466	
4:25 PM	17	13	9	0	2	13	28	0	52	194	45	23	15	203	5	1	620	
4:30 PM	28	24	9	0	4	28	30	0	49	125	29	21	18	108	6	0	479	
4:35 PM	45	17	8	0	10	20	27	0	39	218	31	8	13	214	3	0	653	
4:40 PM	21	20	6	0	5	36	34	0	51	175	31	34	23	139	3	1	579	
4:45 PM	37	23	7	0	15	21	36	0	23	187	44	13	12	175	5	0	598	
4:50 PM	18	17	6	0	4	20	34	0	53	242	38	27	20	190	7	0	676	
4:55 PM	40	30	4	0	8	38	29	0	56	129	30	11	30	128	6	0	539	6833
5:00 PM	23	12	8	0	8	20	32	0	39	222	43	22	9	212	4	0	654	6939
5:05 PM	31	29	10	0	5	30	37	0	45	129	26	21	29	106	3	0	501	6948
5:10 PM	41	32	17	0	7	20	28	0	27	233	44	11	17	205	7	0	689	7087
5:15 PM	24	18	10	0	6	33	38	1	50	215	33	25	13	179	0	1	646	7100
5:20 PM	36	20	8	0	8	27	19	0	24	190	46	18	6	175	8	0	585	7219
5:25 PM	21	20	6	0	9	17	29	0	51	248	40	24	24	215	2	0	706	7305
5:30 PM	41	34	3	0	15	45	43	0	30	169	44	20	16	142	4	0	606	7432
5:35 PM	24	18	4	0	6	18	25	1	40	276	51	19	15	227	7	1	732	7511
5:40 PM	32	28	15	0	11	29	41	0	57	186	49	18	25	137	6	0	634	7566
5:45 PM	33	18	16	0	9	34	30	0	25	208	51	6	13	206	5	0	654	7622
5:50 PM	19	19	11	2	2	24	28	0	56	239	49	17	35	179	3	1	684	7630
5:55 PM	37	31	14	0	7	41	32	0	34	189	49	7	15	136	2	0	594	7685
Peak 15-Min Flowrates	Northbound				Southbound				Eastbound				Westbound				Total	
	Left	Thru	Right	U	Left	Thru	Right	U	Left	Thru	Right	U	Left	Thru	Right	U		
All Vehicles	344	288	52	0	120	320	388	4	484	2772	540	252	220	2336	52	4	8176	
Heavy Trucks	0	0	4		4	4	0		0	12	20		4	40	4		92	
Pedestrians		4				20				16				28			68	
Bicycles	0	0	1		0	0	0		0	1	0		0	0	0		2	
Railroad																		
Stopped Buses																		

Comments: Please conduct vehicular turning movement counts, pedestrian counts, and bicycle counts at this intersection.

**APPENDIX B:  
INTERSECTION LEVEL OF SERVICE CALCULATIONS**

## Scenario Report

Scenario: Existing AM

Command: Default Command  
 Volume: Existing AM  
 Geometry: Existing  
 Impact Fee: Default Impact Fee  
 Trip Generation: Existing  
 Trip Distribution: Project  
 Paths: Project  
 Routes: Default Route  
 Configuration: Default Configuration

Impact Analysis Report  
Level Of Service

Intersection	Base		Future		Change in
	Del/	V/	Del/	V/	
	LOS	Veh C	LOS	Veh C	
# 1 U.S. 101 SB Off-ramp/Yerba Bue	C	29.7 0.718	C	29.7 0.718	+ 0.000 D/V
# 2 U.S. 101 NB Off-ramp/Yerba Bue	B	15.2 0.433	B	15.2 0.433	+ 0.000 D/V
# 3 Silver Creek Road/Yerba Buena	B-	18.3 0.521	B-	18.3 0.521	+ 0.000 D/V
# 4 Nieman Boulevard/Silver Creek	C	27.5 0.605	C	27.5 0.605	+ 0.000 D/V
# 5 Byington Drive/Yerba Buena Ave	A	9.6 0.421	A	9.6 0.421	+ 0.000 D/V
# 6 San Felipe Road/Yerba Buena Ro	D+	38.1 0.736	D+	38.1 0.736	+ 0.000 D/V
# 7 Paseo de Arboles/San Felipe Ro	B	15.1 0.402	B	15.1 0.402	+ 0.000 D/V
# 8 Delta Road/San Felipe Road	B-	19.6 0.461	B-	19.6 0.461	+ 0.000 D/V
# 9 Fowler Road/San Felipe Road	B	15.3 0.359	B	15.3 0.359	+ 0.000 D/V
# 10 San Felipe Road/Yerba Buena Av	C+	20.8 0.562	C+	20.8 0.562	+ 0.000 D/V
# 11 Aborn Road/White Road/San Feli	D	48.2 0.742	D	48.2 0.742	+ 0.000 D/V
# 12 Aborn Road/Nieman Boulevard	D	39.1 0.472	D	39.1 0.472	+ 0.000 D/V
# 13 Capitol Expressway/Aborn Road	D-	54.6 0.895	D-	54.6 0.895	+ 0.000 D/V
# 14 Capitol Expressway/Silver Cree	D-	54.5 0.875	D-	54.5 0.875	+ 0.000 D/V

Level of Service Computation Report
2000 HCM Operations Method (Base Volume Alternative)

Intersection #1 U.S. 101 SB Off-ramp/Yerba Buena Road

Cycle (sec): 100 Critical Vol./Cap.(X): 0.718
Loss Time (sec): 0 Average Delay (sec/veh): 29.7
Optimal Cycle: 81 Level of Service: C

Table with columns for Street Name, Approach, Movement, Control, Rights, Min. Green, Y+R, Lanes. Rows for U.S. 101 SB Off-ramp and Yerba Buena Road.

Table for Volume Module showing Base Vol, Growth Adj, Initial Bse, User Adj, PHF Adj, PHF Volume, Reduct Vol, Reduced Vol, PCE Adj, MLF Adj, Final Volume.

Table for Saturation Flow Module showing Sat/Lane, Adjustment, Lanes, Final Sat.

Table for Capacity Analysis Module showing Vol/Sat, Crit Moves, Green Time, Volume/Cap, Uniform Del, IncremntDel, InitQueuDel, Delay Adj, Delay/Veh, User DelAdj, AdjDel/Veh, LOS by Move, HCM2kAvgQ.

Note: Queue reported is the number of cars per lane.

Level of Service Computation Report
2000 HCM Operations Method (Base Volume Alternative)

Intersection #2 U.S. 101 NB Off-ramp/Yerba Buena Road

Cycle (sec): 100 Critical Vol./Cap.(X): 0.433
Loss Time (sec): 0 Average Delay (sec/veh): 15.2
Optimal Cycle: 40 Level of Service: B

Table with columns for Street Name, Approach, Movement, Control, Rights, Min. Green, Y+R, Lanes. Rows for U.S. 101 NB Off-ramp and Yerba Buena Road.

Table for Volume Module showing Base Vol, Growth Adj, Initial Bse, User Adj, PHF Adj, PHF Volume, Reduct Vol, Reduced Vol, PCE Adj, MLF Adj, Final Volume.

Table for Saturation Flow Module showing Sat/Lane, Adjustment, Lanes, Final Sat.

Table for Capacity Analysis Module showing Vol/Sat, Crit Moves, Green Time, Volume/Cap, Uniform Del, IncremntDel, InitQueuDel, Delay Adj, Delay/Veh, User DelAdj, AdjDel/Veh, LOS by Move, HCM2kAvgQ.

Note: Queue reported is the number of cars per lane.

Level of Service Computation Report
2000 HCM Operations Method (Base Volume Alternative)

Intersection #3 Silver Creek Road/Yerba Buena Road

Cycle (sec): 100 Critical Vol./Cap.(X): 0.521
Loss Time (sec): 0 Average Delay (sec/veh): 18.3
Optimal Cycle: 48 Level of Service: B-

Table with columns for Street Name, Approach, Movement, Control, Rights, Min. Green, Y+R, Lanes for Silver Creek Road and Yerba Buena Road.

Table with columns for Volume Module: Base Vol, Growth Adj, Initial Bse, User Adj, PHF Adj, PHF Volume, Reduct Vol, Reduced Vol, PCE Adj, MLF Adj, Final Volume.

Table with columns for Saturation Flow Module: Sat/Lane, Adjustment, Lanes, Final Sat.

Table with columns for Capacity Analysis Module: Vol/Sat, Crit Moves, Green Time, Volume/Cap, Uniform Del, IncremntDel, InitQueueDel, Delay Adj, Delay/Veh, User DelAdj, AdjDel/Veh, LOS by Move, HCM2kAvgQ.

Note: Queue reported is the number of cars per lane.

Level of Service Computation Report
2000 HCM Operations Method (Base Volume Alternative)

Intersection #4 Nieman Boulevard/Silver Creek Valley Road/Yerba Buena Road

Cycle (sec): 100 Critical Vol./Cap.(X): 0.605
Loss Time (sec): 0 Average Delay (sec/veh): 27.5
Optimal Cycle: 58 Level of Service: C

Table with columns for Street Name, Approach, Movement, Control, Rights, Min. Green, Y+R, Lanes for Nieman Boulevard and Yerba Buena Road.

Table with columns for Volume Module: Base Vol, Growth Adj, Initial Bse, User Adj, PHF Adj, PHF Volume, Reduct Vol, Reduced Vol, PCE Adj, MLF Adj, Final Volume.

Table with columns for Saturation Flow Module: Sat/Lane, Adjustment, Lanes, Final Sat.

Table with columns for Capacity Analysis Module: Vol/Sat, Crit Moves, Green Time, Volume/Cap, Uniform Del, IncremntDel, InitQueueDel, Delay Adj, Delay/Veh, User DelAdj, AdjDel/Veh, LOS by Move, HCM2kAvgQ.

Note: Queue reported is the number of cars per lane.



Level of Service Computation Report
2000 HCM Operations Method (Base Volume Alternative)

Intersection #5 Byington Drive/Yerba Buena Avenue/Yerba Buena Road

Cycle (sec): 100 Critical Vol./Cap.(X): 0.421
Loss Time (sec): 0 Average Delay (sec/veh): 9.6
Optimal Cycle: 39 Level of Service: A

Table with columns for Street Name, Approach, Movement, Control, Rights, Min. Green, Y+R, Lanes for Byington Drive and Yerba Buena Avenue.

Table with columns for Volume Module: Base Vol, Growth Adj, Initial Bse, User Adj, PHF Adj, PHF Volume, Reduct Vol, Reduced Vol, PCE Adj, MLF Adj, Final Volume.

Table with columns for Saturation Flow Module: Sat/Lane, Adjustment, Lanes, Final Sat.

Table with columns for Capacity Analysis Module: Vol/Sat, Crit Moves, Green Time, Volume/Cap, Uniform Del, IncremntDel, InitQueueDel, Delay Adj, Delay/Veh, User DelAdj, AdjDel/Veh, LOS by Move, HCM2kAvgQ.

Note: Queue reported is the number of cars per lane.

Level of Service Computation Report
2000 HCM Operations Method (Base Volume Alternative)

Intersection #6 San Felipe Road/Yerba Buena Road

Cycle (sec): 120 Critical Vol./Cap.(X): 0.736
Loss Time (sec): 0 Average Delay (sec/veh): 38.1
Optimal Cycle: 86 Level of Service: D+

Table with columns for Street Name, Approach, Movement, Control, Rights, Min. Green, Y+R, Lanes for San Felipe Road and Yerba Buena Road.

Table with columns for Volume Module: Base Vol, Growth Adj, Initial Bse, User Adj, PHF Adj, PHF Volume, Reduct Vol, Reduced Vol, PCE Adj, MLF Adj, Final Volume.

Table with columns for Saturation Flow Module: Sat/Lane, Adjustment, Lanes, Final Sat.

Table with columns for Capacity Analysis Module: Vol/Sat, Crit Moves, Green Time, Volume/Cap, Uniform Del, IncremntDel, InitQueueDel, Delay Adj, Delay/Veh, User DelAdj, AdjDel/Veh, LOS by Move, HCM2kAvgQ.

Note: Queue reported is the number of cars per lane.

Level of Service Computation Report
2000 HCM Operations Method (Base Volume Alternative)

Intersection #7 Paseo de Arboles/San Felipe Road

Cycle (sec): 100 Critical Vol./Cap.(X): 0.402
Loss Time (sec): 0 Average Delay (sec/veh): 15.1
Optimal Cycle: 38 Level of Service: B

Table with columns for Street Name, Approach, Movement, Control, Rights, Min. Green, Y+R, Lanes. Rows include San Felipe Road and Paseo de Arboles with North and South Bound movements.

Table for Volume Module showing Base Vol, Growth Adj, Initial Bse, User Adj, PHF Adj, PHF Volume, Reduct Vol, Reduced Vol, PCE Adj, MLF Adj, Final Volume.

Table for Saturation Flow Module showing Sat/Lane, Adjustment, Lanes, Final Sat.

Table for Capacity Analysis Module showing Vol/Sat, Crit Moves, Green Time, Volume/Cap, Uniform Del, IncremntDel, InitQueuDel, Delay Adj, Delay/Veh, User DelAdj, AdjDel/Veh, LOS by Move, HCM2kAvgQ.

Note: Queue reported is the number of cars per lane.

Level of Service Computation Report
2000 HCM Operations Method (Base Volume Alternative)

Intersection #8 Delta Road/San Felipe Road

Cycle (sec): 100 Critical Vol./Cap.(X): 0.461
Loss Time (sec): 0 Average Delay (sec/veh): 19.6
Optimal Cycle: 42 Level of Service: B-

Table with columns for Street Name, Approach, Movement, Control, Rights, Min. Green, Y+R, Lanes. Rows include San Felipe Road and Delta Road with North and South Bound movements.

Table for Volume Module showing Base Vol, Growth Adj, Initial Bse, User Adj, PHF Adj, PHF Volume, Reduct Vol, Reduced Vol, PCE Adj, MLF Adj, Final Volume.

Table for Saturation Flow Module showing Sat/Lane, Adjustment, Lanes, Final Sat.

Table for Capacity Analysis Module showing Vol/Sat, Crit Moves, Green Time, Volume/Cap, Uniform Del, IncremntDel, InitQueuDel, Delay Adj, Delay/Veh, User DelAdj, AdjDel/Veh, LOS by Move, HCM2kAvgQ.

Note: Queue reported is the number of cars per lane.

Level of Service Computation Report
2000 HCM Operations Method (Base Volume Alternative)

Intersection #9 Fowler Road/San Felipe Road

Cycle (sec): 100 Critical Vol./Cap.(X): 0.359
Loss Time (sec): 0 Average Delay (sec/veh): 15.3
Optimal Cycle: 36 Level of Service: B

Table with columns for Street Name (San Felipe Road, Fowler Road), Approach (North Bound, South Bound, East Bound, West Bound), Movement (L, T, R), Control (Protected, Include), Rights, Min. Green, Y+R, and Lanes.

Table for Volume Module showing Base Vol, Growth Adj, Initial Bse, User Adj, PHF Adj, PHF Volume, Reduct Vol, Reduced Vol, PCE Adj, MLF Adj, and Final Volume for various movements.

Table for Saturation Flow Module showing Sat/Lane, Adjustment, Lanes, and Final Sat. for various movements.

Table for Capacity Analysis Module showing Vol/Sat, Crit Moves, Green Time, Volume/Cap, Uniform Del, IncremntDel, InitQueueDel, Delay Adj, Delay/Veh, User DelAdj, AdjDel/Veh, LOS by Move, and HCM2kAvgQ.

Note: Queue reported is the number of cars per lane.

Level of Service Computation Report
2000 HCM Operations Method (Base Volume Alternative)

Intersection #10 San Felipe Road/Yerba Buena Avenue

Cycle (sec): 100 Critical Vol./Cap.(X): 0.562
Loss Time (sec): 0 Average Delay (sec/veh): 20.8
Optimal Cycle: 52 Level of Service: C+

Table with columns for Street Name (San Felipe Road, Yerba Buena Avenue), Approach (North Bound, South Bound, East Bound, West Bound), Movement (L, T, R), Control (Protected, Include), Rights, Min. Green, Y+R, and Lanes.

Table for Volume Module showing Base Vol, Growth Adj, Initial Bse, User Adj, PHF Adj, PHF Volume, Reduct Vol, Reduced Vol, PCE Adj, MLF Adj, and Final Volume for various movements.

Table for Saturation Flow Module showing Sat/Lane, Adjustment, Lanes, and Final Sat. for various movements.

Table for Capacity Analysis Module showing Vol/Sat, Crit Moves, Green Time, Volume/Cap, Uniform Del, IncremntDel, InitQueueDel, Delay Adj, Delay/Veh, User DelAdj, AdjDel/Veh, LOS by Move, and HCM2kAvgQ.

Note: Queue reported is the number of cars per lane.

## Level of Service Computation Report

2000 HCM Operations Method (Base Volume Alternative)

\*\*\*\*\*  
Intersection #11 Aborn Road/White Road/San Felipe Road  
\*\*\*\*\*

Cycle (sec):	155	Critical Vol./Cap.(X):	0.742
Loss Time (sec):	0	Average Delay (sec/veh):	48.2
Optimal Cycle:	88	Level of Service:	D

Street Name:	San Felipe Road			Aborn Road		
Approach:	North Bound		South Bound	East Bound		West Bound
Movement:	L	T	R	L	T	R
Control:	Protected		Protected	Protected		Protected
Rights:	Include		Include	Include		Include
Min. Green:	7	10	10	7	10	10
Y+R:	4.0	4.0	4.0	4.0	4.0	4.0
Lanes:	2	0	2	0	2	0

Volume Module:	San Felipe Road			Aborn Road		
Base Vol:	410	501	88	80	503	518
Growth Adj:	1.00	1.00	1.00	1.00	1.00	1.00
Initial Bse:	410	501	88	80	503	518
User Adj:	1.00	1.00	1.00	1.00	1.00	1.00
PHF Adj:	1.00	1.00	1.00	1.00	1.00	1.00
PHF Volume:	410	501	88	80	503	518
Reduct Vol:	0	0	0	0	0	0
Reduced Vol:	410	501	88	80	503	518
PCE Adj:	1.00	1.00	1.00	1.00	1.00	1.00
MLF Adj:	1.00	1.00	1.00	1.00	1.00	1.00
FinalVolume:	410	501	88	80	503	518

Saturation Flow Module:	San Felipe Road			Aborn Road		
Sat/Lane:	1900	1900	1900	1900	1900	1900
Adjustment:	0.83	1.00	0.92	0.83	1.00	0.92
Lanes:	2.00	2.00	1.00	2.00	2.00	1.00
Final Sat.:	3150	3800	1750	3150	5700	1750

Capacity Analysis Module:	San Felipe Road			Aborn Road		
Vol/Sat:	0.13	0.13	0.05	0.03	0.13	0.30
Crit Moves:	****	****	****	****	****	****
Green Time:	27.2	66.3	66.3	22.7	61.8	61.8
Volume/Cap:	0.74	0.31	0.12	0.17	0.33	0.74
Uniform Del:	60.6	29.2	26.7	57.9	32.3	39.8
IncrcmntDel:	5.4	0.1	0.1	0.2	0.1	4.3
InitQueueDel:	0.0	0.0	0.0	0.0	0.0	0.0
Delay Adj:	1.00	1.00	1.00	1.00	1.00	1.00
Delay/Veh:	66.0	29.3	26.8	58.1	32.4	44.1
User DelAdj:	1.00	1.00	1.00	1.00	1.00	1.00
AdjDel/Veh:	66.0	29.3	26.8	58.1	32.4	44.1
LOS by Move:	E	C	C	E+	C-	D
HCM2kAvgQ:	11	7	3	2	8	23

Note: Queue reported is the number of cars per lane.

## Level of Service Computation Report

2000 HCM Operations Method (Base Volume Alternative)

\*\*\*\*\*  
Intersection #12 Aborn Road/Nieman Boulevard  
\*\*\*\*\*

Cycle (sec):	170	Critical Vol./Cap.(X):	0.472
Loss Time (sec):	0	Average Delay (sec/veh):	39.1
Optimal Cycle:	43	Level of Service:	D

Street Name:	Nieman Boulevard			Aborn Road		
Approach:	North Bound		South Bound	East Bound		West Bound
Movement:	L	T	R	L	T	R
Control:	Protected		Protected	Protected		Protected
Rights:	Include		Include	Include		Include
Min. Green:	7	10	10	7	10	10
Y+R:	4.0	4.0	4.0	4.0	4.0	4.0
Lanes:	1	0	2	0	1	1

Volume Module:	Nieman Boulevard			Aborn Road		
Base Vol:	128	266	152	209	128	130
Growth Adj:	1.00	1.00	1.00	1.00	1.00	1.00
Initial Bse:	128	266	152	209	128	130
User Adj:	1.00	1.00	1.00	1.00	1.00	1.00
PHF Adj:	1.00	1.00	1.00	1.00	1.00	1.00
PHF Volume:	128	266	152	209	128	130
Reduct Vol:	0	0	0	0	0	0
Reduced Vol:	128	266	152	209	128	130
PCE Adj:	1.00	1.00	1.00	1.00	1.00	1.00
MLF Adj:	1.00	1.00	1.00	1.00	1.00	1.00
FinalVolume:	128	266	152	209	128	130

Saturation Flow Module:	Nieman Boulevard			Aborn Road		
Sat/Lane:	1900	1900	1900	1900	1900	1900
Adjustment:	0.92	1.00	0.92	0.92	1.00	0.92
Lanes:	1.00	2.00	1.00	1.00	2.00	1.00
Final Sat.:	1750	3800	1750	1750	3800	1750

Capacity Analysis Module:	Nieman Boulevard			Aborn Road		
Vol/Sat:	0.07	0.07	0.09	0.12	0.03	0.07
Crit Moves:	****	****	****	****	****	****
Green Time:	36.2	30.7	30.7	42.2	36.8	36.8
Volume/Cap:	0.34	0.39	0.48	0.48	0.16	0.34
Uniform Del:	56.8	61.4	62.5	54.5	54.0	56.4
IncrcmntDel:	0.6	0.4	1.2	0.8	0.1	0.5
InitQueueDel:	0.0	0.0	0.0	0.0	0.0	0.0
Delay Adj:	1.00	1.00	1.00	1.00	1.00	1.00
Delay/Veh:	57.4	61.7	63.6	55.4	54.1	57.0
User DelAdj:	1.00	1.00	1.00	1.00	1.00	1.00
AdjDel/Veh:	57.4	61.7	63.6	55.4	54.1	57.0
LOS by Move:	E+	E	E	E+	D-	E+
HCM2kAvgQ:	6	6	8	10	3	6

Note: Queue reported is the number of cars per lane.

Level of Service Computation Report
2000 HCM Operations Method (Base Volume Alternative)

Intersection #13 Capitol Expressway/Aborn Road

Cycle (sec): 190 Critical Vol./Cap.(X): 0.895
Loss Time (sec): 0 Average Delay (sec/veh): 54.6
Optimal Cycle: 180 Level of Service: D-

Table with columns for Street Name, Approach, Movement, Control, Rights, Min. Green, Y+R, Lanes. Rows include Capitol Expresswa and Aborn Road with North and South Bound movements.

Table with columns for Volume Module: Base Vol, Growth Adj, Initial Bse, User Adj, PHF Adj, PHF Volume, Reduct Vol, Reduced Vol, PCE Adj, MLF Adj, Final Volume.

Table with columns for Saturation Flow Module: Sat/Lane, Adjustment, Lanes, Final Sat.

Table with columns for Capacity Analysis Module: Vol/Sat, Crit Moves, Green Time, Volume/Cap, Uniform Del, IncremntDel, InitQueuDel, Delay Adj, Delay/Veh, User DelAdj, AdjDel/Veh, LOS by Move, HCM2kAvgQ.

Note: Queue reported is the number of cars per lane.

Level of Service Computation Report
2000 HCM Operations Method (Base Volume Alternative)

Intersection #14 Capitol Expressway/Silver Creek Road

Cycle (sec): 190 Critical Vol./Cap.(X): 0.875
Loss Time (sec): 0 Average Delay (sec/veh): 54.5
Optimal Cycle: 180 Level of Service: D-

Table with columns for Street Name, Approach, Movement, Control, Rights, Min. Green, Y+R, Lanes. Rows include Capitol Expresswa and Silver Creek Road with North and South Bound movements.

Table with columns for Volume Module: Base Vol, Growth Adj, Initial Bse, User Adj, PHF Adj, PHF Volume, Reduct Vol, Reduced Vol, PCE Adj, MLF Adj, Final Volume.

Table with columns for Saturation Flow Module: Sat/Lane, Adjustment, Lanes, Final Sat.

Table with columns for Capacity Analysis Module: Vol/Sat, Crit Moves, Green Time, Volume/Cap, Uniform Del, IncremntDel, InitQueuDel, Delay Adj, Delay/Veh, User DelAdj, AdjDel/Veh, LOS by Move, HCM2kAvgQ.

Note: Queue reported is the number of cars per lane.

## Scenario Report

Scenario: Existing PM

Command: Default Command  
 Volume: Existing PM  
 Geometry: Existing  
 Impact Fee: Default Impact Fee  
 Trip Generation: Existing  
 Trip Distribution: Project  
 Paths: Project  
 Routes: Default Route  
 Configuration: Default Configuration

Impact Analysis Report  
Level Of Service

Intersection	Base		Future		Change in
	Del/	V/	Del/	V/	
	LOS	Veh C	LOS	Veh C	
# 1 U.S. 101 SB Off-ramp/Yerba Bue	C	30.6 0.729	C	30.6 0.729	+ 0.000 D/V
# 2 U.S. 101 NB Off-ramp/Yerba Bue	B	16.6 0.419	B	16.6 0.419	+ 0.000 D/V
# 3 Silver Creek Road/Yerba Buena	B-	18.4 0.417	B-	18.4 0.417	+ 0.000 D/V
# 4 Nieman Boulevard/Silver Creek	C	27.1 0.580	C	27.1 0.580	+ 0.000 D/V
# 5 Byington Drive/Yerba Buena Ave	A	8.1 0.422	A	8.1 0.422	+ 0.000 D/V
# 6 San Felipe Road/Yerba Buena Ro	D+	37.8 0.692	D+	37.8 0.692	+ 0.000 D/V
# 7 Paseo de Arboles/San Felipe Ro	B	16.9 0.414	B	16.9 0.414	+ 0.000 D/V
# 8 Delta Road/San Felipe Road	B	16.9 0.359	B	16.9 0.359	+ 0.000 D/V
# 9 Fowler Road/San Felipe Road	B+	10.5 0.329	B+	10.5 0.329	+ 0.000 D/V
# 10 San Felipe Road/Yerba Buena Av	B-	19.6 0.656	B-	19.6 0.656	+ 0.000 D/V
# 11 Aborn Road/White Road/San Feli	D	49.2 0.702	D	49.2 0.702	+ 0.000 D/V
# 12 Aborn Road/Nieman Boulevard	D	39.2 0.631	D	39.2 0.631	+ 0.000 D/V
# 13 Capitol Expressway/Aborn Road	E	67.2 1.049	E	67.2 1.049	+ 0.000 D/V
# 14 Capitol Expressway/Silver Cree	D-	52.0 0.830	D-	52.0 0.830	+ 0.000 D/V

Level Of Service Computation Report  
2000 HCM Operations Method (Base Volume Alternative)

\*\*\*\*\*  
Intersection #1 U.S. 101 SB Off-ramp/Yerba Buena Road  
\*\*\*\*\*

Cycle (sec):	100	Critical Vol./Cap.(X):	0.729
Loss Time (sec):	0	Average Delay (sec/veh):	30.6
Optimal Cycle:	84	Level Of Service:	C

Street Name:	U.S. 101 SB Off-ramp			Yerba Buena Road															
Approach:	North Bound		South Bound		East Bound		West Bound												
Movement:	L	T	R	L	T	R	L	T	R	L	T	R							
Control:	Protected			Protected			Protected			Protected									
Rights:	Include			Include			Include			Include									
Min. Green:	7	10	10	7	10	10	7	10	10	7	10	10							
Y+R:	4.0	4.0	4.0	4.0	4.0	4.0	4.0	4.0	4.0	4.0	4.0	4.0							
Lanes:	0	0	0	0	1	0	0	1	0	0	0	2	0	1	1	0	2	0	0

Volume Module:												
Base Vol:	0	0	0	666	38	120	0	649	87	311	429	0
Growth Adj:	1.00	1.00	1.00	1.00	1.00	1.00	1.00	1.00	1.00	1.00	1.00	1.00
Initial Bse:	0	0	0	666	38	120	0	649	87	311	429	0
User Adj:	1.00	1.00	1.00	1.00	1.00	1.00	1.00	1.00	1.00	1.00	1.00	1.00
PHF Adj:	1.00	1.00	1.00	1.00	1.00	1.00	1.00	1.00	1.00	1.00	1.00	1.00
PHF Volume:	0	0	0	666	38	120	0	649	87	311	429	0
Reduct Vol:	0	0	0	0	0	0	0	0	0	0	0	0
Reduced Vol:	0	0	0	666	38	120	0	649	87	311	429	0
PCE Adj:	1.00	1.00	1.00	1.00	1.00	1.00	1.00	1.00	1.00	1.00	1.00	1.00
MLF Adj:	1.00	1.00	1.00	1.00	1.00	1.00	1.00	1.00	1.00	1.00	1.00	1.00
Final Volume:	0	0	0	666	38	120	0	649	87	311	429	0

Saturation Flow Module:												
Sat/Lane:	1900	1900	1900	1900	1900	1900	1900	1900	1900	1900	1900	1900
Adjustment:	0.92	1.00	0.92	0.92	0.95	0.95	0.92	1.00	0.92	0.92	1.00	0.92
Lanes:	0.00	0.00	0.00	1.00	0.24	0.76	0.00	2.00	1.00	1.00	2.00	0.00
Final Sat.:	0	0	0	1750	433	1367	0	3800	1750	1750	3800	0

Capacity Analysis Module:												
Vol/Sat:	0.00	0.00	0.00	0.38	0.09	0.09	0.00	0.17	0.05	0.18	0.11	0.00
Crit Moves:	****			****			****			****		
Green Time:	0.0	0.0	0.0	52.2	36.6	36.6	0.0	23.4	23.4	24.4	29.5	0.0
Volume/Cap:	0.00	0.00	0.00	0.73	0.24	0.24	0.00	0.73	0.21	0.73	0.38	0.00
Uniform Del:	0.0	0.0	0.0	18.4	22.0	22.0	0.0	35.4	30.9	34.8	28.0	0.0
IncremntDel:	0.0	0.0	0.0	3.0	0.2	0.2	0.0	3.1	0.3	6.3	0.2	0.0
InitQueueDel:	0.0	0.0	0.0	0.0	0.0	0.0	0.0	0.0	0.0	0.0	0.0	0.0
Delay Adj:	0.00	0.00	0.00	1.00	1.00	1.00	0.00	1.00	1.00	1.00	1.00	0.00
Delay/Veh:	0.0	0.0	0.0	21.4	22.2	22.2	0.0	38.4	31.1	41.0	28.2	0.0
User DelAdj:	1.00	1.00	1.00	1.00	1.00	1.00	1.00	1.00	1.00	1.00	1.00	1.00
AdjDel/Veh:	0.0	0.0	0.0	21.4	22.2	22.2	0.0	38.4	31.1	41.0	28.2	0.0
LOS by Move:	A	A	A	C+	C+	C+	A	D+	C	D	C	A
HCM2kAvgQ:	0	0	0	18	4	4	0	11	2	10	5	0

Note: Queue reported is the number of cars per lane.

Level Of Service Computation Report  
2000 HCM Operations Method (Base Volume Alternative)

\*\*\*\*\*  
Intersection #2 U.S. 101 NB Off-ramp/Yerba Buena Road  
\*\*\*\*\*

Cycle (sec):	100	Critical Vol./Cap.(X):	0.419
Loss Time (sec):	0	Average Delay (sec/veh):	16.6
Optimal Cycle:	39	Level Of Service:	B

Street Name:	U.S. 101 NB Off-ramp			Yerba Buena Road																
Approach:	North Bound		South Bound		East Bound		West Bound													
Movement:	L	T	R	L	T	R	L	T	R	L	T	R								
Control:	Protected			Protected			Protected			Protected										
Rights:	Include			Include			Include			Include										
Min. Green:	7	10	10	7	10	10	7	10	10	7	10	10								
Y+R:	4.0	4.0	4.0	4.0	4.0	4.0	4.0	4.0	4.0	4.0	4.0	4.0								
Lanes:	0	0	1	0	1	0	1	0	0	1	0	1	1	0	0	1	0	2	0	1

Volume Module:												
Base Vol:	0	2	1	279	0	81	151	1180	0	1	632	513
Growth Adj:	1.00	1.00	1.00	1.00	1.00	1.00	1.00	1.00	1.00	1.00	1.00	1.00
Initial Bse:	0	2	1	279	0	81	151	1180	0	1	632	513
User Adj:	1.00	1.00	1.00	1.00	1.00	1.00	1.00	1.00	1.00	1.00	1.00	1.00
PHF Adj:	1.00	1.00	1.00	1.00	1.00	1.00	1.00	1.00	1.00	1.00	1.00	1.00
PHF Volume:	0	2	1	279	0	81	151	1180	0	1	632	513
Reduct Vol:	0	0	0	0	0	0	0	0	0	0	0	0
Reduced Vol:	0	2	1	279	0	81	151	1180	0	1	632	513
PCE Adj:	1.00	1.00	1.00	1.00	1.00	1.00	1.00	1.00	1.00	1.00	1.00	1.00
MLF Adj:	1.00	1.00	1.00	1.00	1.00	1.00	1.00	1.00	1.00	1.00	1.00	1.00
Final Volume:	0	2	1	279	0	81	151	1180	0	1	632	513

Saturation Flow Module:												
Sat/Lane:	1900	1900	1900	1900	1900	1900	1900	1900	1900	1900	1900	1900
Adjustment:	0.92	0.95	0.95	0.92	1.00	0.92	0.92	0.97	0.92	0.92	1.00	0.92
Lanes:	0.00	0.67	0.33	1.63	0.00	0.37	1.00	2.00	0.00	1.00	2.00	1.00
Final Sat.:	0	1200	600	2857	0	643	1750	3700	0	1750	3800	1750

Capacity Analysis Module:												
Vol/Sat:	0.00	0.00	0.00	0.10	0.00	0.13	0.09	0.32	0.00	0.00	0.17	0.29
Crit Moves:	****			****			****			****		
Green Time:	0.0	10.0	10.0	19.5	0.0	18.9	16.0	63.5	0.0	7.0	54.5	54.5
Volume/Cap:	0.00	0.02	0.02	0.50	0.00	0.67	0.54	0.50	0.00	0.01	0.31	0.54
Uniform Del:	0.0	40.6	40.6	35.9	0.0	37.6	38.6	9.8	0.0	43.3	12.4	14.6
IncremntDel:	0.0	0.0	0.0	0.6	0.0	3.1	2.1	0.2	0.0	0.0	0.1	0.6
InitQueueDel:	0.0	0.0	0.0	0.0	0.0	0.0	0.0	0.0	0.0	0.0	0.0	0.0
Delay Adj:	0.00	1.00	1.00	1.00	0.00	1.00	1.00	1.00	0.00	1.00	1.00	1.00
Delay/Veh:	0.0	40.6	40.6	36.5	0.0	40.7	40.6	9.9	0.0	43.3	12.5	15.3
User DelAdj:	1.00	1.00	1.00	1.00	1.00	1.00	1.00	1.00	1.00	1.00	1.00	1.00
AdjDel/Veh:	0.0	40.6	40.6	36.5	0.0	40.7	40.6	9.9	0.0	43.3	12.5	15.3
LOS by Move:	A	D	D	D+	A	D	D	A	A	D	B	B
HCM2kAvgQ:	0	0	0	6	0	8	4	10	0	0	5	11

Note: Queue reported is the number of cars per lane.

Level of Service Computation Report
2000 HCM Operations Method (Base Volume Alternative)

Intersection #3 Silver Creek Road/Yerba Buena Road

Cycle (sec): 100 Critical Vol./Cap.(X): 0.417
Loss Time (sec): 0 Average Delay (sec/veh): 18.4
Optimal Cycle: 39 Level of Service: B-

Table with columns for Street Name, Approach, Movement, Control, Rights, Min. Green, Y+R, Lanes. Rows include Silver Creek Road and Yerba Buena Road with North and South Bound movements.

Table with columns for Volume Module: Base Vol, Growth Adj, Initial Bse, User Adj, PHF Adj, PHF Volume, Reduct Vol, Reduced Vol, PCE Adj, MLF Adj, Final Volume.

Table with columns for Saturation Flow Module: Sat/Lane, Adjustment, Lanes, Final Sat.

Table with columns for Capacity Analysis Module: Vol/Sat, Crit Moves, Green Time, Volume/Cap, Uniform Del, IncremntDel, InitQueueDel, Delay Adj, Delay/Veh, User DelAdj, AdjDel/Veh, LOS by Move, HCM2kAvgQ.

Note: Queue reported is the number of cars per lane.

Level of Service Computation Report
2000 HCM Operations Method (Base Volume Alternative)

Intersection #4 Nieman Boulevard/Silver Creek Valley Road/Yerba Buena Road

Cycle (sec): 100 Critical Vol./Cap.(X): 0.580
Loss Time (sec): 0 Average Delay (sec/veh): 27.1
Optimal Cycle: 54 Level of Service: C

Table with columns for Street Name, Approach, Movement, Control, Rights, Min. Green, Y+R, Lanes. Rows include Nieman Boulevard and Yerba Buena Road with North and South Bound movements.

Table with columns for Volume Module: Base Vol, Growth Adj, Initial Bse, User Adj, PHF Adj, PHF Volume, Reduct Vol, Reduced Vol, PCE Adj, MLF Adj, Final Volume.

Table with columns for Saturation Flow Module: Sat/Lane, Adjustment, Lanes, Final Sat.

Table with columns for Capacity Analysis Module: Vol/Sat, Crit Moves, Green Time, Volume/Cap, Uniform Del, IncremntDel, InitQueueDel, Delay Adj, Delay/Veh, User DelAdj, AdjDel/Veh, LOS by Move, HCM2kAvgQ.

Note: Queue reported is the number of cars per lane.



Level of Service Computation Report

2000 HCM Operations Method (Base Volume Alternative)

Intersection #5 Byington Drive/Yerba Buena Avenue/Yerba Buena Road

Cycle (sec): 100 Critical Vol./Cap.(X): 0.422
Loss Time (sec): 0 Average Delay (sec/veh): 8.1
Optimal Cycle: 39 Level of Service: A

Table with columns for Street Name, Approach, Movement, Control, Rights, Min. Green, Y+R, Lanes for Byington Drive and Yerba Buena Avenue.

Table with columns for Volume Module, Base Vol, Growth Adj, Initial Bse, User Adj, PHF Adj, PHF Volume, Reduct Vol, Reduced Vol, PCE Adj, MLF Adj, Final Volume.

Table with columns for Sat/Lane, Adjustment, Lanes, Final Sat. for Saturation Flow Module.

Table with columns for Vol/Sat, Crit Moves, Green Time, Volume/Cap, Uniform Del, IncremntDel, InitQueuDel, Delay Adj, Delay/Veh, User DelAdj, AdjDel/Veh, LOS by Move, HCM2kAvgQ for Capacity Analysis Module.

Note: Queue reported is the number of cars per lane.

Level of Service Computation Report

2000 HCM Operations Method (Base Volume Alternative)

Intersection #6 San Felipe Road/Yerba Buena Road

Cycle (sec): 120 Critical Vol./Cap.(X): 0.692
Loss Time (sec): 0 Average Delay (sec/veh): 37.8
Optimal Cycle: 74 Level of Service: D+

Table with columns for Street Name, Approach, Movement, Control, Rights, Min. Green, Y+R, Lanes for San Felipe Road and Yerba Buena Road.

Table with columns for Volume Module, Base Vol, Growth Adj, Initial Bse, User Adj, PHF Adj, PHF Volume, Reduct Vol, Reduced Vol, PCE Adj, MLF Adj, Final Volume.

Table with columns for Sat/Lane, Adjustment, Lanes, Final Sat. for Saturation Flow Module.

Table with columns for Vol/Sat, Crit Moves, Green Time, Volume/Cap, Uniform Del, IncremntDel, InitQueuDel, Delay Adj, Delay/Veh, User DelAdj, AdjDel/Veh, LOS by Move, HCM2kAvgQ for Capacity Analysis Module.

Note: Queue reported is the number of cars per lane.

Level of Service Computation Report
2000 HCM Operations Method (Base Volume Alternative)

Intersection #7 Paseo de Arboles/San Felipe Road

Cycle (sec): 100 Critical Vol./Cap.(X): 0.414
Loss Time (sec): 0 Average Delay (sec/veh): 16.9
Optimal Cycle: 39 Level of Service: B

Table with columns for Street Name, Approach, Movement, Control, Rights, Min. Green, Y+R, Lanes. Rows include San Felipe Road and Paseo de Arboles with North and South Bound movements.

Table for Volume Module showing Base Vol, Growth Adj, Initial Bse, User Adj, PHF Adj, PHF Volume, Reduct Vol, Reduced Vol, PCE Adj, MLF Adj, Final Volume.

Table for Saturation Flow Module showing Sat/Lane, Adjustment, Lanes, Final Sat.

Table for Capacity Analysis Module showing Vol/Sat, Crit Moves, Green Time, Volume/Cap, Uniform Del, IncremntDel, InitQueuDel, Delay Adj, Delay/Veh, User DelAdj, AdjDel/Veh, LOS by Move, HCM2kAvgQ.

Note: Queue reported is the number of cars per lane.

Level of Service Computation Report
2000 HCM Operations Method (Base Volume Alternative)

Intersection #8 Delta Road/San Felipe Road

Cycle (sec): 100 Critical Vol./Cap.(X): 0.359
Loss Time (sec): 0 Average Delay (sec/veh): 16.9
Optimal Cycle: 36 Level of Service: B

Table with columns for Street Name, Approach, Movement, Control, Rights, Min. Green, Y+R, Lanes. Rows include San Felipe Road and Delta Road with North and South Bound movements.

Table for Volume Module showing Base Vol, Growth Adj, Initial Bse, User Adj, PHF Adj, PHF Volume, Reduct Vol, Reduced Vol, PCE Adj, MLF Adj, Final Volume.

Table for Saturation Flow Module showing Sat/Lane, Adjustment, Lanes, Final Sat.

Table for Capacity Analysis Module showing Vol/Sat, Crit Moves, Green Time, Volume/Cap, Uniform Del, IncremntDel, InitQueuDel, Delay Adj, Delay/Veh, User DelAdj, AdjDel/Veh, LOS by Move, HCM2kAvgQ.

Note: Queue reported is the number of cars per lane.

Level of Service Computation Report
2000 HCM Operations Method (Base Volume Alternative)

Intersection #9 Fowler Road/San Felipe Road

Cycle (sec): 100 Critical Vol./Cap.(X): 0.329
Loss Time (sec): 0 Average Delay (sec/veh): 10.5
Optimal Cycle: 34 Level of Service: B+

Table with columns for Street Name (San Felipe Road, Fowler Road), Approach (North Bound, South Bound, East Bound, West Bound), Movement (L, T, R), Control (Protected, Include), Rights, Min. Green, Y+R, and Lanes.

Table for Volume Module showing Base Vol, Growth Adj, Initial Bse, User Adj, PHF Adj, PHF Volume, Reduct Vol, Reduced Vol, PCE Adj, MLF Adj, and Final Volume for each approach.

Table for Saturation Flow Module showing Sat/Lane, Adjustment, Lanes, and Final Sat. for each approach.

Table for Capacity Analysis Module showing Vol/Sat, Crit Moves, Green Time, Volume/Cap, Uniform Del, IncremntDel, InitQueueDel, Delay Adj, Delay/Veh, User DelAdj, AdjDel/Veh, LOS by Move, and HCM2kAvgQ.

Note: Queue reported is the number of cars per lane.

Level of Service Computation Report
2000 HCM Operations Method (Base Volume Alternative)

Intersection #10 San Felipe Road/Yerba Buena Avenue

Cycle (sec): 100 Critical Vol./Cap.(X): 0.656
Loss Time (sec): 0 Average Delay (sec/veh): 19.6
Optimal Cycle: 66 Level of Service: B-

Table with columns for Street Name (San Felipe Road, Yerba Buena Avenue), Approach (North Bound, South Bound, East Bound, West Bound), Movement (L, T, R), Control (Protected, Include), Rights, Min. Green, Y+R, and Lanes.

Table for Volume Module showing Base Vol, Growth Adj, Initial Bse, User Adj, PHF Adj, PHF Volume, Reduct Vol, Reduced Vol, PCE Adj, MLF Adj, and Final Volume for each approach.

Table for Saturation Flow Module showing Sat/Lane, Adjustment, Lanes, and Final Sat. for each approach.

Table for Capacity Analysis Module showing Vol/Sat, Crit Moves, Green Time, Volume/Cap, Uniform Del, IncremntDel, InitQueueDel, Delay Adj, Delay/Veh, User DelAdj, AdjDel/Veh, LOS by Move, and HCM2kAvgQ.

Note: Queue reported is the number of cars per lane.

Level of Service Computation Report  
 2000 HCM Operations Method (Base Volume Alternative)

\*\*\*\*\*  
 Intersection #11 Aborn Road/White Road/San Felipe Road  
 \*\*\*\*\*

Cycle (sec): 155 Critical Vol./Cap.(X): 0.702  
 Loss Time (sec): 0 Average Delay (sec/veh): 49.2  
 Optimal Cycle: 77 Level of Service: D  
 \*\*\*\*\*

Street Name:	San Felipe Road						Aborn Road					
Approach:	North Bound			South Bound			East Bound			West Bound		
Movement:	L	T	R	L	T	R	L	T	R	L	T	R
Control:	Protected			Protected			Protected			Protected		
Rights:	Include			Include			Include			Include		
Min. Green:	7	10	10	7	10	10	7	10	10	7	10	10
Y+R:	4.0	4.0	4.0	4.0	4.0	4.0	4.0	4.0	4.0	4.0	4.0	4.0
Lanes:	2	0	2	0	2	0	1	2	0	3	0	1

Volume Module:

Base Vol:	379	494	84	174	699	323	457	734	447	249	497	120
Growth Adj:	1.00	1.00	1.00	1.00	1.00	1.00	1.00	1.00	1.00	1.00	1.00	1.00
Initial Bse:	379	494	84	174	699	323	457	734	447	249	497	120
User Adj:	1.00	1.00	1.00	1.00	1.00	1.00	1.00	1.00	1.00	1.00	1.00	1.00
PHF Adj:	1.00	1.00	1.00	1.00	1.00	1.00	1.00	1.00	1.00	1.00	1.00	1.00
PHF Volume:	379	494	84	174	699	323	457	734	447	249	497	120
Reduct Vol:	0	0	0	0	0	0	0	0	0	0	0	0
Reduced Vol:	379	494	84	174	699	323	457	734	447	249	497	120
PCE Adj:	1.00	1.00	1.00	1.00	1.00	1.00	1.00	1.00	1.00	1.00	1.00	1.00
MLF Adj:	1.00	1.00	1.00	1.00	1.00	1.00	1.00	1.00	1.00	1.00	1.00	1.00
FinalVolume:	379	494	84	174	699	323	457	734	447	249	497	120

Saturation Flow Module:

Sat/Lane:	1900	1900	1900	1900	1900	1900	1900	1900	1900	1900	1900	1900
Adjustment:	0.83	1.00	0.92	0.83	1.00	0.92	0.83	1.00	0.92	0.92	1.00	0.92
Lanes:	2.00	2.00	1.00	2.00	2.00	1.00	2.00	3.00	1.00	1.00	3.00	1.00
Final Sat.:	3150	3800	1750	3150	3800	1750	3150	5700	1750	1750	5700	1750

Capacity Analysis Module:

Vol/Sat:	0.12	0.13	0.05	0.06	0.18	0.18	0.15	0.13	0.26	0.14	0.09	0.07
Crit Moves:	****			****			****		****	****		
Green Time:	26.6	47.1	47.1	20.0	40.6	40.6	54.9	56.4	56.4	31.4	33.0	33.0
Volume/Cap:	0.70	0.43	0.16	0.43	0.70	0.70	0.41	0.35	0.70	0.70	0.41	0.32
Uniform Del:	60.5	43.1	39.4	62.2	51.7	51.8	37.8	36.0	42.1	57.4	52.6	51.6
IncrcmntDel:	4.1	0.3	0.1	0.7	2.3	4.9	0.2	0.1	3.5	6.2	0.2	0.5
InitQueuDel:	0.0	0.0	0.0	0.0	0.0	0.0	0.0	0.0	0.0	0.0	0.0	0.0
Delay Adj:	1.00	1.00	1.00	1.00	1.00	1.00	1.00	1.00	1.00	1.00	1.00	1.00
Delay/Veh:	64.6	43.4	39.6	62.9	54.0	56.7	38.1	36.1	45.6	63.6	52.9	52.1
User DelAdj:	1.00	1.00	1.00	1.00	1.00	1.00	1.00	1.00	1.00	1.00	1.00	1.00
AdjDel/Veh:	64.6	43.4	39.6	62.9	54.0	56.7	38.1	36.1	45.6	63.6	52.9	52.1
LOS by Move:	E	D	D	E	D-	E+	D+	D+	D	E	D-	D-
HCM2kAvgQ:	10	9	3	5	16	16	9	8	19	13	7	5

Note: Queue reported is the number of cars per lane.  
 \*\*\*\*\*

Level of Service Computation Report  
 2000 HCM Operations Method (Base Volume Alternative)

\*\*\*\*\*  
 Intersection #12 Aborn Road/Nieman Boulevard  
 \*\*\*\*\*

Cycle (sec): 170 Critical Vol./Cap.(X): 0.631  
 Loss Time (sec): 0 Average Delay (sec/veh): 39.2  
 Optimal Cycle: 62 Level of Service: D  
 \*\*\*\*\*

Street Name:	Nieman Boulevard						Aborn Road					
Approach:	North Bound			South Bound			East Bound			West Bound		
Movement:	L	T	R	L	T	R	L	T	R	L	T	R
Control:	Protected			Protected			Protected			Protected		
Rights:	Include			Include			Include			Include		
Min. Green:	7	10	10	7	10	10	7	10	10	7	10	10
Y+R:	4.0	4.0	4.0	4.0	4.0	4.0	4.0	4.0	4.0	4.0	4.0	4.0
Lanes:	1	0	2	0	1	1	1	0	2	0	1	1

Volume Module:

Base Vol:	57	88	137	291	206	72	24	1575	82	159	1053	198
Growth Adj:	1.00	1.00	1.00	1.00	1.00	1.00	1.00	1.00	1.00	1.00	1.00	1.00
Initial Bse:	57	88	137	291	206	72	24	1575	82	159	1053	198
User Adj:	1.00	1.00	1.00	1.00	1.00	1.00	1.00	1.00	1.00	1.00	1.00	1.00
PHF Adj:	1.00	1.00	1.00	1.00	1.00	1.00	1.00	1.00	1.00	1.00	1.00	1.00
PHF Volume:	57	88	137	291	206	72	24	1575	82	159	1053	198
Reduct Vol:	0	0	0	0	0	0	0	0	0	0	0	0
Reduced Vol:	57	88	137	291	206	72	24	1575	82	159	1053	198
PCE Adj:	1.00	1.00	1.00	1.00	1.00	1.00	1.00	1.00	1.00	1.00	1.00	1.00
MLF Adj:	1.00	1.00	1.00	1.00	1.00	1.00	1.00	1.00	1.00	1.00	1.00	1.00
FinalVolume:	57	88	137	291	206	72	24	1575	82	159	1053	198

Saturation Flow Module:

Sat/Lane:	1900	1900	1900	1900	1900	1900	1900	1900	1900	1900	1900	1900
Adjustment:	0.92	1.00	0.92	0.92	1.00	0.92	0.92	0.98	0.95	0.92	1.00	0.92
Lanes:	1.00	2.00	1.00	1.00	2.00	1.00	1.00	2.85	0.15	1.00	3.00	1.00
Final Sat.:	1750	3800	1750	1750	3800	1750	1750	5323	277	1750	5700	1750

Capacity Analysis Module:

Vol/Sat:	0.03	0.02	0.08	0.17	0.05	0.04	0.01	0.30	0.30	0.09	0.18	0.11
Crit Moves:	****		****	****		****	****		****	****		****
Green Time:	27.1	21.1	21.1	44.8	38.7	38.7	19.0	79.7	79.7	24.5	85.2	85.2
Volume/Cap:	0.20	0.19	0.63	0.63	0.24	0.18	0.12	0.63	0.63	0.63	0.37	0.23
Uniform Del:	62.1	66.8	70.8	55.3	53.6	52.8	68.0	34.1	34.1	68.5	26.0	23.9
IncrcmntDel:	0.4	0.2	5.9	2.8	0.1	0.2	0.3	0.5	0.5	5.1	0.1	0.1
InitQueuDel:	0.0	0.0	0.0	0.0	0.0	0.0	0.0	0.0	0.0	0.0	0.0	0.0
Delay Adj:	1.00	1.00	1.00	1.00	1.00	1.00	1.00	1.00	1.00	1.00	1.00	1.00
Delay/Veh:	62.4	67.0	76.7	58.1	53.7	53.1	68.3	34.6	34.6	73.6	26.0	24.0
User DelAdj:	1.00	1.00	1.00	1.00	1.00	1.00	1.00	1.00	1.00	1.00	1.00	1.00
AdjDel/Veh:	62.4	67.0	76.7	58.1	53.7	53.1	68.3	34.6	34.6	73.6	26.0	24.0
LOS by Move:	E	E	E-	E+	D-	D-	E	C-	C-	E	C	C
HCM2kAvgQ:	3	2	8	15	4	3	1	20	20	8	11	6

Note: Queue reported is the number of cars per lane.  
 \*\*\*\*\*

Level of Service Computation Report
2000 HCM Operations Method (Base Volume Alternative)

Intersection #13 Capitol Expressway/Aborn Road

Cycle (sec): 190 Critical Vol./Cap.(X): 1.049
Loss Time (sec): 0 Average Delay (sec/veh): 67.2
Optimal Cycle: 180 Level of Service: E

Table with columns for Street Name, Approach, Movement, Control, Rights, Min. Green, Y+R, Lanes. Rows include Capitol Expresswa and Aborn Road with North, South, East, and West bound movements.

Table with columns for Volume Module: Base Vol, Growth Adj, Initial Bse, User Adj, PHF Adj, PHF Volume, Reduct Vol, Reduced Vol, PCE Adj, MLF Adj, Final Volume.

Table with columns for Saturation Flow Module: Sat/Lane, Adjustment, Lanes, Final Sat.

Table with columns for Capacity Analysis Module: Vol/Sat, Crit Moves, Green Time, Volume/Cap, Uniform Del, IncremntDel, InitQueuDel, Delay Adj, Delay/Veh, User DelAdj, AdjDel/Veh, LOS by Move, HCM2kAvgQ.

Note: Queue reported is the number of cars per lane.

Level of Service Computation Report
2000 HCM Operations Method (Base Volume Alternative)

Intersection #14 Capitol Expressway/Silver Creek Road

Cycle (sec): 190 Critical Vol./Cap.(X): 0.830
Loss Time (sec): 0 Average Delay (sec/veh): 52.0
Optimal Cycle: 134 Level of Service: D-

Table with columns for Street Name, Approach, Movement, Control, Rights, Min. Green, Y+R, Lanes. Rows include Capitol Expresswa and Silver Creek Road with North, South, East, and West bound movements.

Table with columns for Volume Module: Base Vol, Growth Adj, Initial Bse, User Adj, PHF Adj, PHF Volume, Reduct Vol, Reduced Vol, PCE Adj, MLF Adj, Final Volume.

Table with columns for Saturation Flow Module: Sat/Lane, Adjustment, Lanes, Final Sat.

Table with columns for Capacity Analysis Module: Vol/Sat, Crit Moves, Green Time, Volume/Cap, Uniform Del, IncremntDel, InitQueuDel, Delay Adj, Delay/Veh, User DelAdj, AdjDel/Veh, LOS by Move, HCM2kAvgQ.

Note: Queue reported is the number of cars per lane.

-----  
 Scenario Report  
 Scenario: Existing Plus Project AM

Command: Default Command  
 Volume: Existing AM  
 Geometry: Existing  
 Impact Fee: Default Impact Fee  
 Trip Generation: Project AM  
 Trip Distribution: Project  
 Paths: Project  
 Routes: Default Route  
 Configuration: Default Configuration

-----  
 Impact Analysis Report  
 Level Of Service

Intersection	Base		Future		Change in
	Del/	V/	Del/	V/	
	LOS	Veh C	LOS	Veh C	
# 1 U.S. 101 SB Off-ramp/Yerba Bue	C	29.7 0.718	C	30.6 0.747	+ 0.897 D/V
# 2 U.S. 101 NB Off-ramp/Yerba Bue	B	15.2 0.433	B	15.8 0.442	+ 0.581 D/V
# 3 Silver Creek Road/Yerba Buena	B-	18.3 0.521	B-	18.3 0.528	-0.019 D/V
# 4 Nieman Boulevard/Silver Creek	C	27.5 0.605	C	28.0 0.656	+ 0.514 D/V
# 5 Byington Drive/Yerba Buena Ave	A	9.6 0.421	A	9.3 0.458	-0.357 D/V
# 6 San Felipe Road/Yerba Buena Ro	D+	38.1 0.736	D	39.7 0.789	+ 1.554 D/V
# 7 Paseo de Arboles/San Felipe Ro	B	15.1 0.402	B	14.5 0.460	-0.524 D/V
# 8 Delta Road/San Felipe Road	B-	19.6 0.461	B-	19.1 0.482	-0.447 D/V
# 9 Fowler Road/San Felipe Road	B	15.3 0.359	B	14.7 0.380	-0.649 D/V
# 10 San Felipe Road/Yerba Buena Av	C+	20.8 0.562	C+	20.3 0.584	-0.442 D/V
# 11 Aborn Road/White Road/San Feli	D	48.2 0.742	D	48.7 0.777	+ 0.444 D/V
# 12 Aborn Road/Nieman Boulevard	D	39.1 0.472	D	40.6 0.492	+ 1.543 D/V
# 13 Capitol Expressway/Aborn Road	D-	54.6 0.895	D-	54.6 0.895	+ 0.036 D/V
# 14 Capitol Expressway/Silver Cree	D-	54.5 0.875	D-	54.6 0.877	+ 0.087 D/V

## Level Of Service Computation Report

## 2000 HCM Operations Method (Future Volume Alternative)

\*\*\*\*\*  
 Intersection #1 U.S. 101 SB Off-ramp/Yerba Buena Road  
 \*\*\*\*\*

Cycle (sec): 100 Critical Vol./Cap.(X): 0.747  
 Loss Time (sec): 0 Average Delay (sec/veh): 30.6  
 Optimal Cycle: 90 Level Of Service: C  
 \*\*\*\*\*

Street Name:	U.S. 101 SB Off-ramp						Yerba Buena Road					
Approach:	North Bound			South Bound			East Bound			West Bound		
Movement:	L	T	R	L	T	R	L	T	R	L	T	R
Control:	Protected			Protected			Protected			Protected		
Rights:	Include			Include			Include			Include		
Min. Green:	7	10	10	7	10	10	7	10	10	7	10	10
Y+R:	4.0	4.0	4.0	4.0	4.0	4.0	4.0	4.0	4.0	4.0	4.0	4.0
Lanes:	0	0	0	0	0	0	0	0	2	0	1	0

Volume Module:	U.S. 101 SB Off-ramp			U.S. 101 SB Off-ramp			Yerba Buena Road			Yerba Buena Road		
Base Vol:	0	0	0	563	1	147	0	581	105	426	660	0
Growth Adj:	1.00	1.00	1.00	1.00	1.00	1.00	1.00	1.00	1.00	1.00	1.00	1.00
Initial Bse:	0	0	0	563	1	147	0	581	105	426	660	0
Added Vol:	0	0	0	43	0	0	0	5	0	6	1	0
PasserByVol:	0	0	0	0	0	0	0	0	0	0	0	0
Initial Fut:	0	0	0	606	1	147	0	586	105	432	661	0
User Adj:	1.00	1.00	1.00	1.00	1.00	1.00	1.00	1.00	1.00	1.00	1.00	1.00
PHF Adj:	1.00	1.00	1.00	1.00	1.00	1.00	1.00	1.00	1.00	1.00	1.00	1.00
PHF Volume:	0	0	0	606	1	147	0	586	105	432	661	0
Reduct Vol:	0	0	0	0	0	0	0	0	0	0	0	0
Reduced Vol:	0	0	0	606	1	147	0	586	105	432	661	0
PCE Adj:	1.00	1.00	1.00	1.00	1.00	1.00	1.00	1.00	1.00	1.00	1.00	1.00
MLF Adj:	1.00	1.00	1.00	1.00	1.00	1.00	1.00	1.00	1.00	1.00	1.00	1.00
FinalVolume:	0	0	0	606	1	147	0	586	105	432	661	0

Saturation Flow Module:	U.S. 101 SB Off-ramp			U.S. 101 SB Off-ramp			Yerba Buena Road			Yerba Buena Road		
Sat/Lane:	1900	1900	1900	1900	1900	1900	1900	1900	1900	1900	1900	1900
Adjustment:	0.92	1.00	0.92	0.92	0.95	0.95	0.92	1.00	0.92	0.92	1.00	0.92
Lanes:	0.00	0.00	0.00	1.00	0.01	0.99	0.00	2.00	1.00	1.00	2.00	0.00
Final Sat.:	0	0	0	1750	12	1788	0	3800	1750	1750	3800	0

Capacity Analysis Module:	U.S. 101 SB Off-ramp			U.S. 101 SB Off-ramp			Yerba Buena Road			Yerba Buena Road		
Vol/Sat:	0.00	0.00	0.00	0.35	0.08	0.08	0.00	0.15	0.06	0.25	0.17	0.00
Crit Moves:	****			****			****			****		
Green Time:	0.0	0.0	0.0	46.3	33.1	33.1	0.0	20.6	20.6	33.0	38.3	0.0
Volume/Cap:	0.00	0.00	0.00	0.75	0.25	0.25	0.00	0.75	0.29	0.75	0.45	0.00
Uniform Del:	0.0	0.0	0.0	22.0	24.4	24.4	0.0	37.2	33.5	29.8	23.1	0.0
IncrementDel:	0.0	0.0	0.0	3.9	0.2	0.2	0.0	4.0	0.4	5.3	0.2	0.0
InitQueueDel:	0.0	0.0	0.0	0.0	0.0	0.0	0.0	0.0	0.0	0.0	0.0	0.0
Delay Adj:	0.00	0.00	0.00	1.00	1.00	1.00	0.00	1.00	1.00	1.00	1.00	0.00
Delay/Veh:	0.0	0.0	0.0	25.9	24.6	24.6	0.0	41.2	34.0	35.1	23.3	0.0
User DelAdj:	1.00	1.00	1.00	1.00	1.00	1.00	1.00	1.00	1.00	1.00	1.00	1.00
AdjDel/Veh:	0.0	0.0	0.0	25.9	24.6	24.6	0.0	41.2	34.0	35.1	23.3	0.0
LOS by Move:	A	A	A	C	C	C	A	D	C-	D+	C	A
HCM2kAvgQ:	0	0	0	18	3	3	0	10	3	13	7	0

\*\*\*\*\*  
 Note: Queue reported is the number of cars per lane.  
 \*\*\*\*\*

## Level of Service Computation Report

## 2000 HCM Operations Method (Future Volume Alternative)

\*\*\*\*\*  
 Intersection #2 U.S. 101 NB Off-ramp/Yerba Buena Road  
 \*\*\*\*\*

Cycle (sec): 100 Critical Vol./Cap.(X): 0.442  
 Loss Time (sec): 0 Average Delay (sec/veh): 15.8  
 Optimal Cycle: 41 Level of Service: B  
 \*\*\*\*\*

Street Name:	U.S. 101 NB Off-ram						Yerba Buena Road					
Approach:	North Bound			South Bound			East Bound			West Bound		
Movement:	L	T	R	L	T	R	L	T	R	L	T	R
Control:	Protected			Protected			Protected			Protected		
Rights:	Include			Include			Include			Include		
Min. Green:	7	10	10	7	10	10	7	10	10	7	10	10
Y+R:	4.0	4.0	4.0	4.0	4.0	4.0	4.0	4.0	4.0	4.0	4.0	4.0
Lanes:	0	0	0	0	1	0	1	0	1	0	1	0

Volume Module:												
Base Vol:	0	0	1	120	1	64	167	981	0	0	1012	305
Growth Adj:	1.00	1.00	1.00	1.00	1.00	1.00	1.00	1.00	1.00	1.00	1.00	1.00
Initial Bse:	0	0	1	120	1	64	167	981	0	0	1012	305
Added Vol:	0	0	0	25	0	0	0	48	0	0	8	11
PasserByVol:	0	0	0	0	0	0	0	0	0	0	0	0
Initial Fut:	0	0	1	145	1	64	167	1029	0	0	1020	316
User Adj:	1.00	1.00	1.00	1.00	1.00	1.00	1.00	1.00	1.00	1.00	1.00	1.00
PHF Adj:	1.00	1.00	1.00	1.00	1.00	1.00	1.00	1.00	1.00	1.00	1.00	1.00
PHF Volume:	0	0	1	145	1	64	167	1029	0	0	1020	316
Reduct Vol:	0	0	0	0	0	0	0	0	0	0	0	0
Reduced Vol:	0	0	1	145	1	64	167	1029	0	0	1020	316
PCE Adj:	1.00	1.00	1.00	1.00	1.00	1.00	1.00	1.00	1.00	1.00	1.00	1.00
MLF Adj:	1.00	1.00	1.00	1.00	1.00	1.00	1.00	1.00	1.00	1.00	1.00	1.00
FinalVolume:	0	0	1	145	1	64	167	1029	0	0	1020	316

Saturation Flow Module:												
Sat/Lane:	1900	1900	1900	1900	1900	1900	1900	1900	1900	1900	1900	1900
Adjustment:	0.92	1.00	0.92	0.92	0.92	0.92	0.92	0.97	0.92	0.92	1.00	0.92
Lanes:	0.00	0.00	1.00	1.53	0.01	0.46	1.00	2.00	0.00	1.00	2.00	1.00
Final Sat.:	0	0	1750	2673	13	815	1750	3700	0	1750	3800	1750

Capacity Analysis Module:												
Vol/Sat:	0.00	0.00	0.00	0.05	0.08	0.08	0.10	0.28	0.00	0.00	0.27	0.18
Crit Moves:	****			****			****			****		
Green Time:	0.0	0.0	7.0	9.7	16.5	16.5	20.1	61.1	0.0	0.0	56.4	56.4
Volume/Cap:	0.00	0.00	0.01	0.56	0.48	0.48	0.48	0.46	0.00	0.00	0.48	0.32
Uniform Del:	0.0	0.0	43.3	43.1	37.8	37.8	35.3	10.5	0.0	0.0	13.0	11.6
IncrementDel:	0.0	0.0	0.0	1.9	0.8	0.8	1.0	0.1	0.0	0.0	0.2	0.2
InitQueueDel:	0.0	0.0	0.0	0.0	0.0	0.0	0.0	0.0	0.0	0.0	0.0	0.0
Delay Adj:	0.00	0.00	1.00	1.00	1.00	1.00	1.00	1.00	0.00	0.00	1.00	1.00
Delay/Veh:	0.0	0.0	43.3	45.0	38.6	38.6	36.3	10.6	0.0	0.0	13.1	11.8
User DelAdj:	1.00	1.00	1.00	1.00	1.00	1.00	1.00	1.00	1.00	1.00	1.00	1.00
AdjDel/Veh:	0.0	0.0	43.3	45.0	38.6	38.6	36.3	10.6	0.0	0.0	13.1	11.8
LOS by Move:	A	A	D	D	D+	D+	D+	B+	A	A	B	B+
HCM2kAvgQ:	0	0	0	4	5	5	5	8	0	0	9	5

\*\*\*\*\*  
 Note: Queue reported is the number of cars per lane.  
 \*\*\*\*\*



## Level of Service Computation Report

2000 HCM Operations Method (Future Volume Alternative)

\*\*\*\*\*  
Intersection #3 Silver Creek Road/Yerba Buena Road  
\*\*\*\*\*

Cycle (sec): 100 Critical Vol./Cap.(X): 0.528  
 Loss Time (sec): 0 Average Delay (sec/veh): 18.3  
 Optimal Cycle: 48 Level of Service: B-  
 \*\*\*\*\*

Street Name:	Silver Creek Road						Yerba Buena Road					
Approach:	North Bound			South Bound			East Bound			West Bound		
Movement:	L	T	R	L	T	R	L	T	R	L	T	R
Control:	Protected			Protected			Protected			Protected		
Rights:	Include			Include			Include			Include		
Min. Green:	7	10	10	7	10	10	7	10	10	7	10	10
Y+R:	4.0	4.0	4.0	4.0	4.0	4.0	4.0	4.0	4.0	4.0	4.0	4.0
Lanes:	1	0	1	0	1	1	2	0	1	1	0	1

Volume Module:	Silver Creek Road			Silver Creek Road			Yerba Buena Road			Yerba Buena Road		
Base Vol:	44	46	65	161	19	169	175	853	30	44	967	303
Growth Adj:	1.00	1.00	1.00	1.00	1.00	1.00	1.00	1.00	1.00	1.00	1.00	1.00
Initial Bse:	44	46	65	161	19	169	175	853	30	44	967	303
Added Vol:	0	0	0	26	0	0	0	73	0	0	19	7
PasserByVol:	0	0	0	0	0	0	0	0	0	0	0	0
Initial Fut:	44	46	65	187	19	169	175	926	30	44	986	310
User Adj:	1.00	1.00	1.00	1.00	1.00	1.00	1.00	1.00	1.00	1.00	1.00	1.00
PHF Adj:	1.00	1.00	1.00	1.00	1.00	1.00	1.00	1.00	1.00	1.00	1.00	1.00
PHF Volume:	44	46	65	187	19	169	175	926	30	44	986	310
Reduct Vol:	0	0	0	0	0	0	0	0	0	0	0	0
Reduced Vol:	44	46	65	187	19	169	175	926	30	44	986	310
PCE Adj:	1.00	1.00	1.00	1.00	1.00	1.00	1.00	1.00	1.00	1.00	1.00	1.00
MLF Adj:	1.00	1.00	1.00	1.00	1.00	1.00	1.00	1.00	1.00	1.00	1.00	1.00
FinalVolume:	44	46	65	187	19	169	175	926	30	44	986	310

Saturation Flow Module:	Silver Creek Road			Silver Creek Road			Yerba Buena Road			Yerba Buena Road		
Sat/Lane:	1900	1900	1900	1900	1900	1900	1900	1900	1900	1900	1900	1900
Adjustment:	0.92	1.00	0.92	0.93	0.95	0.92	0.83	0.97	0.95	0.92	0.98	0.95
Lanes:	1.00	1.00	1.00	1.82	0.18	1.00	2.00	1.94	0.06	1.00	1.51	0.49
Final Sat.:	1750	1900	1750	3223	327	1750	3150	3584	116	1750	2814	885

Capacity Analysis Module:	Silver Creek Road			Silver Creek Road			Yerba Buena Road			Yerba Buena Road		
Vol/Sat:	0.03	0.02	0.04	0.06	0.06	0.10	0.06	0.26	0.26	0.03	0.35	0.35
Crit Moves:	****			****		****	****		****	****		****
Green Time:	7.0	14.6	14.6	10.2	17.9	17.9	10.3	59.1	59.1	16.0	64.8	64.8
Volume/Cap:	0.36	0.17	0.25	0.57	0.32	0.54	0.54	0.44	0.44	0.16	0.54	0.54
Uniform Del:	44.4	37.3	37.8	42.8	35.8	37.3	42.6	11.3	11.3	36.2	9.5	9.5
IncrementDel:	1.8	0.3	0.5	2.1	0.3	1.9	1.8	0.1	0.1	0.3	0.3	0.3
InitQueueDel:	0.0	0.0	0.0	0.0	0.0	0.0	0.0	0.0	0.0	0.0	0.0	0.0
Delay Adj:	1.00	1.00	1.00	1.00	1.00	1.00	1.00	1.00	1.00	1.00	1.00	1.00
Delay/Veh:	46.2	37.6	38.4	44.9	36.1	39.2	44.5	11.4	11.4	36.4	9.8	9.8
User DelAdj:	1.00	1.00	1.00	1.00	1.00	1.00	1.00	1.00	1.00	1.00	1.00	1.00
AdjDel/Veh:	46.2	37.6	38.4	44.9	36.1	39.2	44.5	11.4	11.4	36.4	9.8	9.8
LOS by Move:	D	D+	D+	D	D+	D	D	B+	B+	D+	A	A
HCM2kAvgQ:	2	1	2	4	3	6	3	8	8	1	11	11

\*\*\*\*\*  
 Note: Queue reported is the number of cars per lane.  
 \*\*\*\*\*

## Level of Service Computation Report

## 2000 HCM Operations Method (Future Volume Alternative)

\*\*\*\*\*  
 Intersection #4 Nieman Boulevard/Silver Creek Valley Road/Yerba Buena Road  
 \*\*\*\*\*

Cycle (sec): 100 Critical Vol./Cap.(X): 0.656  
 Loss Time (sec): 0 Average Delay (sec/veh): 28.0  
 Optimal Cycle: 66 Level of Service: C  
 \*\*\*\*\*

Street Name:	Nieman Boulevard						Yerba Buena Road					
	North Bound			South Bound			East Bound			West Bound		
Approach:	North Bound			South Bound			East Bound			West Bound		
Movement:	L	T	R	L	T	R	L	T	R	L	T	R
Control:	Protected			Protected			Protected			Protected		
Rights:	Include			Include			Include			Include		
Min. Green:	7	10	10	7	10	10	7	10	10	7	10	10
Y+R:	4.0	4.0	4.0	4.0	4.0	4.0	4.0	4.0	4.0	4.0	4.0	4.0
Lanes:	1	0	2	0	1	1	1	0	2	0	1	1

Volume Module:												
Base Vol:	227	281	401	89	185	100	25	833	152	186	773	112
Growth Adj:	1.00	1.00	1.00	1.00	1.00	1.00	1.00	1.00	1.00	1.00	1.00	1.00
Initial Bse:	227	281	401	89	185	100	25	833	152	186	773	112
Added Vol:	0	0	25	11	0	0	0	100	0	6	25	3
PasserByVol:	0	0	0	0	0	0	0	0	0	0	0	0
Initial Fut:	227	281	426	100	185	100	25	933	152	192	798	115
User Adj:	1.00	1.00	1.00	1.00	1.00	1.00	1.00	1.00	1.00	1.00	1.00	1.00
PHF Adj:	1.00	1.00	1.00	1.00	1.00	1.00	1.00	1.00	1.00	1.00	1.00	1.00
PHF Volume:	227	281	426	100	185	100	25	933	152	192	798	115
Reduct Vol:	0	0	0	0	0	0	0	0	0	0	0	0
Reduced Vol:	227	281	426	100	185	100	25	933	152	192	798	115
PCE Adj:	1.00	1.00	1.00	1.00	1.00	1.00	1.00	1.00	1.00	1.00	1.00	1.00
MLF Adj:	1.00	1.00	1.00	1.00	1.00	1.00	1.00	1.00	1.00	1.00	1.00	1.00
FinalVolume:	227	281	426	100	185	100	25	933	152	192	798	115

Saturation Flow Module:												
Sat/Lane:	1900	1900	1900	1900	1900	1900	1900	1900	1900	1900	1900	1900
Adjustment:	0.92	1.00	0.92	0.92	1.00	0.92	0.92	1.00	0.92	0.92	1.00	0.92
Lanes:	1.00	2.00	1.00	1.00	2.00	1.00	1.00	2.00	1.00	1.00	2.00	1.00
Final Sat.:	1750	3800	1750	1750	3800	1750	1750	3800	1750	1750	3800	1750

Capacity Analysis Module:												
Vol/Sat:	0.13	0.07	0.24	0.06	0.05	0.06	0.01	0.25	0.09	0.11	0.21	0.07
Crit Moves:	****			****			****			****		
Green Time:	25.9	37.1	37.1	8.7	20.0	20.0	13.5	37.4	37.4	16.7	40.6	40.6
Volume/Cap:	0.50	0.20	0.66	0.66	0.24	0.29	0.11	0.66	0.23	0.66	0.52	0.16
Uniform Del:	31.6	21.3	26.1	44.2	33.7	34.0	37.9	25.9	21.4	38.9	22.3	18.9
IncrementDel:	0.9	0.1	2.4	9.9	0.2	0.5	0.2	1.1	0.2	5.3	0.3	0.1
InitQueueDel:	0.0	0.0	0.0	0.0	0.0	0.0	0.0	0.0	0.0	0.0	0.0	0.0
Delay Adj:	1.00	1.00	1.00	1.00	1.00	1.00	1.00	1.00	1.00	1.00	1.00	1.00
Delay/Veh:	32.4	21.4	28.6	54.1	33.8	34.4	38.1	27.1	21.6	44.3	22.6	19.0
User DelAdj:	1.00	1.00	1.00	1.00	1.00	1.00	1.00	1.00	1.00	1.00	1.00	1.00
AdjDel/Veh:	32.4	21.4	28.6	54.1	33.8	34.4	38.1	27.1	21.6	44.3	22.6	19.0
LOS by Move:	C-	C+	C	D-	C-	C-	D+	C	C+	D	C+	B-
HCM2kAvgQ:	7	3	12	4	2	3	1	12	3	6	9	2

\*\*\*\*\*  
 Note: Queue reported is the number of cars per lane.  
 \*\*\*\*\*

## Level of Service Computation Report

## 2000 HCM Operations Method (Future Volume Alternative)

\*\*\*\*\*  
Intersection #5 Byington Drive/Yerba Buena Avenue/Yerba Buena Road  
\*\*\*\*\*

Cycle (sec): 100 Critical Vol./Cap.(X): 0.458  
 Loss Time (sec): 0 Average Delay (sec/veh): 9.3  
 Optimal Cycle: 42 Level of Service: A  
 \*\*\*\*\*

Street Name:	Byington Drive						Yerba Buena Avenue					
Approach:	North Bound			South Bound			East Bound			West Bound		
Movement:	L	T	R	L	T	R	L	T	R	L	T	R
Control:	Protected			Protected			Protected			Protected		
Rights:	Include			Include			Include			Include		
Min. Green:	7	10	10	7	10	10	7	10	10	7	10	10
Y+R:	4.0	4.0	4.0	4.0	4.0	4.0	4.0	4.0	4.0	4.0	4.0	4.0
Lanes:	0	0	1	0	0	1	1	0	1	1	0	1

## Volume Module:

Base Vol:	11	0	16	35	0	67	18	1255	7	11	998	11
Growth Adj:	1.00	1.00	1.00	1.00	1.00	1.00	1.00	1.00	1.00	1.00	1.00	1.00
Initial Bse:	11	0	16	35	0	67	18	1255	7	11	998	11
Added Vol:	0	0	0	0	0	0	0	136	0	0	35	0
PasserByVol:	0	0	0	0	0	0	0	0	0	0	0	0
Initial Fut:	11	0	16	35	0	67	18	1391	7	11	1033	11
User Adj:	1.00	1.00	1.00	1.00	1.00	1.00	1.00	1.00	1.00	1.00	1.00	1.00
PHF Adj:	1.00	1.00	1.00	1.00	1.00	1.00	1.00	1.00	1.00	1.00	1.00	1.00
PHF Volume:	11	0	16	35	0	67	18	1391	7	11	1033	11
Reduct Vol:	0	0	0	0	0	0	0	0	0	0	0	0
Reduced Vol:	11	0	16	35	0	67	18	1391	7	11	1033	11
PCE Adj:	1.00	1.00	1.00	1.00	1.00	1.00	1.00	1.00	1.00	1.00	1.00	1.00
MLF Adj:	1.00	1.00	1.00	1.00	1.00	1.00	1.00	1.00	1.00	1.00	1.00	1.00
FinalVolume:	11	0	16	35	0	67	18	1391	7	11	1033	11

## Saturation Flow Module:

Sat/Lane:	1900	1900	1900	1900	1900	1900	1900	1900	1900	1900	1900	1900
Adjustment:	0.92	0.92	0.92	0.92	0.92	0.92	0.92	0.97	0.95	0.92	0.97	0.95
Lanes:	0.41	0.00	0.59	0.34	0.00	0.66	1.00	1.99	0.01	1.00	1.98	0.02
Final Sat.:	713	0	1037	600	0	1150	1750	3681	19	1750	3661	39

## Capacity Analysis Module:

Vol/Sat:	0.02	0.00	0.02	0.06	0.00	0.06	0.01	0.38	0.38	0.01	0.28	0.28
Crit Moves:	****			****		****	****		****	****		****
Green Time:	7.0	0.0	7.0	7.6	0.0	11.5	16.2	74.5	74.5	7.0	65.3	65.3
Volume/Cap:	0.22	0.00	0.22	0.77	0.00	0.51	0.06	0.51	0.51	0.09	0.43	0.43
Uniform Del:	43.9	0.0	43.9	45.3	0.0	41.6	35.5	5.2	5.2	43.5	8.4	8.4
IncrementDel:	0.9	0.0	0.9	22.9	0.0	2.1	0.1	0.2	0.2	0.3	0.1	0.1
InitQueueDel:	0.0	0.0	0.0	0.0	0.0	0.0	0.0	0.0	0.0	0.0	0.0	0.0
Delay Adj:	1.00	0.00	1.00	1.00	0.00	1.00	1.00	1.00	1.00	1.00	1.00	1.00
Delay/Veh:	44.8	0.0	44.8	68.2	0.0	43.7	35.6	5.4	5.4	43.8	8.5	8.5
User DelAdj:	1.00	1.00	1.00	1.00	1.00	1.00	1.00	1.00	1.00	1.00	1.00	1.00
AdjDel/Veh:	44.8	0.0	44.8	68.2	0.0	43.7	35.6	5.4	5.4	43.8	8.5	8.5
LOS by Move:	D	A	D	E	A	D	D+	A	A	D	A	A
HCM2kAvgQ:	1	0	1	5	0	4	0	9	9	0	8	8

\*\*\*\*\*  
 Note: Queue reported is the number of cars per lane.  
 \*\*\*\*\*

## Level of Service Computation Report

## 2000 HCM Operations Method (Future Volume Alternative)

\*\*\*\*\*  
Intersection #6 San Felipe Road/Yerba Buena Road  
\*\*\*\*\*

Cycle (sec): 120 Critical Vol./Cap.(X): 0.789  
 Loss Time (sec): 0 Average Delay (sec/veh): 39.7  
 Optimal Cycle: 108 Level of Service: D  
 \*\*\*\*\*

Street Name:	San Felipe Road						Yerba Buena Road					
Approach:	North Bound			South Bound			East Bound			West Bound		
Movement:	L	T	R	L	T	R	L	T	R	L	T	R
Control:	Protected			Protected			Protected			Protected		
Rights:	Include			Include			Include			Include		
Min. Green:	7	10	10	7	10	10	7	10	10	7	10	10
Y+R:	4.0	4.0	4.0	4.0	4.0	4.0	4.0	4.0	4.0	4.0	4.0	4.0
Lanes:	2	0	2	0	1	1	1	0	2	0	1	1

## Volume Module:

Base Vol:	259	400	81	204	195	444	568	638	124	72	288	71
Growth Adj:	1.00	1.00	1.00	1.00	1.00	1.00	1.00	1.00	1.00	1.00	1.00	1.00
Initial Bse:	259	400	81	204	195	444	568	638	124	72	288	71
Added Vol:	0	13	13	42	3	17	68	68	0	3	17	15
PasserByVol:	0	0	0	0	0	0	0	0	0	0	0	0
Initial Fut:	259	413	94	246	198	461	636	706	124	75	305	86
User Adj:	1.00	1.00	1.00	1.00	1.00	1.00	1.00	1.00	1.00	1.00	1.00	1.00
PHF Adj:	1.00	1.00	1.00	1.00	1.00	1.00	1.00	1.00	1.00	1.00	1.00	1.00
PHF Volume:	259	413	94	246	198	461	636	706	124	75	305	86
Reduct Vol:	0	0	0	0	0	0	0	0	0	0	0	0
Reduced Vol:	259	413	94	246	198	461	636	706	124	75	305	86
PCE Adj:	1.00	1.00	1.00	1.00	1.00	1.00	1.00	1.00	1.00	1.00	1.00	1.00
MLF Adj:	1.00	1.00	1.00	1.00	1.00	1.00	1.00	1.00	1.00	1.00	1.00	1.00
FinalVolume:	259	413	94	246	198	461	636	706	124	75	305	86

## Saturation Flow Module:

Sat/Lane:	1900	1900	1900	1900	1900	1900	1900	1900	1900	1900	1900	1900
Adjustment:	0.83	1.00	0.92	0.92	1.00	0.92	0.92	1.00	0.92	0.92	1.00	0.92
Lanes:	2.00	2.00	1.00	1.00	2.00	1.00	1.00	2.00	1.00	1.00	2.00	1.00
Final Sat.:	3150	3800	1750	1750	3800	1750	1750	3800	1750	1750	3800	1750

## Capacity Analysis Module:

Vol/Sat:	0.08	0.11	0.05	0.14	0.05	0.26	0.36	0.19	0.07	0.04	0.08	0.05
Crit Moves:	****					****	****			****		
Green Time:	12.5	22.9	22.9	29.6	40.0	40.0	55.3	51.3	51.3	16.1	12.2	12.2
Volume/Cap:	0.79	0.57	0.28	0.57	0.16	0.79	0.79	0.43	0.17	0.32	0.79	0.48
Uniform Del:	52.5	44.1	41.5	39.6	28.1	36.2	27.4	24.1	21.1	47.0	52.6	50.9
IncrementDel:	12.1	1.1	0.5	1.8	0.1	7.1	5.3	0.2	0.1	0.8	10.5	2.1
InitQueueDel:	0.0	0.0	0.0	0.0	0.0	0.0	0.0	0.0	0.0	0.0	0.0	0.0
Delay Adj:	1.00	1.00	1.00	1.00	1.00	1.00	1.00	1.00	1.00	1.00	1.00	1.00
Delay/Veh:	64.6	45.1	42.0	41.4	28.2	43.3	32.7	24.3	21.2	47.8	63.1	53.0
User DelAdj:	1.00	1.00	1.00	1.00	1.00	1.00	1.00	1.00	1.00	1.00	1.00	1.00
AdjDel/Veh:	64.6	45.1	42.0	41.4	28.2	43.3	32.7	24.3	21.2	47.8	63.1	53.0
LOS by Move:	E	D	D	D	C	D	C-	C	C+	D	E	D-
HCM2kAvgQ:	8	7	3	9	3	18	22	9	3	3	7	4

\*\*\*\*\*  
 Note: Queue reported is the number of cars per lane.  
 \*\*\*\*\*

Level Of Service Computation Report  
 2000 HCM Operations Method (Future Volume Alternative)

\*\*\*\*\*  
 Intersection #7 Paseo de Arboles/San Felipe Road  
 \*\*\*\*\*

Cycle (sec): 100 Critical Vol./Cap.(X): 0.460  
 Loss Time (sec): 0 Average Delay (sec/veh): 14.5  
 Optimal Cycle: 42 Level Of Service: B  
 \*\*\*\*\*

Street Name:	San Felipe Road						Paseo de Arboles					
Approach:	North Bound			South Bound			East Bound			West Bound		
Movement:	L	T	R	L	T	R	L	T	R	L	T	R
Control:	Protected			Protected			Protected			Protected		
Rights:	Include			Include			Include			Include		
Min. Green:	7	10	10	7	10	10	7	10	10	7	10	10
Y+R:	4.0	4.0	4.0	4.0	4.0	4.0	4.0	4.0	4.0	4.0	4.0	4.0
Lanes:	1	0	2	0	1	1	0	0	0	0	0	1

Volume Module:

Base Vol:	39	691	297	335	915	0	0	0	0	25	0	51
Growth Adj:	1.00	1.00	1.00	1.00	1.00	1.00	1.00	1.00	1.00	1.00	1.00	1.00
Initial Bse:	39	691	297	335	915	0	0	0	0	25	0	51
Added Vol:	0	10	86	40	40	0	0	0	0	22	0	10
PasserByVol:	0	0	0	0	0	0	0	0	0	0	0	0
Initial Fut:	39	701	383	375	955	0	0	0	0	47	0	61
User Adj:	1.00	1.00	1.00	1.00	1.00	1.00	1.00	1.00	1.00	1.00	1.00	1.00
PHF Adj:	1.00	1.00	1.00	1.00	1.00	1.00	1.00	1.00	1.00	1.00	1.00	1.00
PHF Volume:	39	701	383	375	955	0	0	0	0	47	0	61
Reduct Vol:	0	0	0	0	0	0	0	0	0	0	0	0
Reduced Vol:	39	701	383	375	955	0	0	0	0	47	0	61
PCE Adj:	1.00	1.00	1.00	1.00	1.00	1.00	1.00	1.00	1.00	1.00	1.00	1.00
MLF Adj:	1.00	1.00	1.00	1.00	1.00	1.00	1.00	1.00	1.00	1.00	1.00	1.00
FinalVolume:	39	701	383	375	955	0	0	0	0	47	0	61

Saturation Flow Module:

Sat/Lane:	1900	1900	1900	1900	1900	1900	1900	1900	1900	1900	1900	1900
Adjustment:	0.92	1.00	0.92	0.92	1.00	0.92	0.92	1.00	0.92	0.92	1.00	0.92
Lanes:	1.00	2.00	1.00	1.00	2.00	0.00	0.00	0.00	0.00	1.00	0.00	1.00
Final Sat.:	1750	3800	1750	1750	3800	0	0	0	0	1750	0	1750

Capacity Analysis Module:

Vol/Sat:	0.02	0.18	0.22	0.21	0.25	0.00	0.00	0.00	0.00	0.03	0.00	0.03
Crit Moves:	****			****			****			****		
Green Time:	20.3	47.0	47.0	46.0	72.7	0.0	0.0	0.0	0.0	7.0	0.0	10.0
Volume/Cap:	0.11	0.39	0.47	0.47	0.35	0.00	0.00	0.00	0.00	0.38	0.00	0.35
Uniform Del:	32.5	17.2	18.0	18.6	5.0	0.0	0.0	0.0	0.0	44.4	0.0	42.0
IncrementDel:	0.1	0.1	0.4	0.4	0.1	0.0	0.0	0.0	0.0	2.0	0.0	1.2
InitQueueDel:	0.0	0.0	0.0	0.0	0.0	0.0	0.0	0.0	0.0	0.0	0.0	0.0
Delay Adj:	1.00	1.00	1.00	1.00	1.00	0.00	0.00	0.00	0.00	1.00	0.00	1.00
Delay/Veh:	32.7	17.4	18.4	19.0	5.0	0.0	0.0	0.0	0.0	46.4	0.0	43.2
User DelAdj:	1.00	1.00	1.00	1.00	1.00	1.00	1.00	1.00	1.00	1.00	1.00	1.00
AdjDel/Veh:	32.7	17.4	18.4	19.0	5.0	0.0	0.0	0.0	0.0	46.4	0.0	43.2
LOS by Move:	C-	B	B-	B-	A	A	A	A	A	D	A	D
HCM2kAvgQ:	1	7	9	8	5	0	0	0	0	2	0	2

\*\*\*\*\*  
 Note: Queue reported is the number of cars per lane.  
 \*\*\*\*\*

Level Of Service Computation Report  
 2000 HCM Operations Method (Future Volume Alternative)

\*\*\*\*\*  
 Intersection #8 Delta Road/San Felipe Road  
 \*\*\*\*\*

Cycle (sec): 100 Critical Vol./Cap.(X): 0.482  
 Loss Time (sec): 0 Average Delay (sec/veh): 19.1  
 Optimal Cycle: 44 Level Of Service: B-  
 \*\*\*\*\*

Street Name:	San Felipe Road						Delta Road													
Approach:	North Bound			South Bound			East Bound			West Bound										
Movement:	L	T	R	L	T	R	L	T	R	L	T	R								
Control:	Protected			Protected			Protected			Protected										
Rights:	Include			Include			Include			Include										
Min. Green:	7	10	10	7	10	10	7	10	10	7	10	10								
Y+R:	4.0	4.0	4.0	4.0	4.0	4.0	4.0	4.0	4.0	4.0	4.0	4.0								
Lanes:	1	0	2	0	1	1	0	2	0	0	0	0	0	0	0	1	0	0	0	1

Volume Module:

Base Vol:	0	577	145	61	992	0	0	0	0	350	0	208
Growth Adj:	1.00	1.00	1.00	1.00	1.00	1.00	1.00	1.00	1.00	1.00	1.00	1.00
Initial Bse:	0	577	145	61	992	0	0	0	0	350	0	208
Added Vol:	0	20	0	0	81	0	0	0	0	0	0	0
PasserByVol:	0	0	0	0	0	0	0	0	0	0	0	0
Initial Fut:	0	597	145	61	1073	0	0	0	0	350	0	208
User Adj:	1.00	1.00	1.00	1.00	1.00	1.00	1.00	1.00	1.00	1.00	1.00	1.00
PHF Adj:	1.00	1.00	1.00	1.00	1.00	1.00	1.00	1.00	1.00	1.00	1.00	1.00
PHF Volume:	0	597	145	61	1073	0	0	0	0	350	0	208
Reduct Vol:	0	0	0	0	0	0	0	0	0	0	0	0
Reduced Vol:	0	597	145	61	1073	0	0	0	0	350	0	208
PCE Adj:	1.00	1.00	1.00	1.00	1.00	1.00	1.00	1.00	1.00	1.00	1.00	1.00
MLF Adj:	1.00	1.00	1.00	1.00	1.00	1.00	1.00	1.00	1.00	1.00	1.00	1.00
FinalVolume:	0	597	145	61	1073	0	0	0	0	350	0	208

Saturation Flow Module:

Sat/Lane:	1900	1900	1900	1900	1900	1900	1900	1900	1900	1900	1900	1900
Adjustment:	0.92	1.00	0.92	0.92	1.00	0.92	0.92	1.00	0.92	0.92	1.00	0.92
Lanes:	1.00	2.00	1.00	1.00	2.00	0.00	0.00	0.00	0.00	1.00	0.00	1.00
Final Sat.:	1750	3800	1750	1750	3800	0	0	0	0	1750	0	1750

Capacity Analysis Module:

Vol/Sat:	0.00	0.16	0.08	0.03	0.28	0.00	0.00	0.00	0.00	0.20	0.00	0.12
Crit Moves:	****			****			****			****		
Green Time:	0.0	42.5	42.5	18.9	54.4	0.0	0.0	0.0	0.0	38.6	0.0	30.6
Volume/Cap:	0.00	0.37	0.19	0.18	0.52	0.00	0.00	0.00	0.00	0.52	0.00	0.39
Uniform Del:	0.0	19.6	18.0	34.0	14.5	0.0	0.0	0.0	0.0	23.6	0.0	27.4
IncrementDel:	0.0	0.1	0.1	0.3	0.2	0.0	0.0	0.0	0.0	0.7	0.0	0.5
InitQueueDel:	0.0	0.0	0.0	0.0	0.0	0.0	0.0	0.0	0.0	0.0	0.0	0.0
Delay Adj:	0.00	1.00	1.00	1.00	1.00	0.00	0.00	0.00	0.00	1.00	0.00	1.00
Delay/Veh:	0.0	19.8	18.2	34.3	14.7	0.0	0.0	0.0	0.0	24.3	0.0	27.8
User DelAdj:	1.00	1.00	1.00	1.00	1.00	1.00	1.00	1.00	1.00	1.00	1.00	1.00
AdjDel/Veh:	0.0	19.8	18.2	34.3	14.7	0.0	0.0	0.0	0.0	24.3	0.0	27.8
LOS by Move:	A	B-	B-	C-	B	A	A	A	A	C	A	C
HCM2kAvgQ:	0	6	3	2	10	0	0	0	0	9	0	6

\*\*\*\*\*  
 Note: Queue reported is the number of cars per lane.  
 \*\*\*\*\*

Level of Service Computation Report  
 2000 HCM Operations Method (Future Volume Alternative)

\*\*\*\*\*  
 Intersection #9 Fowler Road/San Felipe Road  
 \*\*\*\*\*

Cycle (sec): 100 Critical Vol./Cap.(X): 0.380  
 Loss Time (sec): 0 Average Delay (sec/veh): 14.7  
 Optimal Cycle: 37 Level of Service: B  
 \*\*\*\*\*

Street Name:	San Felipe Road						Fowler Road					
Approach:	North Bound			South Bound			East Bound			West Bound		
Movement:	L	T	R	L	T	R	L	T	R	L	T	R
Control:	Protected			Protected			Protected			Protected		
Rights:	Include			Include			Include			Include		
Min. Green:	7	10	10	7	10	10	7	10	10	7	10	10
Y+R:	4.0	4.0	4.0	4.0	4.0	4.0	4.0	4.0	4.0	4.0	4.0	4.0
Lanes:	1	0	2	0	1	1	0	0	0	0	0	1

Volume Module:

Base Vol:	10	679	90	124	936	0	0	0	0	88	0	187
Growth Adj:	1.00	1.00	1.00	1.00	1.00	1.00	1.00	1.00	1.00	1.00	1.00	1.00
Initial Bse:	10	679	90	124	936	0	0	0	0	88	0	187
Added Vol:	0	20	0	0	81	0	0	0	0	0	0	0
PasserByVol:	0	0	0	0	0	0	0	0	0	0	0	0
Initial Fut:	10	699	90	124	1017	0	0	0	0	88	0	187
User Adj:	1.00	1.00	1.00	1.00	1.00	1.00	1.00	1.00	1.00	1.00	1.00	1.00
PHF Adj:	1.00	1.00	1.00	1.00	1.00	1.00	1.00	1.00	1.00	1.00	1.00	1.00
PHF Volume:	10	699	90	124	1017	0	0	0	0	88	0	187
Reduct Vol:	0	0	0	0	0	0	0	0	0	0	0	0
Reduced Vol:	10	699	90	124	1017	0	0	0	0	88	0	187
PCE Adj:	1.00	1.00	1.00	1.00	1.00	1.00	1.00	1.00	1.00	1.00	1.00	1.00
MLF Adj:	1.00	1.00	1.00	1.00	1.00	1.00	1.00	1.00	1.00	1.00	1.00	1.00
FinalVolume:	10	699	90	124	1017	0	0	0	0	88	0	187

Saturation Flow Module:

Sat/Lane:	1900	1900	1900	1900	1900	1900	1900	1900	1900	1900	1900	1900
Adjustment:	0.92	1.00	0.92	0.92	1.00	0.92	0.92	1.00	0.92	0.92	1.00	0.92
Lanes:	1.00	2.00	1.00	1.00	2.00	0.00	0.00	0.00	0.00	1.00	0.00	1.00
Final Sat.:	1750	3800	1750	1750	3800	0	0	0	0	1750	0	1750

Capacity Analysis Module:

Vol/Sat:	0.01	0.18	0.05	0.07	0.27	0.00	0.00	0.00	0.00	0.05	0.00	0.11
Crit Moves:	****			****						****		
Green Time:	7.0	53.0	53.0	20.4	66.5	0.0	0.0	0.0	0.0	13.8	0.0	26.5
Volume/Cap:	0.08	0.35	0.10	0.35	0.40	0.00	0.00	0.00	0.00	0.36	0.00	0.40
Uniform Del:	43.5	13.5	11.6	34.1	7.7	0.0	0.0	0.0	0.0	39.1	0.0	30.2
IncrementDel:	0.3	0.1	0.0	0.6	0.1	0.0	0.0	0.0	0.0	0.9	0.0	0.6
InitQueueDel:	0.0	0.0	0.0	0.0	0.0	0.0	0.0	0.0	0.0	0.0	0.0	0.0
Delay Adj:	1.00	1.00	1.00	1.00	1.00	0.00	0.00	0.00	0.00	1.00	0.00	1.00
Delay/Veh:	43.8	13.6	11.7	34.7	7.8	0.0	0.0	0.0	0.0	40.0	0.0	30.8
User DelAdj:	1.00	1.00	1.00	1.00	1.00	1.00	1.00	1.00	1.00	1.00	1.00	1.00
AdjDel/Veh:	43.8	13.6	11.7	34.7	7.8	0.0	0.0	0.0	0.0	40.0	0.0	30.8
LOS by Move:	D	B	B+	C-	A	A	A	A	A	D	A	C
HCM2kAvgQ:	0	6	1	3	7	0	0	0	0	3	0	5

\*\*\*\*\*  
 Note: Queue reported is the number of cars per lane.  
 \*\*\*\*\*

Level of Service Computation Report  
 2000 HCM Operations Method (Future Volume Alternative)

\*\*\*\*\*  
 Intersection #10 San Felipe Road/Yerba Buena Avenue  
 \*\*\*\*\*

Cycle (sec): 100 Critical Vol./Cap.(X): 0.584  
 Loss Time (sec): 0 Average Delay (sec/veh): 20.3  
 Optimal Cycle: 55 Level of Service: C+

Street Name:	San Felipe Road						Yerba Buena Avenue					
Approach:	North Bound			South Bound			East Bound			West Bound		
Movement:	L	T	R	L	T	R	L	T	R	L	T	R
Control:	Protected			Protected			Protected			Protected		
Rights:	Include			Include			Include			Include		
Min. Green:	7	10	10	7	10	10	7	10	10	7	10	10
Y+R:	4.0	4.0	4.0	4.0	4.0	4.0	4.0	4.0	4.0	4.0	4.0	4.0
Lanes:	1	0	2	0	0	1	1	0	0	0	0	1

Volume Module:

Base Vol:	123	776	0	0	852	184	243	0	127	0	0	0
Growth Adj:	1.00	1.00	1.00	1.00	1.00	1.00	1.00	1.00	1.00	1.00	1.00	1.00
Initial Bse:	123	776	0	0	852	184	243	0	127	0	0	0
Added Vol:	0	20	0	0	81	0	0	0	0	0	0	0
PasserByVol:	0	0	0	0	0	0	0	0	0	0	0	0
Initial Fut:	123	796	0	0	933	184	243	0	127	0	0	0
User Adj:	1.00	1.00	1.00	1.00	1.00	1.00	1.00	1.00	1.00	1.00	1.00	1.00
PHF Adj:	1.00	1.00	1.00	1.00	1.00	1.00	1.00	1.00	1.00	1.00	1.00	1.00
PHF Volume:	123	796	0	0	933	184	243	0	127	0	0	0
Reduct Vol:	0	0	0	0	0	0	0	0	0	0	0	0
Reduced Vol:	123	796	0	0	933	184	243	0	127	0	0	0
PCE Adj:	1.00	1.00	1.00	1.00	1.00	1.00	1.00	1.00	1.00	1.00	1.00	1.00
MLF Adj:	1.00	1.00	1.00	1.00	1.00	1.00	1.00	1.00	1.00	1.00	1.00	1.00
FinalVolume:	123	796	0	0	933	184	243	0	127	0	0	0

Saturation Flow Module:

Sat/Lane:	1900	1900	1900	1900	1900	1900	1900	1900	1900	1900	1900	1900
Adjustment:	0.92	1.00	0.92	0.92	0.98	0.95	0.92	0.92	0.92	0.92	1.00	0.92
Lanes:	1.00	2.00	0.00	0.00	1.66	0.34	0.66	0.00	0.34	0.00	0.00	0.00
Final Sat.:	1750	3800	0	0	3090	609	1149	0	601	0	0	0

Capacity Analysis Module:

Vol/Sat:	0.07	0.21	0.00	0.00	0.30	0.30	0.21	0.00	0.21	0.00	0.00	0.00
Crit Moves:	****			****			****					
Green Time:	12.0	47.8	0.0	0.0	51.7	51.7	36.2	0.0	34.7	0.0	0.0	0.0
Volume/Cap:	0.58	0.44	0.00	0.00	0.58	0.58	0.58	0.00	0.61	0.00	0.00	0.00
Uniform Del:	41.6	17.2	0.0	0.0	16.7	16.7	25.8	0.0	27.0	0.0	0.0	0.0
IncrementDel:	4.1	0.2	0.0	0.0	0.5	0.5	1.4	0.0	1.8	0.0	0.0	0.0
InitQueueDel:	0.0	0.0	0.0	0.0	0.0	0.0	0.0	0.0	0.0	0.0	0.0	0.0
Delay Adj:	1.00	1.00	0.00	0.00	1.00	1.00	1.00	0.00	1.00	0.00	0.00	0.00
Delay/Veh:	45.8	17.4	0.0	0.0	17.2	17.2	27.2	0.0	28.8	0.0	0.0	0.0
User DelAdj:	1.00	1.00	1.00	1.00	1.00	1.00	1.00	1.00	1.00	1.00	1.00	1.00
AdjDel/Veh:	45.8	17.4	0.0	0.0	17.2	17.2	27.2	0.0	28.8	0.0	0.0	0.0
LOS by Move:	D	B	A	A	B	B	C	A	C	A	A	A
HCM2kAvgQ:	4	8	0	0	12	12	10	0	11	0	0	0

\*\*\*\*\*  
 Note: Queue reported is the number of cars per lane.  
 \*\*\*\*\*



## Level of Service Computation Report

2000 HCM Operations Method (Future Volume Alternative)

\*\*\*\*\*  
Intersection #11 Aborn Road/White Road/San Felipe Road  
\*\*\*\*\*

Cycle (sec): 155 Critical Vol./Cap.(X): 0.777  
 Loss Time (sec): 0 Average Delay (sec/veh): 48.7  
 Optimal Cycle: 102 Level of Service: D  
 \*\*\*\*\*

Street Name:	San Felipe Road						Aborn Road								
Approach:	North Bound			South Bound			East Bound			West Bound					
Movement:	L	T	R	L	T	R	L	T	R	L	T	R			
Control:	Protected			Protected			Protected			Protected					
Rights:	Include			Include			Include			Include					
Min. Green:	7	10	10	7	10	10	7	10	10	7	10	10			
Y+R:	4.0	4.0	4.0	4.0	4.0	4.0	4.0	4.0	4.0	4.0	4.0	4.0			
Lanes:	2	0	2	0	1	2	0	2	0	1	2	0	3	0	1

## Volume Module:

Base Vol:	410	501	88	80	503	518	365	441	412	141	990	177
Growth Adj:	1.00	1.00	1.00	1.00	1.00	1.00	1.00	1.00	1.00	1.00	1.00	1.00
Initial Bse:	410	501	88	80	503	518	365	441	412	141	990	177
Added Vol:	10	6	4	0	25	0	0	0	40	15	0	0
PasserByVol:	0	0	0	0	0	0	0	0	0	0	0	0
Initial Fut:	420	507	92	80	528	518	365	441	452	156	990	177
User Adj:	1.00	1.00	1.00	1.00	1.00	1.00	1.00	1.00	1.00	1.00	1.00	1.00
PHF Adj:	1.00	1.00	1.00	1.00	1.00	1.00	1.00	1.00	1.00	1.00	1.00	1.00
PHF Volume:	420	507	92	80	528	518	365	441	452	156	990	177
Reduct Vol:	0	0	0	0	0	0	0	0	0	0	0	0
Reduced Vol:	420	507	92	80	528	518	365	441	452	156	990	177
PCE Adj:	1.00	1.00	1.00	1.00	1.00	1.00	1.00	1.00	1.00	1.00	1.00	1.00
MLF Adj:	1.00	1.00	1.00	1.00	1.00	1.00	1.00	1.00	1.00	1.00	1.00	1.00
FinalVolume:	420	507	92	80	528	518	365	441	452	156	990	177

## Saturation Flow Module:

Sat/Lane:	1900	1900	1900	1900	1900	1900	1900	1900	1900	1900	1900	1900
Adjustment:	0.83	1.00	0.92	0.83	1.00	0.92	0.83	1.00	0.92	0.92	1.00	0.92
Lanes:	2.00	2.00	1.00	2.00	2.00	1.00	2.00	3.00	1.00	1.00	3.00	1.00
Final Sat.:	3150	3800	1750	3150	3800	1750	3150	5700	1750	1750	5700	1750

## Capacity Analysis Module:

Vol/Sat:	0.13	0.13	0.05	0.03	0.14	0.30	0.12	0.08	0.26	0.09	0.17	0.10
Crit Moves:	****			****			****		****	****		
Green Time:	26.6	64.0	64.0	21.7	59.1	59.1	27.7	51.5	51.5	17.8	41.6	41.6
Volume/Cap:	0.78	0.32	0.13	0.18	0.36	0.78	0.65	0.23	0.78	0.78	0.65	0.38
Uniform Del:	61.4	30.8	28.2	58.8	34.5	42.2	59.1	37.4	46.6	66.7	50.2	46.2
IncrementDel:	7.0	0.1	0.1	0.2	0.2	5.8	2.6	0.1	6.5	17.2	1.0	0.5
InitQueueDel:	0.0	0.0	0.0	0.0	0.0	0.0	0.0	0.0	0.0	0.0	0.0	0.0
Delay Adj:	1.00	1.00	1.00	1.00	1.00	1.00	1.00	1.00	1.00	1.00	1.00	1.00
Delay/Veh:	68.4	30.9	28.3	59.0	34.6	47.9	61.7	37.5	53.1	83.9	51.2	46.7
User DelAdj:	1.00	1.00	1.00	1.00	1.00	1.00	1.00	1.00	1.00	1.00	1.00	1.00
AdjDel/Veh:	68.4	30.9	28.3	59.0	34.6	47.9	61.7	37.5	53.1	83.9	51.2	46.7
LOS by Move:	E	C	C	E+	C-	D	E	D+	D-	F	D-	D
HCM2kAvgQ:	12	8	3	2	9	24	10	5	21	10	14	7

\*\*\*\*\*  
 Note: Queue reported is the number of cars per lane.  
 \*\*\*\*\*

## Level of Service Computation Report

## 2000 HCM Operations Method (Future Volume Alternative)

\*\*\*\*\*  
Intersection #12 Aborn Road/Nieman Boulevard  
\*\*\*\*\*

Cycle (sec): 170 Critical Vol./Cap.(X): 0.492  
 Loss Time (sec): 0 Average Delay (sec/veh): 40.6  
 Optimal Cycle: 45 Level of Service: D  
 \*\*\*\*\*

Street Name:	Nieman Boulevard						Aborn Road													
Approach:	North Bound			South Bound			East Bound			West Bound										
Movement:	L	T	R	L	T	R	L	T	R	L	T	R								
Control:	Protected			Protected			Protected			Protected										
Rights:	Include			Include			Include			Include										
Min. Green:	7	10	10	7	10	10	7	10	10	7	10	10								
Y+R:	4.0	4.0	4.0	4.0	4.0	4.0	4.0	4.0	4.0	4.0	4.0	4.0								
Lanes:	1	0	2	0	1	1	0	2	0	1	1	0	2	1	0	1	0	3	0	1

## Volume Module:

Base Vol:	128	266	152	209	128	130	20	921	48	164	1452	434
Growth Adj:	1.00	1.00	1.00	1.00	1.00	1.00	1.00	1.00	1.00	1.00	1.00	1.00
Initial Bse:	128	266	152	209	128	130	20	921	48	164	1452	434
Added Vol:	0	3	0	34	11	0	0	6	0	0	2	9
PasserByVol:	0	0	0	0	0	0	0	0	0	0	0	0
Initial Fut:	128	269	152	243	139	130	20	927	48	164	1454	443
User Adj:	1.00	1.00	1.00	1.00	1.00	1.00	1.00	1.00	1.00	1.00	1.00	1.00
PHF Adj:	1.00	1.00	1.00	1.00	1.00	1.00	1.00	1.00	1.00	1.00	1.00	1.00
PHF Volume:	128	269	152	243	139	130	20	927	48	164	1454	443
Reduct Vol:	0	0	0	0	0	0	0	0	0	0	0	0
Reduced Vol:	128	269	152	243	139	130	20	927	48	164	1454	443
PCE Adj:	1.00	1.00	1.00	1.00	1.00	1.00	1.00	1.00	1.00	1.00	1.00	1.00
MLF Adj:	1.00	1.00	1.00	1.00	1.00	1.00	1.00	1.00	1.00	1.00	1.00	1.00
FinalVolume:	128	269	152	243	139	130	20	927	48	164	1454	443

## Saturation Flow Module:

Sat/Lane:	1900	1900	1900	1900	1900	1900	1900	1900	1900	1900	1900	1900
Adjustment:	0.92	1.00	0.92	0.92	1.00	0.92	0.92	0.98	0.95	0.92	1.00	0.92
Lanes:	1.00	2.00	1.00	1.00	2.00	1.00	1.00	2.85	0.15	1.00	3.00	1.00
Final Sat.:	1750	3800	1750	1750	3800	1750	1750	5324	276	1750	5700	1750

## Capacity Analysis Module:

Vol/Sat:	0.07	0.07	0.09	0.14	0.04	0.07	0.01	0.17	0.17	0.09	0.26	0.25
Crit Moves:	****			****			****			****		
Green Time:	38.0	29.4	29.4	47.1	38.6	38.6	7.0	60.8	60.8	32.7	86.5	86.5
Volume/Cap:	0.33	0.41	0.50	0.50	0.16	0.33	0.28	0.49	0.49	0.49	0.50	0.50
Uniform Del:	55.3	62.5	63.6	51.6	52.7	54.9	79.0	42.5	42.5	61.2	27.5	27.5
IncrementDel:	0.5	0.4	1.3	0.8	0.1	0.5	2.1	0.2	0.2	1.1	0.1	0.4
InitQueueDel:	0.0	0.0	0.0	0.0	0.0	0.0	0.0	0.0	0.0	0.0	0.0	0.0
Delay Adj:	1.00	1.00	1.00	1.00	1.00	1.00	1.00	1.00	1.00	1.00	1.00	1.00
Delay/Veh:	55.8	62.9	65.0	52.4	52.8	55.4	81.1	42.7	42.7	62.3	27.7	27.9
User DelAdj:	1.00	1.00	1.00	1.00	1.00	1.00	1.00	1.00	1.00	1.00	1.00	1.00
AdjDel/Veh:	55.8	62.9	65.0	52.4	52.8	55.4	81.1	42.7	42.7	62.3	27.7	27.9
LOS by Move:	E+	E	E	D-	D-	E+	F	D	D	E	C	C
HCM2kAvgQ:	6	6	8	11	3	6	1	13	13	8	16	16

\*\*\*\*\*  
 Note: Queue reported is the number of cars per lane.  
 \*\*\*\*\*

## Level of Service Computation Report

2000 HCM Operations Method (Future Volume Alternative)

\*\*\*\*\*  
Intersection #13 Capitol Expressway/Aborn Road  
\*\*\*\*\*

Cycle (sec): 190 Critical Vol./Cap.(X): 0.895  
 Loss Time (sec): 0 Average Delay (sec/veh): 54.6  
 Optimal Cycle: 180 Level of Service: D-  
 \*\*\*\*\*

Street Name:	Capitol Expresswa						Aborn Road									
Approach:	North Bound			South Bound			East Bound			West Bound						
Movement:	L	T	R	L	T	R	L	T	R	L	T	R				
Control:	Protected			Protected			Protected			Protected						
Rights:	Include			Include			Include			Include						
Min. Green:	7	10	10	7	10	10	7	10	10	7	10	10				
Y+R:	4.0	4.0	4.0	4.0	4.0	4.0	4.0	4.0	4.0	4.0	4.0	4.0				
Lanes:	1	0	4	0	1	2	0	3	1	0	1	2	0	2	0	1

Volume Module:  
 Base Vol: 181 1545 686 255 1127 30 111 167 129 1097 643 169  
 Growth Adj: 1.00 1.00 1.00 1.00 1.00 1.00 1.00 1.00 1.00 1.00 1.00 1.00  
 Initial Bse: 181 1545 686 255 1127 30 111 167 129 1097 643 169  
 Added Vol: 0 0 0 0 0 0 0 6 0 0 2 0  
 PasserByVol: 0 0 0 0 0 0 0 0 0 0 0 0  
 Initial Fut: 181 1545 686 255 1127 30 111 173 129 1097 645 169  
 User Adj: 1.00 1.00 1.00 1.00 1.00 1.00 1.00 1.00 1.00 1.00 1.00 1.00  
 PHF Adj: 1.00 1.00 1.00 1.00 1.00 1.00 1.00 1.00 1.00 1.00 1.00 1.00  
 PHF Volume: 181 1545 686 255 1127 30 111 173 129 1097 645 169  
 Reduct Vol: 0 0 0 0 0 0 0 0 0 0 0 0  
 Reduced Vol: 181 1545 686 255 1127 30 111 173 129 1097 645 169  
 PCE Adj: 1.00 1.00 1.00 1.00 1.00 1.00 1.00 1.00 1.00 1.00 1.00 1.00  
 MLF Adj: 1.00 1.00 1.00 1.00 1.00 1.00 1.00 1.00 1.00 1.00 1.00 1.00  
 FinalVolume: 181 1545 686 255 1127 30 111 173 129 1097 645 169  
 -----

Saturation Flow Module:  
 Sat/Lane: 1900 1900 1900 1900 1900 1900 1900 1900 1900 1900 1900 1900  
 Adjustment: 0.92 1.00 0.92 0.83 0.99 0.95 0.92 1.00 0.92 0.83 1.00 0.92  
 Lanes: 1.00 4.00 1.00 2.00 3.89 0.11 1.00 2.00 1.00 2.00 2.00 1.00  
 Final Sat.: 1750 7600 1750 3150 7305 194 1750 3800 1750 3150 3800 1750  
 -----

Capacity Analysis Module:  
 Vol/Sat: 0.10 0.20 0.39 0.08 0.15 0.15 0.06 0.05 0.07 0.35 0.17 0.10  
 Crit Moves: \*\*\*\* \*  
 Green Time: 40.3 83.2 83.2 17.2 60.1 60.1 24.4 15.7 15.7 73.9 65.2 65.2  
 Volume/Cap: 0.49 0.46 0.89 0.89 0.49 0.49 0.49 0.55 0.89 0.89 0.49 0.28  
 Uniform Del: 62.3 35.7 46.7 81.0 49.7 49.7 73.0 79.4 81.8 51.5 46.8 43.0  
 IncremntDel: 1.0 0.1 13.0 28.1 0.2 0.2 1.7 2.1 45.2 8.8 0.3 0.3  
 InitQueueDel: 0.0 0.0 0.0 0.0 0.0 0.0 0.0 0.0 0.0 0.0 0.0 0.0  
 Delay Adj: 1.00 1.00 1.00 1.00 1.00 1.00 1.00 1.00 1.00 1.00 1.00 1.00  
 Delay/Veh: 63.3 35.8 59.8 109.1 49.9 49.9 74.7 81.5 127.0 60.3 47.1 43.2  
 User DelAdj: 1.00 1.00 1.00 1.00 1.00 1.00 1.00 1.00 1.00 1.00 1.00 1.00  
 AdjDel/Veh: 63.3 35.8 59.8 109.1 49.9 49.9 74.7 81.5 127.0 60.3 47.1 43.2  
 LOS by Move: E D+ E+ F D D E F F E D D  
 HCM2kAvgQ: 9 14 39 11 13 13 7 5 10 35 13 7

\*\*\*\*\*  
Note: Queue reported is the number of cars per lane.  
\*\*\*\*\*

Level of Service Computation Report  
 2000 HCM Operations Method (Future Volume Alternative)

\*\*\*\*\*  
 Intersection #14 Capitol Expressway/Silver Creek Road  
 \*\*\*\*\*

Cycle (sec): 190 Critical Vol./Cap.(X): 0.877  
 Loss Time (sec): 0 Average Delay (sec/veh): 54.6  
 Optimal Cycle: 180 Level of Service: D-  
 \*\*\*\*\*

Street Name:	Capitol Expresswa						Silver Creek Road					
Approach:	North Bound			South Bound			East Bound			West Bound		
Movement:	L	T	R	L	T	R	L	T	R	L	T	R
Control:	Protected			Protected			Protected			Protected		
Rights:	Include			Include			Include			Include		
Min. Green:	7	10	10	7	10	10	7	10	10	7	10	10
Y+R:	4.0	4.0	4.0	4.0	4.0	4.0	4.0	4.0	4.0	4.0	4.0	4.0
Lanes:	2	0	4	0	1	2	0	4	0	1	2	0

Volume Module:

Base Vol:	533	2025	308	119	2293	9	33	322	355	635	441	154
Growth Adj:	1.00	1.00	1.00	1.00	1.00	1.00	1.00	1.00	1.00	1.00	1.00	1.00
Initial Bse:	533	2025	308	119	2293	9	33	322	355	635	441	154
Added Vol:	0	0	20	0	0	0	0	6	0	5	2	0
PasserByVol:	0	0	0	0	0	0	0	0	0	0	0	0
Initial Fut:	533	2025	328	119	2293	9	33	328	355	640	443	154
User Adj:	1.00	1.00	1.00	1.00	1.00	1.00	1.00	1.00	1.00	1.00	1.00	1.00
PHF Adj:	1.00	1.00	1.00	1.00	1.00	1.00	1.00	1.00	1.00	1.00	1.00	1.00
PHF Volume:	533	2025	328	119	2293	9	33	328	355	640	443	154
Reduct Vol:	0	0	0	0	0	0	0	0	0	0	0	0
Reduced Vol:	533	2025	328	119	2293	9	33	328	355	640	443	154
PCE Adj:	1.00	1.00	1.00	1.00	1.00	1.00	1.00	1.00	1.00	1.00	1.00	1.00
MLF Adj:	1.00	1.00	1.00	1.00	1.00	1.00	1.00	1.00	1.00	1.00	1.00	1.00
FinalVolume:	533	2025	328	119	2293	9	33	328	355	640	443	154

Saturation Flow Module:

Sat/Lane:	1900	1900	1900	1900	1900	1900	1900	1900	1900	1900	1900	1900
Adjustment:	0.83	1.00	0.92	0.83	1.00	0.92	0.83	1.00	0.92	0.83	0.98	0.95
Lanes:	2.00	4.00	1.00	2.00	4.00	1.00	2.00	2.00	1.00	2.00	1.47	0.53
Final Sat.:	3150	7600	1750	3150	7600	1750	3150	3800	1750	3150	2745	954

Capacity Analysis Module:

Vol/Sat:	0.17	0.27	0.19	0.04	0.30	0.01	0.01	0.09	0.20	0.20	0.16	0.16
Crit Moves:	****			****			****		****	****		
Green Time:	36.7	89.0	89.0	13.0	65.4	65.4	17.1	44.0	44.0	44.0	70.9	70.9
Volume/Cap:	0.88	0.57	0.40	0.55	0.88	0.01	0.12	0.37	0.88	0.88	0.43	0.43
Uniform Del:	70.6	34.6	31.3	81.2	55.5	38.9	75.3	58.2	66.7	66.7	42.2	42.2
IncrementDel:	13.6	0.2	0.3	3.1	3.7	0.0	0.2	0.1	11.0	11.7	0.2	0.2
InitQueueDel:	0.0	0.0	0.0	0.0	0.0	0.0	0.0	0.0	0.0	0.0	0.0	0.0
Delay Adj:	1.00	1.00	1.00	1.00	1.00	1.00	1.00	1.00	1.00	1.00	1.00	1.00
Delay/Veh:	84.2	34.9	31.6	84.3	59.2	38.9	75.5	58.3	77.7	78.3	42.4	42.4
User DelAdj:	1.00	1.00	1.00	1.00	1.00	1.00	1.00	1.00	1.00	1.00	1.00	1.00
AdjDel/Veh:	84.2	34.9	31.6	84.3	59.2	38.9	75.5	58.3	77.7	78.3	42.4	42.4
LOS by Move:	F	C-	C	F	E+	D+	E-	E+	E-	E-	D	D
HCM2kAvgQ:	20	20	12	4	31	0	1	7	23	23	12	12

\*\*\*\*\*  
 Note: Queue reported is the number of cars per lane.  
 \*\*\*\*\*

-----  
 Scenario Report  
 Scenario: Existing Plus Project PM

Command: Default Command  
 Volume: Existing PM  
 Geometry: Existing  
 Impact Fee: Default Impact Fee  
 Trip Generation: Project PM  
 Trip Distribution: Project  
 Paths: Project  
 Routes: Default Route  
 Configuration: Default Configuration

-----  
 Impact Analysis Report  
 Level Of Service

Intersection		Base		Future		Change in
		Del/	V/	Del/	V/	
		LOS	Veh	LOS	Veh	
# 1 U.S. 101 SB Off-ramp/Yerba Bue		C	30.6 0.729	C	31.6 0.762	+ 1.008 D/V
# 2 U.S. 101 NB Off-ramp/Yerba Bue	B		16.6 0.419	B-	18.1 0.499	+ 1.432 D/V
# 3 Silver Creek Road/Yerba Buena	B-		18.4 0.417	B-	18.4 0.448	+ 0.047 D/V
# 4 Nieman Boulevard/Silver Creek	C		27.1 0.580	C	27.5 0.634	+ 0.422 D/V
# 5 Byington Drive/Yerba Buena Ave	A		8.1 0.422	A	8.0 0.458	-0.037 D/V
# 6 San Felipe Road/Yerba Buena Ro	D+		37.8 0.692	D	39.7 0.761	+ 1.912 D/V
# 7 Paseo de Arboles/San Felipe Ro	B		16.9 0.414	B-	19.0 0.468	+ 2.087 D/V
# 8 Delta Road/San Felipe Road	B		16.9 0.359	B	16.2 0.381	-0.740 D/V
# 9 Fowler Road/San Felipe Road	B+		10.5 0.329	B+	10.0 0.350	-0.499 D/V
# 10 San Felipe Road/Yerba Buena Av	B-		19.6 0.656	B-	19.6 0.690	+ 0.031 D/V
# 11 Aborn Road/White Road/San Feli	D		49.2 0.702	D	50.0 0.747	+ 0.879 D/V
# 12 Aborn Road/Nieman Boulevard	D		39.2 0.631	D	40.5 0.652	+ 1.322 D/V
# 13 Capitol Expressway/Aborn Road	E		67.2 1.049	E	67.4 1.051	+ 0.214 D/V
# 14 Capitol Expressway/Silver Cree	D-		52.0 0.830	D-	52.3 0.834	+ 0.312 D/V

Level Of Service Computation Report  
 2000 HCM Operations Method (Future Volume Alternative)

\*\*\*\*\*  
 Intersection #1 U.S. 101 SB Off-ramp/Yerba Buena Road  
 \*\*\*\*\*

Cycle (sec): 100 Critical Vol./Cap.(X): 0.762  
 Loss Time (sec): 0 Average Delay (sec/veh): 31.6  
 Optimal Cycle: 96 Level Of Service: C  
 \*\*\*\*\*

Street Name:	U.S. 101 SB Off-ramp						Yerba Buena Road					
Approach:	North Bound			South Bound			East Bound			West Bound		
Movement:	L	T	R	L	T	R	L	T	R	L	T	R
Control:	Protected			Protected			Protected			Protected		
Rights:	Include			Include			Include			Include		
Min. Green:	7	10	10	7	10	10	7	10	10	7	10	10
Y+R:	4.0	4.0	4.0	4.0	4.0	4.0	4.0	4.0	4.0	4.0	4.0	4.0
Lanes:	0	0	0	0	0	0	1	0	0	1	0	0

Volume Module:

Base Vol:	0	0	0	666	38	120	0	649	87	311	429	0
Growth Adj:	1.00	1.00	1.00	1.00	1.00	1.00	1.00	1.00	1.00	1.00	1.00	1.00
Initial Bse:	0	0	0	666	38	120	0	649	87	311	429	0
Added Vol:	0	0	0	43	0	0	0	5	0	13	3	0
PasserByVol:	0	0	0	0	0	0	0	0	0	0	0	0
Initial Fut:	0	0	0	709	38	120	0	654	87	324	432	0
User Adj:	1.00	1.00	1.00	1.00	1.00	1.00	1.00	1.00	1.00	1.00	1.00	1.00
PHF Adj:	1.00	1.00	1.00	1.00	1.00	1.00	1.00	1.00	1.00	1.00	1.00	1.00
PHF Volume:	0	0	0	709	38	120	0	654	87	324	432	0
Reduct Vol:	0	0	0	0	0	0	0	0	0	0	0	0
Reduced Vol:	0	0	0	709	38	120	0	654	87	324	432	0
PCE Adj:	1.00	1.00	1.00	1.00	1.00	1.00	1.00	1.00	1.00	1.00	1.00	1.00
MLF Adj:	1.00	1.00	1.00	1.00	1.00	1.00	1.00	1.00	1.00	1.00	1.00	1.00
FinalVolume:	0	0	0	709	38	120	0	654	87	324	432	0

Saturation Flow Module:

Sat/Lane:	1900	1900	1900	1900	1900	1900	1900	1900	1900	1900	1900	1900
Adjustment:	0.92	1.00	0.92	0.92	0.95	0.95	0.92	1.00	0.92	0.92	1.00	0.92
Lanes:	0.00	0.00	0.00	1.00	0.24	0.76	0.00	2.00	1.00	1.00	2.00	0.00
Final Sat.:	0	0	0	1750	433	1367	0	3800	1750	1750	3800	0

Capacity Analysis Module:

Vol/Sat:	0.00	0.00	0.00	0.41	0.09	0.09	0.00	0.17	0.05	0.19	0.11	0.00
Crit Moves:	****			****			****			****		
Green Time:	0.0	0.0	0.0	53.1	37.1	37.1	0.0	22.6	22.6	24.3	29.0	0.0
Volume/Cap:	0.00	0.00	0.00	0.76	0.24	0.24	0.00	0.76	0.22	0.76	0.39	0.00
Uniform Del:	0.0	0.0	0.0	18.5	21.7	21.7	0.0	36.2	31.5	35.2	28.4	0.0
IncrementDel:	0.0	0.0	0.0	3.8	0.2	0.2	0.0	4.1	0.3	7.9	0.2	0.0
InitQueueDel:	0.0	0.0	0.0	0.0	0.0	0.0	0.0	0.0	0.0	0.0	0.0	0.0
Delay Adj:	0.00	0.00	0.00	1.00	1.00	1.00	0.00	1.00	1.00	1.00	1.00	0.00
Delay/Veh:	0.0	0.0	0.0	22.2	21.8	21.8	0.0	40.3	31.8	43.1	28.7	0.0
User DelAdj:	1.00	1.00	1.00	1.00	1.00	1.00	1.00	1.00	1.00	1.00	1.00	1.00
AdjDel/Veh:	0.0	0.0	0.0	22.2	21.8	21.8	0.0	40.3	31.8	43.1	28.7	0.0
LOS by Move:	A	A	A	C+	C+	C+	A	D	C	D	C	A
HCM2kAvgQ:	0	0	0	20	4	4	0	11	2	10	5	0

\*\*\*\*\*  
 Note: Queue reported is the number of cars per lane.  
 \*\*\*\*\*

-----  
 Level of Service Computation Report  
 2000 HCM Operations Method (Future Volume Alternative)  
 \*\*\*\*\*  
 Intersection #2 U.S. 101 NB Off-ramp/Yerba Buena Road  
 \*\*\*\*\*  
 Cycle (sec): 100 Critical Vol./Cap.(X): 0.499  
 Loss Time (sec): 0 Average Delay (sec/veh): 18.1  
 Optimal Cycle: 45 Level of Service: B-  
 \*\*\*\*\*  
 Street Name: U.S. 101 NB Off-ram Yerba Buena Road  
 Approach: North Bound South Bound East Bound West Bound  
 Movement: L - T - R L - T - R L - T - R L - T - R  
 -----  
 Control: Protected Protected Protected Protected  
 Rights: Include Include Include Include  
 Min. Green: 7 10 10 7 10 10 7 10 10 7 10 10  
 Y+R: 4.0 4.0 4.0 4.0 4.0 4.0 4.0 4.0 4.0 4.0 4.0 4.0  
 Lanes: 0 0 0 1 0 1 0 1 0 0 1 0 1 1 0 1 0 2 0 1  
 -----  
 Volume Module:  
 Base Vol: 0 2 1 279 0 81 151 1180 0 1 632 513  
 Growth Adj: 1.00 1.00 1.00 1.00 1.00 1.00 1.00 1.00 1.00 1.00 1.00 1.00  
 Initial Bse: 0 2 1 279 0 81 151 1180 0 1 632 513  
 Added Vol: 0 0 0 0 25 0 0 0 48 0 0 16 22  
 PasserByVol: 0 0 0 0 0 0 0 0 0 0 0 0  
 Initial Fut: 0 2 1 304 0 81 151 1228 0 1 648 535  
 User Adj: 1.00 1.00 1.00 1.00 1.00 1.00 1.00 1.00 1.00 1.00 1.00 1.00  
 PHF Adj: 1.00 1.00 1.00 1.00 1.00 1.00 1.00 1.00 1.00 1.00 1.00 1.00  
 PHF Volume: 0 2 1 304 0 81 151 1228 0 1 648 535  
 Reduct Vol: 0 0 0 0 0 0 0 0 0 0 0 0  
 Reduced Vol: 0 2 1 304 0 81 151 1228 0 1 648 535  
 PCE Adj: 1.00 1.00 1.00 1.00 1.00 1.00 1.00 1.00 1.00 1.00 1.00 1.00  
 MLF Adj: 1.00 1.00 1.00 1.00 1.00 1.00 1.00 1.00 1.00 1.00 1.00 1.00  
 FinalVolume: 0 2 1 304 0 81 151 1228 0 1 648 535  
 -----  
 Saturation Flow Module:  
 Sat/Lane: 1900 1900 1900 1900 1900 1900 1900 1900 1900 1900 1900 1900  
 Adjustment: 0.92 0.95 0.95 0.92 1.00 0.92 0.92 0.97 0.92 0.92 1.00 0.92  
 Lanes: 0.00 0.67 0.33 1.65 0.00 0.35 1.00 2.00 0.00 1.00 2.00 1.00  
 Final Sat.: 0 1200 600 2892 0 608 1750 3700 0 1750 3800 1750  
 -----  
 Capacity Analysis Module:  
 Vol/Sat: 0.00 0.00 0.00 0.11 0.00 0.13 0.09 0.33 0.00 0.00 0.17 0.31  
 Crit Moves: \*\*\*\* \*\*\*\* \*\*\*\*  
 Green Time: 0.0 10.0 10.0 19.0 0.0 19.0 15.6 58.6 0.0 12.4 55.3 55.3  
 Volume/Cap: 0.00 0.02 0.02 0.55 0.00 0.70 0.55 0.57 0.00 0.00 0.31 0.55  
 Uniform Del: 0.0 40.6 40.6 36.6 0.0 37.8 39.0 12.8 0.0 38.4 12.0 14.4  
 IncremntDel: 0.0 0.0 0.0 1.0 0.0 4.0 2.4 0.4 0.0 0.0 0.1 0.7  
 InitQueueDel: 0.0 0.0 0.0 0.0 0.0 0.0 0.0 0.0 0.0 0.0 0.0 0.0  
 Delay Adj: 0.00 1.00 1.00 1.00 0.00 1.00 1.00 1.00 0.00 1.00 1.00 1.00  
 Delay/Veh: 0.0 40.6 40.6 37.6 0.0 41.8 41.4 13.2 0.0 38.4 12.1 15.1  
 User DelAdj: 1.00 1.00 1.00 1.00 1.00 1.00 1.00 1.00 1.00 1.00 1.00 1.00  
 AdjDel/Veh: 0.0 40.6 40.6 37.6 0.0 41.8 41.4 13.2 0.0 38.4 12.1 15.1  
 LOS by Move: A D D D+ A D D B A D+ B B  
 HCM2kAvgQ: 0 0 0 6 0 9 4 11 0 0 5 11  
 -----

-----  
 \*\*\*\*\*  
 Note: Queue reported is the number of cars per lane.  
 \*\*\*\*\*

## Level of Service Computation Report

## 2000 HCM Operations Method (Future Volume Alternative)

\*\*\*\*\*  
Intersection #3 Silver Creek Road/Yerba Buena Road  
\*\*\*\*\*

Cycle (sec): 100 Critical Vol./Cap.(X): 0.448  
 Loss Time (sec): 0 Average Delay (sec/veh): 18.4  
 Optimal Cycle: 41 Level of Service: B-  
 \*\*\*\*\*

Street Name:	Silver Creek Road						Yerba Buena Road					
Approach:	North Bound			South Bound			East Bound			West Bound		
Movement:	L	T	R	L	T	R	L	T	R	L	T	R
Control:	Protected			Protected			Protected			Protected		
Rights:	Include			Include			Include			Include		
Min. Green:	7	10	10	7	10	10	7	10	10	7	10	10
Y+R:	4.0	4.0	4.0	4.0	4.0	4.0	4.0	4.0	4.0	4.0	4.0	4.0
Lanes:	1	0	1	0	1	1	2	0	1	1	0	1

## Volume Module:

Base Vol:	26	21	13	251	41	197	188	1103	54	26	818	131
Growth Adj:	1.00	1.00	1.00	1.00	1.00	1.00	1.00	1.00	1.00	1.00	1.00	1.00
Initial Bse:	26	21	13	251	41	197	188	1103	54	26	818	131
Added Vol:	0	0	0	26	0	0	0	73	0	0	38	14
PasserByVol:	0	0	0	0	0	0	0	0	0	0	0	0
Initial Fut:	26	21	13	277	41	197	188	1176	54	26	856	145
User Adj:	1.00	1.00	1.00	1.00	1.00	1.00	1.00	1.00	1.00	1.00	1.00	1.00
PHF Adj:	1.00	1.00	1.00	1.00	1.00	1.00	1.00	1.00	1.00	1.00	1.00	1.00
PHF Volume:	26	21	13	277	41	197	188	1176	54	26	856	145
Reduct Vol:	0	0	0	0	0	0	0	0	0	0	0	0
Reduced Vol:	26	21	13	277	41	197	188	1176	54	26	856	145
PCE Adj:	1.00	1.00	1.00	1.00	1.00	1.00	1.00	1.00	1.00	1.00	1.00	1.00
MLF Adj:	1.00	1.00	1.00	1.00	1.00	1.00	1.00	1.00	1.00	1.00	1.00	1.00
FinalVolume:	26	21	13	277	41	197	188	1176	54	26	856	145

## Saturation Flow Module:

Sat/Lane:	1900	1900	1900	1900	1900	1900	1900	1900	1900	1900	1900	1900
Adjustment:	0.92	1.00	0.92	0.93	0.95	0.92	0.83	0.97	0.95	0.92	0.98	0.95
Lanes:	1.00	1.00	1.00	1.75	0.25	1.00	2.00	1.91	0.09	1.00	1.70	0.30
Final Sat.:	1750	1900	1750	3092	458	1750	3150	3537	162	1750	3164	536

## Capacity Analysis Module:

Vol/Sat:	0.01	0.01	0.01	0.09	0.09	0.11	0.06	0.33	0.33	0.01	0.27	0.27
Crit Moves:	****			****			****			****		
Green Time:	10.6	10.0	10.0	17.6	17.0	17.0	14.9	65.4	65.4	7.0	57.5	57.5
Volume/Cap:	0.14	0.11	0.07	0.51	0.53	0.66	0.40	0.51	0.51	0.21	0.47	0.47
Uniform Del:	40.6	41.0	40.8	37.3	37.8	38.8	38.5	9.0	9.0	43.9	12.4	12.4
IncrementDel:	0.3	0.3	0.2	0.7	0.9	5.4	0.6	0.2	0.2	0.9	0.2	0.2
InitQueueDel:	0.0	0.0	0.0	0.0	0.0	0.0	0.0	0.0	0.0	0.0	0.0	0.0
Delay Adj:	1.00	1.00	1.00	1.00	1.00	1.00	1.00	1.00	1.00	1.00	1.00	1.00
Delay/Veh:	40.9	41.2	41.0	38.0	38.7	44.2	39.1	9.2	9.2	44.8	12.5	12.5
User DelAdj:	1.00	1.00	1.00	1.00	1.00	1.00	1.00	1.00	1.00	1.00	1.00	1.00
AdjDel/Veh:	40.9	41.2	41.0	38.0	38.7	44.2	39.1	9.2	9.2	44.8	12.5	12.5
LOS by Move:	D	D	D	D+	D+	D	D	A	A	D	B	B
HCM2kAvgQ:	1	1	0	5	5	7	3	10	10	1	9	9

\*\*\*\*\*  
 Note: Queue reported is the number of cars per lane.  
 \*\*\*\*\*



Level Of Service Computation Report  
 2000 HCM Operations Method (Future Volume Alternative)

\*\*\*\*\*  
 Intersection #4 Nieman Boulevard/Silver Creek Valley Road/Yerba Buena Road  
 \*\*\*\*\*

Cycle (sec): 100 Critical Vol./Cap.(X): 0.634  
 Loss Time (sec): 0 Average Delay (sec/veh): 27.5  
 Optimal Cycle: 62 Level Of Service: C  
 \*\*\*\*\*

Street Name:	Nieman Boulevard						Yerba Buena Road								
Approach:	North Bound			South Bound			East Bound			West Bound					
Movement:	L	T	R	L	T	R	L	T	R	L	T	R			
Control:	Protected			Protected			Protected			Protected					
Rights:	Include			Include			Include			Include					
Min. Green:	7	10	10	7	10	10	7	10	10	7	10	10			
Y+R:	4.0	4.0	4.0	4.0	4.0	4.0	4.0	4.0	4.0	4.0	4.0	4.0			
Lanes:	1	0	2	0	1	1	0	2	0	1	1	0	2	0	1

Volume Module:

Base Vol:	156	137	315	104	170	30	21	841	214	209	675	83
Growth Adj:	1.00	1.00	1.00	1.00	1.00	1.00	1.00	1.00	1.00	1.00	1.00	1.00
Initial Bse:	156	137	315	104	170	30	21	841	214	209	675	83
Added Vol:	0	0	25	11	0	0	0	99	0	13	52	6
PasserByVol:	0	0	0	0	0	0	0	0	0	0	0	0
Initial Fut:	156	137	340	115	170	30	21	940	214	222	727	89
User Adj:	1.00	1.00	1.00	1.00	1.00	1.00	1.00	1.00	1.00	1.00	1.00	1.00
PHF Adj:	1.00	1.00	1.00	1.00	1.00	1.00	1.00	1.00	1.00	1.00	1.00	1.00
PHF Volume:	156	137	340	115	170	30	21	940	214	222	727	89
Reduct Vol:	0	0	0	0	0	0	0	0	0	0	0	0
Reduced Vol:	156	137	340	115	170	30	21	940	214	222	727	89
PCE Adj:	1.00	1.00	1.00	1.00	1.00	1.00	1.00	1.00	1.00	1.00	1.00	1.00
MLF Adj:	1.00	1.00	1.00	1.00	1.00	1.00	1.00	1.00	1.00	1.00	1.00	1.00
FinalVolume:	156	137	340	115	170	30	21	940	214	222	727	89

Saturation Flow Module:

Sat/Lane:	1900	1900	1900	1900	1900	1900	1900	1900	1900	1900	1900	1900
Adjustment:	0.92	1.00	0.92	0.92	1.00	0.92	0.92	1.00	0.92	0.92	1.00	0.92
Lanes:	1.00	2.00	1.00	1.00	2.00	1.00	1.00	2.00	1.00	1.00	2.00	1.00
Final Sat.:	1750	3800	1750	1750	3800	1750	1750	3800	1750	1750	3800	1750

Capacity Analysis Module:

Vol/Sat:	0.09	0.04	0.19	0.07	0.04	0.02	0.01	0.25	0.12	0.13	0.19	0.05
Crit Moves:	****			****			****			****		
Green Time:	19.3	30.6	30.6	10.4	21.7	21.7	15.8	39.0	39.0	20.0	43.2	43.2
Volume/Cap:	0.46	0.12	0.63	0.63	0.21	0.08	0.08	0.63	0.31	0.63	0.44	0.12
Uniform Del:	35.7	25.0	29.9	43.0	32.1	31.2	35.9	24.7	21.2	36.6	19.9	17.0
IncrementDel:	1.0	0.0	2.5	7.2	0.1	0.1	0.1	0.9	0.3	3.8	0.2	0.1
InitQueueDel:	0.0	0.0	0.0	0.0	0.0	0.0	0.0	0.0	0.0	0.0	0.0	0.0
Delay Adj:	1.00	1.00	1.00	1.00	1.00	1.00	1.00	1.00	1.00	1.00	1.00	1.00
Delay/Veh:	36.7	25.0	32.4	50.2	32.2	31.3	36.0	25.6	21.5	40.4	20.1	17.1
User DelAdj:	1.00	1.00	1.00	1.00	1.00	1.00	1.00	1.00	1.00	1.00	1.00	1.00
AdjDel/Veh:	36.7	25.0	32.4	50.2	32.2	31.3	36.0	25.6	21.5	40.4	20.1	17.1
LOS by Move:	D+	C	C-	D	C-	C	D+	C	C+	D	C+	B
HCM2kAvgQ:	5	2	10	5	2	1	1	11	5	7	8	2

\*\*\*\*\*  
 Note: Queue reported is the number of cars per lane.  
 \*\*\*\*\*

## Level of Service Computation Report

## 2000 HCM Operations Method (Future Volume Alternative)

\*\*\*\*\*  
 Intersection #5 Byington Drive/Yerba Buena Avenue/Yerba Buena Road  
 \*\*\*\*\*

Cycle (sec): 100 Critical Vol./Cap.(X): 0.458  
 Loss Time (sec): 0 Average Delay (sec/veh): 8.0  
 Optimal Cycle: 42 Level of Service: A  
 \*\*\*\*\*

Street Name:	Byington Drive						Yerba Buena Avenue					
	North Bound			South Bound			East Bound			West Bound		
Approach:	L	T	R	L	T	R	L	T	R	L	T	R
Movement:												
Control:	Protected			Protected			Protected			Protected		
Rights:	Include			Include			Include			Include		
Min. Green:	7	10	10	7	10	10	7	10	10	7	10	10
Y+R:	4.0	4.0	4.0	4.0	4.0	4.0	4.0	4.0	4.0	4.0	4.0	4.0
Lanes:	0	0	1	0	0	1	1	0	1	1	0	1

Volume Module:												
Base Vol:	2	1	17	15	1	39	53	1360	13	14	975	24
Growth Adj:	1.00	1.00	1.00	1.00	1.00	1.00	1.00	1.00	1.00	1.00	1.00	1.00
Initial Bse:	2	1	17	15	1	39	53	1360	13	14	975	24
Added Vol:	0	0	0	0	0	0	0	135	0	0	71	0
PasserByVol:	0	0	0	0	0	0	0	0	0	0	0	0
Initial Fut:	2	1	17	15	1	39	53	1495	13	14	1046	24
User Adj:	1.00	1.00	1.00	1.00	1.00	1.00	1.00	1.00	1.00	1.00	1.00	1.00
PHF Adj:	1.00	1.00	1.00	1.00	1.00	1.00	1.00	1.00	1.00	1.00	1.00	1.00
PHF Volume:	2	1	17	15	1	39	53	1495	13	14	1046	24
Reduct Vol:	0	0	0	0	0	0	0	0	0	0	0	0
Reduced Vol:	2	1	17	15	1	39	53	1495	13	14	1046	24
PCE Adj:	1.00	1.00	1.00	1.00	1.00	1.00	1.00	1.00	1.00	1.00	1.00	1.00
MLF Adj:	1.00	1.00	1.00	1.00	1.00	1.00	1.00	1.00	1.00	1.00	1.00	1.00
FinalVolume:	2	1	17	15	1	39	53	1495	13	14	1046	24

Saturation Flow Module:												
Sat/Lane:	1900	1900	1900	1900	1900	1900	1900	1900	1900	1900	1900	1900
Adjustment:	0.92	0.92	0.92	0.92	0.92	0.92	0.92	0.97	0.95	0.92	0.97	0.95
Lanes:	0.10	0.05	0.85	0.27	0.02	0.71	1.00	1.98	0.02	1.00	1.95	0.05
Final Sat.:	175	88	1488	477	32	1241	1750	3668	32	1750	3617	83

Capacity Analysis Module:												
Vol/Sat:	0.01	0.01	0.01	0.03	0.03	0.03	0.03	0.41	0.41	0.01	0.29	0.29
Crit Moves:	****			****			****			****		
Green Time:	7.0	10.0	10.0	7.0	10.0	10.0	16.2	76.0	76.0	7.0	66.8	66.8
Volume/Cap:	0.16	0.11	0.11	0.45	0.31	0.31	0.19	0.54	0.54	0.11	0.43	0.43
Uniform Del:	43.7	41.0	41.0	44.6	41.8	41.8	36.2	4.9	4.9	43.6	7.7	7.7
IncrementDel:	0.6	0.3	0.3	2.6	1.0	1.0	0.3	0.2	0.2	0.4	0.1	0.1
InitQueueDel:	0.0	0.0	0.0	0.0	0.0	0.0	0.0	0.0	0.0	0.0	0.0	0.0
Delay Adj:	1.00	1.00	1.00	1.00	1.00	1.00	1.00	1.00	1.00	1.00	1.00	1.00
Delay/Veh:	44.4	41.3	41.3	47.3	42.8	42.8	36.6	5.1	5.1	44.0	7.9	7.9
User DelAdj:	1.00	1.00	1.00	1.00	1.00	1.00	1.00	1.00	1.00	1.00	1.00	1.00
AdjDel/Veh:	44.4	41.3	41.3	47.3	42.8	42.8	36.6	5.1	5.1	44.0	7.9	7.9
LOS by Move:	D	D	D	D	D	D	D+	A	A	D	A	A
HCM2kAvgQ:	1	1	1	2	2	2	1	9	9	0	7	7

\*\*\*\*\*  
 Note: Queue reported is the number of cars per lane.  
 \*\*\*\*\*

## Level of Service Computation Report

## 2000 HCM Operations Method (Future Volume Alternative)

\*\*\*\*\*  
 Intersection #6 San Felipe Road/Yerba Buena Road  
 \*\*\*\*\*

Cycle (sec): 120 Critical Vol./Cap.(X): 0.761  
 Loss Time (sec): 0 Average Delay (sec/veh): 39.7  
 Optimal Cycle: 95 Level of Service: D  
 \*\*\*\*\*

Street Name:	San Felipe Road						Yerba Buena Road					
Approach:	North Bound			South Bound			East Bound			West Bound		
Movement:	L	T	R	L	T	R	L	T	R	L	T	R
Control:	Protected			Protected			Protected			Protected		
Rights:	Include			Include			Include			Include		
Min. Green:	7	10	10	7	10	10	7	10	10	7	10	10
Y+R:	4.0	4.0	4.0	4.0	4.0	4.0	4.0	4.0	4.0	4.0	4.0	4.0
Lanes:	2	0	2	0	1	1	1	0	2	0	1	1

Volume Module:	San Felipe Road			Yerba Buena Road			Yerba Buena Road			Yerba Buena Road		
Base Vol:	196	326	80	202	296	410	506	497	309	137	403	145
Growth Adj:	1.00	1.00	1.00	1.00	1.00	1.00	1.00	1.00	1.00	1.00	1.00	1.00
Initial Bse:	196	326	80	202	296	410	506	497	309	137	403	145
Added Vol:	0	13	13	43	7	36	68	68	0	7	36	26
PasserByVol:	0	0	0	0	0	0	0	0	0	0	0	0
Initial Fut:	196	339	93	245	303	446	574	565	309	144	439	171
User Adj:	1.00	1.00	1.00	1.00	1.00	1.00	1.00	1.00	1.00	1.00	1.00	1.00
PHF Adj:	1.00	1.00	1.00	1.00	1.00	1.00	1.00	1.00	1.00	1.00	1.00	1.00
PHF Volume:	196	339	93	245	303	446	574	565	309	144	439	171
Reduct Vol:	0	0	0	0	0	0	0	0	0	0	0	0
Reduced Vol:	196	339	93	245	303	446	574	565	309	144	439	171
PCE Adj:	1.00	1.00	1.00	1.00	1.00	1.00	1.00	1.00	1.00	1.00	1.00	1.00
MLF Adj:	1.00	1.00	1.00	1.00	1.00	1.00	1.00	1.00	1.00	1.00	1.00	1.00
FinalVolume:	196	339	93	245	303	446	574	565	309	144	439	171

Saturation Flow Module:	San Felipe Road			Yerba Buena Road			Yerba Buena Road			Yerba Buena Road		
Sat/Lane:	1900	1900	1900	1900	1900	1900	1900	1900	1900	1900	1900	1900
Adjustment:	0.83	1.00	0.92	0.92	1.00	0.92	0.92	1.00	0.92	0.92	1.00	0.92
Lanes:	2.00	2.00	1.00	1.00	2.00	1.00	1.00	2.00	1.00	1.00	2.00	1.00
Final Sat.:	3150	3800	1750	1750	3800	1750	1750	3800	1750	1750	3800	1750

Capacity Analysis Module:	San Felipe Road			Yerba Buena Road			Yerba Buena Road			Yerba Buena Road		
Vol/Sat:	0.06	0.09	0.05	0.14	0.08	0.25	0.33	0.15	0.18	0.08	0.12	0.10
Crit Moves:	****			****			****			****		
Green Time:	9.8	19.5	19.5	30.6	40.2	40.2	51.7	47.7	47.7	22.2	18.2	18.2
Volume/Cap:	0.76	0.55	0.33	0.55	0.24	0.76	0.76	0.37	0.44	0.44	0.76	0.64
Uniform Del:	53.9	46.2	44.5	38.8	28.8	35.6	28.9	25.6	26.4	43.4	48.8	47.8
IncrementDel:	12.4	1.1	0.7	1.5	0.1	5.8	4.5	0.2	0.5	1.0	5.9	5.3
InitQueueDel:	0.0	0.0	0.0	0.0	0.0	0.0	0.0	0.0	0.0	0.0	0.0	0.0
Delay Adj:	1.00	1.00	1.00	1.00	1.00	1.00	1.00	1.00	1.00	1.00	1.00	1.00
Delay/Veh:	66.4	47.3	45.2	40.2	28.9	41.4	33.4	25.7	26.9	44.4	54.7	53.1
User DelAdj:	1.00	1.00	1.00	1.00	1.00	1.00	1.00	1.00	1.00	1.00	1.00	1.00
AdjDel/Veh:	66.4	47.3	45.2	40.2	28.9	41.4	33.4	25.7	26.9	44.4	54.7	53.1
LOS by Move:	E	D	D	D	C	D	C-	C	C	D	D-	D-
HCM2kAvgQ:	6	6	3	9	4	17	19	7	9	5	9	7

\*\*\*\*\*  
 Note: Queue reported is the number of cars per lane.  
 \*\*\*\*\*

Level Of Service Computation Report  
 2000 HCM Operations Method (Future Volume Alternative)

\*\*\*\*\*  
 Intersection #7 Paseo de Arboles/San Felipe Road  
 \*\*\*\*\*

Cycle (sec): 100 Critical Vol./Cap.(X): 0.468  
 Loss Time (sec): 0 Average Delay (sec/veh): 19.0  
 Optimal Cycle: 43 Level Of Service: B-  
 \*\*\*\*\*

Street Name:	San Felipe Road						Paseo de Arboles					
Approach:	North Bound			South Bound			East Bound			West Bound		
Movement:	L	T	R	L	T	R	L	T	R	L	T	R
Control:	Protected			Protected			Protected			Protected		
Rights:	Include			Include			Include			Include		
Min. Green:	7	10	10	7	10	10	7	10	10	7	10	10
Y+R:	4.0	4.0	4.0	4.0	4.0	4.0	4.0	4.0	4.0	4.0	4.0	4.0
Lanes:	1	0	2	0	1	1	0	0	0	0	1	0

Volume Module:

Base Vol:	48	743	177	258	884	1	0	0	0	124	0	82
Growth Adj:	1.00	1.00	1.00	1.00	1.00	1.00	1.00	1.00	1.00	1.00	1.00	1.00
Initial Bse:	48	743	177	258	884	1	0	0	0	124	0	82
Added Vol:	0	21	85	40	40	0	0	0	0	45	0	21
PasserByVol:	0	0	0	0	0	0	0	0	0	0	0	0
Initial Fut:	48	764	262	298	924	1	0	0	0	169	0	103
User Adj:	1.00	1.00	1.00	1.00	1.00	1.00	1.00	1.00	1.00	1.00	1.00	1.00
PHF Adj:	1.00	1.00	1.00	1.00	1.00	1.00	1.00	1.00	1.00	1.00	1.00	1.00
PHF Volume:	48	764	262	298	924	1	0	0	0	169	0	103
Reduct Vol:	0	0	0	0	0	0	0	0	0	0	0	0
Reduced Vol:	48	764	262	298	924	1	0	0	0	169	0	103
PCE Adj:	1.00	1.00	1.00	1.00	1.00	1.00	1.00	1.00	1.00	1.00	1.00	1.00
MLF Adj:	1.00	1.00	1.00	1.00	1.00	1.00	1.00	1.00	1.00	1.00	1.00	1.00
FinalVolume:	48	764	262	298	924	1	0	0	0	169	0	103

Saturation Flow Module:

Sat/Lane:	1900	1900	1900	1900	1900	1900	1900	1900	1900	1900	1900	1900
Adjustment:	0.92	1.00	0.92	0.92	0.97	0.95	0.92	1.00	0.92	0.92	1.00	0.92
Lanes:	1.00	2.00	1.00	1.00	1.99	0.01	0.00	0.00	0.00	1.00	0.00	1.00
Final Sat.:	1750	3800	1750	1750	3696	4	0	0	0	1750	0	1750

Capacity Analysis Module:

Vol/Sat:	0.03	0.20	0.15	0.17	0.25	0.25	0.00	0.00	0.00	0.10	0.00	0.06
Crit Moves:	****			****			****			****		
Green Time:	17.4	43.0	43.0	36.4	62.0	62.0	0.0	0.0	0.0	20.6	0.0	18.0
Volume/Cap:	0.16	0.47	0.35	0.47	0.40	0.40	0.00	0.00	0.00	0.47	0.00	0.33
Uniform Del:	35.1	20.4	19.1	24.4	9.6	9.6	0.0	0.0	0.0	34.9	0.0	35.7
IncrementDel:	0.2	0.2	0.3	0.5	0.1	0.1	0.0	0.0	0.0	1.0	0.0	0.6
InitQueueDel:	0.0	0.0	0.0	0.0	0.0	0.0	0.0	0.0	0.0	0.0	0.0	0.0
Delay Adj:	1.00	1.00	1.00	1.00	1.00	1.00	0.00	0.00	0.00	1.00	0.00	1.00
Delay/Veh:	35.4	20.6	19.4	24.9	9.7	9.7	0.0	0.0	0.0	35.8	0.0	36.3
User DelAdj:	1.00	1.00	1.00	1.00	1.00	1.00	1.00	1.00	1.00	1.00	1.00	1.00
AdjDel/Veh:	35.4	20.6	19.4	24.9	9.7	9.7	0.0	0.0	0.0	35.8	0.0	36.3
LOS by Move:	D+	C+	B-	C	A	A	A	A	A	D+	A	D+
HCM2kAvgQ:	1	8	6	7	7	7	0	0	0	5	0	3

\*\*\*\*\*  
 Note: Queue reported is the number of cars per lane.  
 \*\*\*\*\*

## Level of Service Computation Report

2000 HCM Operations Method (Future Volume Alternative)

\*\*\*\*\*  
Intersection #8 Delta Road/San Felipe Road  
\*\*\*\*\*

Cycle (sec): 100 Critical Vol./Cap.(X): 0.381  
 Loss Time (sec): 0 Average Delay (sec/veh): 16.2  
 Optimal Cycle: 37 Level of Service: B  
 \*\*\*\*\*

Street Name:	San Felipe Road						Delta Road					
Approach:	North Bound			South Bound			East Bound			West Bound		
Movement:	L	T	R	L	T	R	L	T	R	L	T	R
Control:	Protected			Protected			Protected			Protected		
Rights:	Include			Include			Include			Include		
Min. Green:	7	10	10	7	10	10	7	10	10	7	10	10
Y+R:	4.0	4.0	4.0	4.0	4.0	4.0	4.0	4.0	4.0	4.0	4.0	4.0
Lanes:	1	0	2	0	1	1	0	0	0	0	1	0

Volume Module:	San Felipe Road			Delta Road			Delta Road			Delta Road		
Base Vol:	5	581	236	198	935	2	0	0	0	185	1	98
Growth Adj:	1.00	1.00	1.00	1.00	1.00	1.00	1.00	1.00	1.00	1.00	1.00	1.00
Initial Bse:	5	581	236	198	935	2	0	0	0	185	1	98
Added Vol:	0	42	0	0	80	0	0	0	0	0	0	0
PasserByVol:	0	0	0	0	0	0	0	0	0	0	0	0
Initial Fut:	5	623	236	198	1015	2	0	0	0	185	1	98
User Adj:	1.00	1.00	1.00	1.00	1.00	1.00	1.00	1.00	1.00	1.00	1.00	1.00
PHF Adj:	1.00	1.00	1.00	1.00	1.00	1.00	1.00	1.00	1.00	1.00	1.00	1.00
PHF Volume:	5	623	236	198	1015	2	0	0	0	185	1	98
Reduct Vol:	0	0	0	0	0	0	0	0	0	0	0	0
Reduced Vol:	5	623	236	198	1015	2	0	0	0	185	1	98
PCE Adj:	1.00	1.00	1.00	1.00	1.00	1.00	1.00	1.00	1.00	1.00	1.00	1.00
MLF Adj:	1.00	1.00	1.00	1.00	1.00	1.00	1.00	1.00	1.00	1.00	1.00	1.00
FinalVolume:	5	623	236	198	1015	2	0	0	0	185	1	98

Saturation Flow Module:	San Felipe Road			Delta Road			Delta Road			Delta Road		
Sat/Lane:	1900	1900	1900	1900	1900	1900	1900	1900	1900	1900	1900	1900
Adjustment:	0.92	1.00	0.92	0.92	0.97	0.95	0.92	1.00	0.92	0.95	0.95	0.95
Lanes:	1.00	2.00	1.00	1.00	1.99	0.01	0.00	0.00	0.00	1.00	0.01	0.99
Final Sat.:	1750	3800	1750	1750	3693	7	0	0	0	1800	18	1782

Capacity Analysis Module:	San Felipe Road			Delta Road			Delta Road			Delta Road		
Vol/Sat:	0.00	0.16	0.13	0.11	0.27	0.27	0.00	0.00	0.00	0.10	0.06	0.06
Crit Moves:	****			****			****			****		
Green Time:	7.0	44.2	44.2	30.5	67.7	67.7	0.0	0.0	0.0	25.3	20.8	20.8
Volume/Cap:	0.04	0.37	0.31	0.37	0.41	0.41	0.00	0.00	0.00	0.41	0.26	0.26
Uniform Del:	43.4	18.6	18.0	27.2	7.2	7.2	0.0	0.0	0.0	31.1	33.2	33.2
IncrementDel:	0.1	0.1	0.2	0.4	0.1	0.1	0.0	0.0	0.0	0.4	0.1	0.1
InitQueueDel:	0.0	0.0	0.0	0.0	0.0	0.0	0.0	0.0	0.0	0.0	0.0	0.0
Delay Adj:	1.00	1.00	1.00	1.00	1.00	1.00	0.00	0.00	0.00	1.00	1.00	1.00
Delay/Veh:	43.5	18.8	18.2	27.7	7.3	7.3	0.0	0.0	0.0	31.5	33.3	33.3
User DelAdj:	1.00	1.00	1.00	1.00	1.00	1.00	1.00	1.00	1.00	1.00	1.00	1.00
AdjDel/Veh:	43.5	18.8	18.2	27.7	7.3	7.3	0.0	0.0	0.0	31.5	33.3	33.3
LOS by Move:	D	B-	B-	C	A	A	A	A	A	C	C-	C-
HCM2kAvgQ:	0	6	5	5	7	7	0	0	0	5	3	3

\*\*\*\*\*  
Note: Queue reported is the number of cars per lane.  
\*\*\*\*\*

## Level Of Service Computation Report

2000 HCM Operations Method (Future Volume Alternative)

\*\*\*\*\*  
Intersection #9 Fowler Road/San Felipe Road  
\*\*\*\*\*

Cycle (sec): 100 Critical Vol./Cap.(X): 0.350  
 Loss Time (sec): 0 Average Delay (sec/veh): 10.0  
 Optimal Cycle: 35 Level Of Service: B+

Street Name:	San Felipe Road						Fowler Road					
	North Bound			South Bound			East Bound			West Bound		
Approach:	L - T - R			L - T - R			L - T - R			L - T - R		
Movement:	L	T	R	L	T	R	L	T	R	L	T	R
Control:	Protected			Protected			Protected			Protected		
Rights:	Include			Include			Include			Include		
Min. Green:	7	10	10	7	10	10	7	10	10	7	10	10
Y+R:	4.0	4.0	4.0	4.0	4.0	4.0	4.0	4.0	4.0	4.0	4.0	4.0
Lanes:	1	0	2	0	1	1	0	0	0	0	0	1

Volume Module:												
Base Vol:	15	612	73	145	1043	0	0	0	0	81	0	78
Growth Adj:	1.00	1.00	1.00	1.00	1.00	1.00	1.00	1.00	1.00	1.00	1.00	1.00
Initial Bse:	15	612	73	145	1043	0	0	0	0	81	0	78
Added Vol:	0	42	0	0	80	0	0	0	0	0	0	0
PasserByVol:	0	0	0	0	0	0	0	0	0	0	0	0
Initial Fut:	15	654	73	145	1123	0	0	0	0	81	0	78
User Adj:	1.00	1.00	1.00	1.00	1.00	1.00	1.00	1.00	1.00	1.00	1.00	1.00
PHF Adj:	1.00	1.00	1.00	1.00	1.00	1.00	1.00	1.00	1.00	1.00	1.00	1.00
PHF Volume:	15	654	73	145	1123	0	0	0	0	81	0	78
Reduct Vol:	0	0	0	0	0	0	0	0	0	0	0	0
Reduced Vol:	15	654	73	145	1123	0	0	0	0	81	0	78
PCE Adj:	1.00	1.00	1.00	1.00	1.00	1.00	1.00	1.00	1.00	1.00	1.00	1.00
MLF Adj:	1.00	1.00	1.00	1.00	1.00	1.00	1.00	1.00	1.00	1.00	1.00	1.00
FinalVolume:	15	654	73	145	1123	0	0	0	0	81	0	78

Saturation Flow Module:												
Sat/Lane:	1900	1900	1900	1900	1900	1900	1900	1900	1900	1900	1900	1900
Adjustment:	0.92	1.00	0.92	0.92	1.00	0.92	0.92	1.00	0.92	0.92	1.00	0.92
Lanes:	1.00	2.00	1.00	1.00	2.00	0.00	0.00	0.00	0.00	1.00	0.00	1.00
Final Sat.:	1750	3800	1750	1750	3800	0	0	0	0	1750	0	1750

Capacity Analysis Module:												
Vol/Sat:	0.01	0.17	0.04	0.08	0.30	0.00	0.00	0.00	0.00	0.05	0.00	0.04
Crit Moves:	****			****			****			****		
Green Time:	7.0	59.0	59.0	28.4	80.4	0.0	0.0	0.0	0.0	12.6	0.0	13.3
Volume/Cap:	0.12	0.29	0.07	0.29	0.37	0.00	0.00	0.00	0.00	0.37	0.00	0.34
Uniform Del:	43.6	10.2	8.8	27.9	2.7	0.0	0.0	0.0	0.0	40.1	0.0	39.3
IncrementDel:	0.5	0.1	0.0	0.3	0.1	0.0	0.0	0.0	0.0	1.0	0.0	0.9
InitQueueDel:	0.0	0.0	0.0	0.0	0.0	0.0	0.0	0.0	0.0	0.0	0.0	0.0
Delay Adj:	1.00	1.00	1.00	1.00	1.00	0.00	0.00	0.00	0.00	1.00	0.00	1.00
Delay/Veh:	44.1	10.2	8.8	28.3	2.8	0.0	0.0	0.0	0.0	41.1	0.0	40.2
User DelAdj:	1.00	1.00	1.00	1.00	1.00	1.00	1.00	1.00	1.00	1.00	1.00	1.00
AdjDel/Veh:	44.1	10.2	8.8	28.3	2.8	0.0	0.0	0.0	0.0	41.1	0.0	40.2
LOS by Move:	D	B+	A	C	A	A	A	A	A	D	A	D
HCM2kAvgQ:	0	5	1	4	5	0	0	0	0	3	0	3

\*\*\*\*\*  
 Note: Queue reported is the number of cars per lane.  
 \*\*\*\*\*

## Level of Service Computation Report

## 2000 HCM Operations Method (Future Volume Alternative)

\*\*\*\*\*  
 Intersection #10 San Felipe Road/Yerba Buena Avenue  
 \*\*\*\*\*

Cycle (sec): 100 Critical Vol./Cap.(X): 0.690  
 Loss Time (sec): 0 Average Delay (sec/veh): 19.6  
 Optimal Cycle: 73 Level of Service: B-  
 \*\*\*\*\*

Street Name:	San Felipe Road						Yerba Buena Avenue					
Approach:	North Bound			South Bound			East Bound			West Bound		
Movement:	L	T	R	L	T	R	L	T	R	L	T	R
Control:	Protected			Protected			Protected			Protected		
Rights:	Include			Include			Include			Include		
Min. Green:	7	10	10	7	10	10	7	10	10	7	10	10
Y+R:	4.0	4.0	4.0	4.0	4.0	4.0	4.0	4.0	4.0	4.0	4.0	4.0
Lanes:	1	0	2	0	1	0	1	0	0	0	0	0

Volume Module:	San Felipe Road			San Felipe Road			Yerba Buena Avenue			Yerba Buena Avenue		
Base Vol:	50	627	0	1	1126	216	138	0	69	0	0	0
Growth Adj:	1.00	1.00	1.00	1.00	1.00	1.00	1.00	1.00	1.00	1.00	1.00	1.00
Initial Bse:	50	627	0	1	1126	216	138	0	69	0	0	0
Added Vol:	0	42	0	0	80	0	0	0	0	0	0	0
PasserByVol:	0	0	0	0	0	0	0	0	0	0	0	0
Initial Fut:	50	669	0	1	1206	216	138	0	69	0	0	0
User Adj:	1.00	1.00	1.00	1.00	1.00	1.00	1.00	1.00	1.00	1.00	1.00	1.00
PHF Adj:	1.00	1.00	1.00	1.00	1.00	1.00	1.00	1.00	1.00	1.00	1.00	1.00
PHF Volume:	50	669	0	1	1206	216	138	0	69	0	0	0
Reduct Vol:	0	0	0	0	0	0	0	0	0	0	0	0
Reduced Vol:	50	669	0	1	1206	216	138	0	69	0	0	0
PCE Adj:	1.00	1.00	1.00	1.00	1.00	1.00	1.00	1.00	1.00	1.00	1.00	1.00
MLF Adj:	1.00	1.00	1.00	1.00	1.00	1.00	1.00	1.00	1.00	1.00	1.00	1.00
FinalVolume:	50	669	0	1	1206	216	138	0	69	0	0	0

Saturation Flow Module:	San Felipe Road			San Felipe Road			Yerba Buena Avenue			Yerba Buena Avenue		
Sat/Lane:	1900	1900	1900	1900	1900	1900	1900	1900	1900	1900	1900	1900
Adjustment:	0.92	1.00	0.92	0.95	0.95	0.95	0.92	0.92	0.92	0.92	1.00	0.92
Lanes:	1.00	2.00	0.00	0.01	1.69	0.30	0.67	0.00	0.33	0.00	0.00	0.00
Final Sat.:	1750	3800	0	3	3051	546	1167	0	583	0	0	0

Capacity Analysis Module:	San Felipe Road			San Felipe Road			Yerba Buena Avenue			Yerba Buena Avenue		
Vol/Sat:	0.03	0.18	0.00	0.40	0.40	0.40	0.12	0.00	0.12	0.00	0.00	0.00
Crit Moves:	****			****			****					
Green Time:	12.5	25.5	0.0	57.3	70.4	70.4	17.2	0.0	17.1	0.0	0.0	0.0
Volume/Cap:	0.23	0.69	0.00	0.69	0.56	0.56	0.69	0.00	0.69	0.00	0.00	0.00
Uniform Del:	39.4	33.7	0.0	15.1	7.3	7.3	38.9	0.0	39.0	0.0	0.0	0.0
IncrementDel:	0.5	2.1	0.0	1.0	0.3	0.3	6.7	0.0	6.9	0.0	0.0	0.0
InitQueueDel:	0.0	0.0	0.0	0.0	0.0	0.0	0.0	0.0	0.0	0.0	0.0	0.0
Delay Adj:	1.00	1.00	0.00	1.00	1.00	1.00	1.00	0.00	1.00	0.00	0.00	0.00
Delay/Veh:	40.0	35.8	0.0	16.1	7.5	7.5	45.6	0.0	45.9	0.0	0.0	0.0
User DelAdj:	1.00	1.00	1.00	1.00	1.00	1.00	1.00	1.00	1.00	1.00	1.00	1.00
AdjDel/Veh:	40.0	35.8	0.0	16.1	7.5	7.5	45.6	0.0	45.9	0.0	0.0	0.0
LOS by Move:	D	D+	A	B	A	A	D	A	D	A	A	A
HCM2kAvgQ:	1	9	0	16	11	11	8	0	8	0	0	0

\*\*\*\*\*  
 Note: Queue reported is the number of cars per lane.  
 \*\*\*\*\*

Level Of Service Computation Report  
 2000 HCM Operations Method (Future Volume Alternative)

\*\*\*\*\*  
 Intersection #11 Aborn Road/White Road/San Felipe Road  
 \*\*\*\*\*

Cycle (sec): 155 Critical Vol./Cap.(X): 0.747  
 Loss Time (sec): 0 Average Delay (sec/veh): 50.0  
 Optimal Cycle: 90 Level Of Service: D  
 \*\*\*\*\*

Street Name:	San Felipe Road						Aborn Road					
Approach:	North Bound			South Bound			East Bound			West Bound		
Movement:	L	T	R	L	T	R	L	T	R	L	T	R
Control:	Protected			Protected			Protected			Protected		
Rights:	Include			Include			Include			Include		
Min. Green:	7	10	10	7	10	10	7	10	10	7	10	10
Y+R:	4.0	4.0	4.0	4.0	4.0	4.0	4.0	4.0	4.0	4.0	4.0	4.0
Lanes:	2	0	2	0	1	2	0	2	0	1	2	0

Volume Module:

Base Vol:	379	494	84	174	699	323	457	734	447	249	497	120
Growth Adj:	1.00	1.00	1.00	1.00	1.00	1.00	1.00	1.00	1.00	1.00	1.00	1.00
Initial Bse:	379	494	84	174	699	323	457	734	447	249	497	120
Added Vol:	21	13	8	0	25	0	0	0	40	15	0	0
PasserByVol:	0	0	0	0	0	0	0	0	0	0	0	0
Initial Fut:	400	507	92	174	724	323	457	734	487	264	497	120
User Adj:	1.00	1.00	1.00	1.00	1.00	1.00	1.00	1.00	1.00	1.00	1.00	1.00
PHF Adj:	1.00	1.00	1.00	1.00	1.00	1.00	1.00	1.00	1.00	1.00	1.00	1.00
PHF Volume:	400	507	92	174	724	323	457	734	487	264	497	120
Reduct Vol:	0	0	0	0	0	0	0	0	0	0	0	0
Reduced Vol:	400	507	92	174	724	323	457	734	487	264	497	120
PCE Adj:	1.00	1.00	1.00	1.00	1.00	1.00	1.00	1.00	1.00	1.00	1.00	1.00
MLF Adj:	1.00	1.00	1.00	1.00	1.00	1.00	1.00	1.00	1.00	1.00	1.00	1.00
FinalVolume:	400	507	92	174	724	323	457	734	487	264	497	120

Saturation Flow Module:

Sat/Lane:	1900	1900	1900	1900	1900	1900	1900	1900	1900	1900	1900	1900
Adjustment:	0.83	1.00	0.92	0.83	1.00	0.92	0.83	1.00	0.92	0.92	1.00	0.92
Lanes:	2.00	2.00	1.00	2.00	2.00	1.00	2.00	3.00	1.00	1.00	3.00	1.00
Final Sat.:	3150	3800	1750	3150	3800	1750	3150	5700	1750	1750	5700	1750

Capacity Analysis Module:

Vol/Sat:	0.13	0.13	0.05	0.06	0.19	0.18	0.15	0.13	0.28	0.15	0.09	0.07
Crit Moves:	****			****			****		****	****		
Green Time:	26.4	46.6	46.6	19.3	39.6	39.6	55.6	57.8	57.8	31.3	33.4	33.4
Volume/Cap:	0.75	0.44	0.17	0.44	0.75	0.72	0.40	0.35	0.75	0.75	0.40	0.32
Uniform Del:	61.1	43.7	40.0	62.9	53.1	52.7	37.2	35.0	42.3	58.1	52.2	51.2
IncrementDel:	5.7	0.3	0.2	0.8	3.2	5.8	0.2	0.1	4.7	8.5	0.2	0.5
InitQueueDel:	0.0	0.0	0.0	0.0	0.0	0.0	0.0	0.0	0.0	0.0	0.0	0.0
Delay Adj:	1.00	1.00	1.00	1.00	1.00	1.00	1.00	1.00	1.00	1.00	1.00	1.00
Delay/Veh:	66.9	44.0	40.2	63.7	56.3	58.5	37.5	35.1	47.0	66.6	52.4	51.7
User DelAdj:	1.00	1.00	1.00	1.00	1.00	1.00	1.00	1.00	1.00	1.00	1.00	1.00
AdjDel/Veh:	66.9	44.0	40.2	63.7	56.3	58.5	37.5	35.1	47.0	66.6	52.4	51.7
LOS by Move:	E	D	D	E	E+	E+	D+	D+	D	E	D-	D-
HCM2kAvgQ:	11	9	3	5	17	16	9	8	21	14	7	5

\*\*\*\*\*  
 Note: Queue reported is the number of cars per lane.  
 \*\*\*\*\*



Level Of Service Computation Report  
2000 HCM Operations Method (Future Volume Alternative)

\*\*\*\*\*  
Intersection #12 Aborn Road/Nieman Boulevard  
\*\*\*\*\*

Cycle (sec): 170 Critical Vol./Cap.(X): 0.652  
Loss Time (sec): 0 Average Delay (sec/veh): 40.5  
Optimal Cycle: 65 Level Of Service: D  
\*\*\*\*\*

Street Name:	Nieman Boulevard						Aborn Road					
Approach:	North Bound			South Bound			East Bound			West Bound		
Movement:	L	T	R	L	T	R	L	T	R	L	T	R
Control:	Protected			Protected			Protected			Protected		
Rights:	Include			Include			Include			Include		
Min. Green:	7	10	10	7	10	10	7	10	10	7	10	10
Y+R:	4.0	4.0	4.0	4.0	4.0	4.0	4.0	4.0	4.0	4.0	4.0	4.0
Lanes:	1	0	2	0	1	1	1	0	2	1	0	1

Volume Module:

Base Vol:	57	88	137	291	206	72	24	1575	82	159	1053	198
Growth Adj:	1.00	1.00	1.00	1.00	1.00	1.00	1.00	1.00	1.00	1.00	1.00	1.00
Initial Bse:	57	88	137	291	206	72	24	1575	82	159	1053	198
Added Vol:	0	6	0	34	11	0	0	6	0	0	3	18
PasserByVol:	0	0	0	0	0	0	0	0	0	0	0	0
Initial Fut:	57	94	137	325	217	72	24	1581	82	159	1056	216
User Adj:	1.00	1.00	1.00	1.00	1.00	1.00	1.00	1.00	1.00	1.00	1.00	1.00
PHF Adj:	1.00	1.00	1.00	1.00	1.00	1.00	1.00	1.00	1.00	1.00	1.00	1.00
PHF Volume:	57	94	137	325	217	72	24	1581	82	159	1056	216
Reduct Vol:	0	0	0	0	0	0	0	0	0	0	0	0
Reduced Vol:	57	94	137	325	217	72	24	1581	82	159	1056	216
PCE Adj:	1.00	1.00	1.00	1.00	1.00	1.00	1.00	1.00	1.00	1.00	1.00	1.00
MLF Adj:	1.00	1.00	1.00	1.00	1.00	1.00	1.00	1.00	1.00	1.00	1.00	1.00
FinalVolume:	57	94	137	325	217	72	24	1581	82	159	1056	216

Saturation Flow Module:

Sat/Lane:	1900	1900	1900	1900	1900	1900	1900	1900	1900	1900	1900	1900
Adjustment:	0.92	1.00	0.92	0.92	1.00	0.92	0.92	0.98	0.95	0.92	1.00	0.92
Lanes:	1.00	2.00	1.00	1.00	2.00	1.00	1.00	2.85	0.15	1.00	3.00	1.00
Final Sat.:	1750	3800	1750	1750	3800	1750	1750	5324	276	1750	5700	1750

Capacity Analysis Module:

Vol/Sat:	0.03	0.02	0.08	0.19	0.06	0.04	0.01	0.30	0.30	0.09	0.19	0.12
Crit Moves:	****			****			****			****		
Green Time:	28.4	20.4	20.4	48.4	40.5	40.5	18.4	77.5	77.5	23.7	82.8	82.8
Volume/Cap:	0.20	0.21	0.65	0.65	0.24	0.17	0.13	0.65	0.65	0.65	0.38	0.25
Uniform Del:	61.0	67.5	71.4	53.4	52.3	51.4	68.5	35.8	35.8	69.2	27.5	25.5
IncrementDel:	0.3	0.2	7.1	3.1	0.1	0.2	0.3	0.6	0.6	6.2	0.1	0.2
InitQueueDel:	0.0	0.0	0.0	0.0	0.0	0.0	0.0	0.0	0.0	0.0	0.0	0.0
Delay Adj:	1.00	1.00	1.00	1.00	1.00	1.00	1.00	1.00	1.00	1.00	1.00	1.00
Delay/Veh:	61.3	67.7	78.5	56.4	52.4	51.6	68.8	36.4	36.4	75.4	27.6	25.7
User DelAdj:	1.00	1.00	1.00	1.00	1.00	1.00	1.00	1.00	1.00	1.00	1.00	1.00
AdjDel/Veh:	61.3	67.7	78.5	56.4	52.4	51.6	68.8	36.4	36.4	75.4	27.6	25.7
LOS by Move:	E	E	E-	E+	D-	D-	E	D+	D+	E-	C	C
HCM2kAvgQ:	3	2	8	16	4	3	1	21	21	8	11	7

\*\*\*\*\*  
Note: Queue reported is the number of cars per lane.  
\*\*\*\*\*

Level Of Service Computation Report  
 2000 HCM Operations Method (Future Volume Alternative)

\*\*\*\*\*  
 Intersection #13 Capitol Expressway/Aborn Road  
 \*\*\*\*\*

Cycle (sec): 190 Critical Vol./Cap.(X): 1.051  
 Loss Time (sec): 0 Average Delay (sec/veh): 67.4  
 Optimal Cycle: 180 Level Of Service: E  
 \*\*\*\*\*

Street Name:	Capitol Expresswa						Aborn Road									
Approach:	North Bound			South Bound			East Bound			West Bound						
Movement:	L	T	R	L	T	R	L	T	R	L	T	R				
Control:	Protected			Protected			Protected			Protected						
Rights:	Include			Include			Include			Include						
Min. Green:	7	10	10	7	10	10	7	10	10	7	10	10				
Y+R:	4.0	4.0	4.0	4.0	4.0	4.0	4.0	4.0	4.0	4.0	4.0	4.0				
Lanes:	1	0	4	0	1	2	0	3	1	0	1	2	0	2	0	1

Volume Module:

Base Vol:	204	1403	1105	320	1575	82	232	434	164	636	475	90
Growth Adj:	1.00	1.00	1.00	1.00	1.00	1.00	1.00	1.00	1.00	1.00	1.00	1.00
Initial Bse:	204	1403	1105	320	1575	82	232	434	164	636	475	90
Added Vol:	0	0	0	0	0	0	0	6	0	0	3	0
PasserByVol:	0	0	0	0	0	0	0	0	0	0	0	0
Initial Fut:	204	1403	1105	320	1575	82	232	440	164	636	478	90
User Adj:	1.00	1.00	1.00	1.00	1.00	1.00	1.00	1.00	1.00	1.00	1.00	1.00
PHF Adj:	1.00	1.00	1.00	1.00	1.00	1.00	1.00	1.00	1.00	1.00	1.00	1.00
PHF Volume:	204	1403	1105	320	1575	82	232	440	164	636	478	90
Reduct Vol:	0	0	0	0	0	0	0	0	0	0	0	0
Reduced Vol:	204	1403	1105	320	1575	82	232	440	164	636	478	90
PCE Adj:	1.00	1.00	1.00	1.00	1.00	1.00	1.00	1.00	1.00	1.00	1.00	1.00
MLF Adj:	1.00	1.00	1.00	1.00	1.00	1.00	1.00	1.00	1.00	1.00	1.00	1.00
FinalVolume:	204	1403	1105	320	1575	82	232	440	164	636	478	90

Saturation Flow Module:

Sat/Lane:	1900	1900	1900	1900	1900	1900	1900	1900	1900	1900	1900	1900
Adjustment:	0.92	1.00	0.92	0.83	0.99	0.95	0.92	1.00	0.92	0.83	1.00	0.92
Lanes:	1.00	4.00	1.00	2.00	3.79	0.21	1.00	2.00	1.00	2.00	2.00	1.00
Final Sat.:	1750	7600	1750	3150	7128	371	1750	3800	1750	3150	3800	1750

Capacity Analysis Module:

Vol/Sat:	0.12	0.18	0.63	0.10	0.22	0.22	0.13	0.12	0.09	0.20	0.13	0.05
Crit Moves:	****			****			****			****		
Green Time:	45.8	114	114.2	18.4	86.8	86.8	29.5	20.9	20.9	36.5	28.0	28.0
Volume/Cap:	0.48	0.31	1.05	1.05	0.48	0.48	0.85	1.05	0.85	1.05	0.85	0.35
Uniform Del:	58.7	17.6	35.9	81.3	34.1	34.1	74.1	80.1	78.6	72.7	74.9	69.0
IncrementDel:	0.9	0.0	42.1	65.5	0.1	0.1	22.3	57.9	28.4	50.6	12.2	0.8
InitQueueDel:	0.0	0.0	0.0	0.0	0.0	0.0	0.0	0.0	0.0	0.0	0.0	0.0
Delay Adj:	1.00	1.00	1.00	1.00	1.00	1.00	1.00	1.00	1.00	1.00	1.00	1.00
Delay/Veh:	59.6	17.6	78.0	146.8	34.2	34.2	96.3	138	107.0	123.3	87.1	69.8
User DelAdj:	1.00	1.00	1.00	1.00	1.00	1.00	1.00	1.00	1.00	1.00	1.00	1.00
AdjDel/Veh:	59.6	17.6	78.0	146.8	34.2	34.2	96.3	138	107.0	123.3	87.1	69.8
LOS by Move:	E+	B	E-	F	C-	C-	F	F	F	F	F	E
HCM2kAvgQ:	10	9	75	15	16	16	16	17	12	26	14	5

\*\*\*\*\*  
 Note: Queue reported is the number of cars per lane.  
 \*\*\*\*\*

Level Of Service Computation Report  
 2000 HCM Operations Method (Future Volume Alternative)

\*\*\*\*\*  
 Intersection #14 Capitol Expressway/Silver Creek Road  
 \*\*\*\*\*

Cycle (sec): 190 Critical Vol./Cap.(X): 0.834  
 Loss Time (sec): 0 Average Delay (sec/veh): 52.3  
 Optimal Cycle: 137 Level Of Service: D-  
 \*\*\*\*\*

Street Name:	Capitol Expresswa						Silver Creek Road					
Approach:	North Bound			South Bound			East Bound			West Bound		
Movement:	L	T	R	L	T	R	L	T	R	L	T	R
Control:	Protected			Protected			Protected			Protected		
Rights:	Include			Include			Include			Include		
Min. Green:	7	10	10	7	10	10	7	10	10	7	10	10
Y+R:	4.0	4.0	4.0	4.0	4.0	4.0	4.0	4.0	4.0	4.0	4.0	4.0
Lanes:	2	0	4	0	1	2	0	4	0	1	2	0

Volume Module:

Base Vol:	686	2504	525	220	2119	51	95	338	382	364	279	122
Growth Adj:	1.00	1.00	1.00	1.00	1.00	1.00	1.00	1.00	1.00	1.00	1.00	1.00
Initial Bse:	686	2504	525	220	2119	51	95	338	382	364	279	122
Added Vol:	0	0	0	0	0	0	0	6	0	11	3	0
PasserByVol:	0	0	0	0	0	0	0	0	0	0	0	0
Initial Fut:	686	2504	545	220	2119	51	95	344	382	375	282	122
User Adj:	1.00	1.00	1.00	1.00	1.00	1.00	1.00	1.00	1.00	1.00	1.00	1.00
PHF Adj:	1.00	1.00	1.00	1.00	1.00	1.00	1.00	1.00	1.00	1.00	1.00	1.00
PHF Volume:	686	2504	545	220	2119	51	95	344	382	375	282	122
Reduct Vol:	0	0	0	0	0	0	0	0	0	0	0	0
Reduced Vol:	686	2504	545	220	2119	51	95	344	382	375	282	122
PCE Adj:	1.00	1.00	1.00	1.00	1.00	1.00	1.00	1.00	1.00	1.00	1.00	1.00
MLF Adj:	1.00	1.00	1.00	1.00	1.00	1.00	1.00	1.00	1.00	1.00	1.00	1.00
FinalVolume:	686	2504	545	220	2119	51	95	344	382	375	282	122

Saturation Flow Module:

Sat/Lane:	1900	1900	1900	1900	1900	1900	1900	1900	1900	1900	1900	1900
Adjustment:	0.83	1.00	0.92	0.83	1.00	0.92	0.83	1.00	0.92	0.83	0.99	0.95
Lanes:	2.00	4.00	1.00	2.00	4.00	1.00	2.00	2.00	1.00	2.00	1.38	0.62
Final Sat.:	3150	7600	1750	3150	7600	1750	3150	3800	1750	3150	2582	1117

Capacity Analysis Module:

Vol/Sat:	0.22	0.33	0.31	0.07	0.28	0.03	0.03	0.09	0.22	0.12	0.11	0.11
Crit Moves:	****			****			****		****	****		
Green Time:	49.6	93.4	93.4	19.8	63.5	63.5	20.2	49.7	49.7	27.1	56.7	56.7
Volume/Cap:	0.83	0.67	0.63	0.67	0.83	0.09	0.28	0.35	0.83	0.83	0.37	0.37
Uniform Del:	62.8	34.7	33.8	77.7	55.3	41.1	74.1	53.9	62.7	75.1	49.7	49.7
IncrementDel:	7.3	0.5	1.6	5.3	2.5	0.1	0.5	0.1	7.0	12.6	0.2	0.2
InitQueueDel:	0.0	0.0	0.0	0.0	0.0	0.0	0.0	0.0	0.0	0.0	0.0	0.0
Delay Adj:	1.00	1.00	1.00	1.00	1.00	1.00	1.00	1.00	1.00	1.00	1.00	1.00
Delay/Veh:	70.2	35.2	35.4	83.0	57.8	41.1	74.6	54.0	69.7	87.7	50.0	50.0
User DelAdj:	1.00	1.00	1.00	1.00	1.00	1.00	1.00	1.00	1.00	1.00	1.00	1.00
AdjDel/Veh:	70.2	35.2	35.4	83.0	57.8	41.1	74.6	54.0	69.7	87.7	50.0	50.0
LOS by Move:	E	D+	D+	F	E+	D	E	D-	E	F	D	D
HCM2kAvgQ:	23	26	24	7	27	2	3	8	23	14	9	9

\*\*\*\*\*  
 Note: Queue reported is the number of cars per lane.  
 \*\*\*\*\*

## Scenario Report

Scenario: Cumulative AM

Command: Default Command  
 Volume: Future AM  
 Geometry: Existing  
 Impact Fee: Default Impact Fee  
 Trip Generation: Existing  
 Trip Distribution: Project  
 Paths: Project  
 Routes: Default Route  
 Configuration: Default Configuration

Impact Analysis Report  
Level Of Service

Intersection		Base		Future		Change in
		Del/	V/	Del/	V/	
		LOS	Veh	LOS	Veh	
# 1 U.S. 101 SB Off-ramp/Yerba Bue	F	92.9	1.159	F 92.9	1.159	+ 0.000 D/V
# 2 U.S. 101 NB Off-ramp/Yerba Bue	B	14.2	0.712	B 14.2	0.712	+ 0.000 D/V
# 3 Silver Creek Road/Yerba Buena	B	17.7	0.810	B 17.7	0.810	+ 0.000 D/V
# 4 Nieman Boulevard/Silver Creek	C	28.3	0.790	C 28.3	0.790	+ 0.000 D/V
# 5 Byington Drive/Yerba Buena Ave	B+	10.2	0.645	B+ 10.2	0.645	+ 0.000 D/V
# 6 San Felipe Road/Yerba Buena Ro	E	67.2	1.081	E 67.2	1.081	+ 0.000 D/V
# 7 Paseo de Arboles/San Felipe Ro	B	13.4	0.450	B 13.4	0.450	+ 0.000 D/V
# 8 Delta Road/San Felipe Road	B-	19.0	0.529	B- 19.0	0.529	+ 0.000 D/V
# 9 Fowler Road/San Felipe Road	B	15.3	0.447	B 15.3	0.447	+ 0.000 D/V
# 10 San Felipe Road/Yerba Buena Av	C+	20.1	0.658	C+ 20.1	0.658	+ 0.000 D/V
# 11 Aborn Road/White Road/San Feli	D-	54.6	0.922	D- 54.6	0.922	+ 0.000 D/V
# 12 Aborn Road/Nieman Boulevard	D+	36.3	0.746	D+ 36.3	0.746	+ 0.000 D/V
# 13 Capitol Expressway/Aborn Road	F	181.8	1.553	F 181.8	1.553	+ 0.000 D/V
# 14 Capitol Expressway/Silver Cree	E+	55.8	0.939	E+ 55.8	0.939	+ 0.000 D/V

Level of Service Computation Report
2000 HCM Operations Method (Base Volume Alternative)

Intersection #1 U.S. 101 SB Off-ramp/Yerba Buena Road

Cycle (sec): 100 Critical Vol./Cap.(X): 1.159
Loss Time (sec): 0 Average Delay (sec/veh): 92.9
Optimal Cycle: 180 Level of Service: F

Table with columns for Street Name, Approach, Movement, Control, Rights, Min. Green, Y+R, Lanes. Rows include U.S. 101 SB Off-ramp and Yerba Buena Road with various movement details.

Volume Module: Base Vol, Growth Adj, Initial Bse, User Adj, PHF Adj, PHF Volume, Reduct Vol, Reduced Vol, PCE Adj, MLF Adj, Final Volume.

Saturation Flow Module: Sat/Lane, Adjustment, Lanes, Final Sat.

Capacity Analysis Module: Vol/Sat, Crit Moves, Green Time, Volume/Cap, Uniform Del, IncremntDel, InitQueuDel, Delay Adj, Delay/Veh, User DelAdj, AdjDel/Veh, LOS by Move, HCM2kAvgQ.

Note: Queue reported is the number of cars per lane.

Level of Service Computation Report
2000 HCM Operations Method (Base Volume Alternative)

Intersection #2 U.S. 101 NB Off-ramp/Yerba Buena Road

Cycle (sec): 100 Critical Vol./Cap.(X): 0.712
Loss Time (sec): 0 Average Delay (sec/veh): 14.2
Optimal Cycle: 79 Level of Service: B

Table with columns for Street Name, Approach, Movement, Control, Rights, Min. Green, Y+R, Lanes. Rows include U.S. 101 NB Off-ramp and Yerba Buena Road with various movement details.

Volume Module: Base Vol, Growth Adj, Initial Bse, User Adj, PHF Adj, PHF Volume, Reduct Vol, Reduced Vol, PCE Adj, MLF Adj, Final Volume.

Saturation Flow Module: Sat/Lane, Adjustment, Lanes, Final Sat.

Capacity Analysis Module: Vol/Sat, Crit Moves, Green Time, Volume/Cap, Uniform Del, IncremntDel, InitQueuDel, Delay Adj, Delay/Veh, User DelAdj, AdjDel/Veh, LOS by Move, HCM2kAvgQ.

Note: Queue reported is the number of cars per lane.

Level of Service Computation Report
2000 HCM Operations Method (Base Volume Alternative)

Intersection #3 Silver Creek Road/Yerba Buena Road

Cycle (sec): 100 Critical Vol./Cap.(X): 0.810
Loss Time (sec): 0 Average Delay (sec/veh): 17.7
Optimal Cycle: 120 Level of Service: B

Table with columns for Street Name, Approach, Movement, Control, Rights, Min. Green, Y+R, Lanes. Rows include Silver Creek Road and Yerba Buena Road with North and South Bound movements.

Table with columns for Volume Module, Base Vol, Growth Adj, Initial Bse, User Adj, PHF Adj, PHF Volume, Reduct Vol, Reduced Vol, PCE Adj, MLF Adj, Final Volume.

Table with columns for Sat/Lane, Adjustment, Lanes, Final Sat. for Saturation Flow Module.

Table with columns for Vol/Sat, Crit Moves, Green Time, Volume/Cap, Uniform Del, IncremntDel, InitQueuDel, Delay Adj, Delay/Veh, User DelAdj, AdjDel/Veh, LOS by Move, HCM2kAvgQ for Capacity Analysis Module.

Note: Queue reported is the number of cars per lane.

Level of Service Computation Report
2000 HCM Operations Method (Base Volume Alternative)

Intersection #4 Nieman Boulevard/Silver Creek Valley Road/Yerba Buena Road

Cycle (sec): 100 Critical Vol./Cap.(X): 0.790
Loss Time (sec): 0 Average Delay (sec/veh): 28.3
Optimal Cycle: 108 Level of Service: C

Table with columns for Street Name, Approach, Movement, Control, Rights, Min. Green, Y+R, Lanes. Rows include Nieman Boulevard and Yerba Buena Road with North and South Bound movements.

Table with columns for Volume Module, Base Vol, Growth Adj, Initial Bse, User Adj, PHF Adj, PHF Volume, Reduct Vol, Reduced Vol, PCE Adj, MLF Adj, Final Volume.

Table with columns for Sat/Lane, Adjustment, Lanes, Final Sat. for Saturation Flow Module.

Table with columns for Vol/Sat, Crit Moves, Green Time, Volume/Cap, Uniform Del, IncremntDel, InitQueuDel, Delay Adj, Delay/Veh, User DelAdj, AdjDel/Veh, LOS by Move, HCM2kAvgQ for Capacity Analysis Module.

Note: Queue reported is the number of cars per lane.

Level of Service Computation Report
2000 HCM Operations Method (Base Volume Alternative)

Intersection #5 Byington Drive/Yerba Buena Avenue/Yerba Buena Road

Cycle (sec): 100 Critical Vol./Cap.(X): 0.645
Loss Time (sec): 0 Average Delay (sec/veh): 10.2
Optimal Cycle: 64 Level of Service: B+

Table with columns for Street Name, Approach, Movement, Control, Rights, Min. Green, Y+R, Lanes for Byington Drive and Yerba Buena Avenue.

Table for Volume Module showing Base Vol, Growth Adj, Initial Bse, User Adj, PHF Adj, PHF Volume, Reduct Vol, Reduced Vol, PCE Adj, MLF Adj, Final Volume.

Table for Saturation Flow Module showing Sat/Lane, Adjustment, Lanes, Final Sat.

Table for Capacity Analysis Module showing Vol/Sat, Crit Moves, Green Time, Volume/Cap, Uniform Del, IncremntDel, InitQueueDel, Delay Adj, User DelAdj, AdjDel/Veh, LOS by Move, HCM2kAvgQ.

Note: Queue reported is the number of cars per lane.

Level of Service Computation Report
2000 HCM Operations Method (Base Volume Alternative)

Intersection #6 San Felipe Road/Yerba Buena Road

Cycle (sec): 120 Critical Vol./Cap.(X): 1.081
Loss Time (sec): 0 Average Delay (sec/veh): 67.2
Optimal Cycle: 180 Level of Service: E

Table with columns for Street Name, Approach, Movement, Control, Rights, Min. Green, Y+R, Lanes for San Felipe Road and Yerba Buena Road.

Table for Volume Module showing Base Vol, Growth Adj, Initial Bse, User Adj, PHF Adj, PHF Volume, Reduct Vol, Reduced Vol, PCE Adj, MLF Adj, Final Volume.

Table for Saturation Flow Module showing Sat/Lane, Adjustment, Lanes, Final Sat.

Table for Capacity Analysis Module showing Vol/Sat, Crit Moves, Green Time, Volume/Cap, Uniform Del, IncremntDel, InitQueueDel, Delay Adj, User DelAdj, AdjDel/Veh, LOS by Move, HCM2kAvgQ.

Note: Queue reported is the number of cars per lane.

Level of Service Computation Report
2000 HCM Operations Method (Base Volume Alternative)

Intersection #7 Paseo de Arboles/San Felipe Road

Cycle (sec): 100 Critical Vol./Cap.(X): 0.450
Loss Time (sec): 0 Average Delay (sec/veh): 13.4
Optimal Cycle: 41 Level of Service: B

Table with columns for Street Name, Approach, Movement, Control, Rights, Min. Green, Y+R, Lanes. Rows for San Felipe Road and Paseo de Arboles.

Table with columns for Volume Module, Base Vol, Growth Adj, Initial Bse, User Adj, PHF Adj, PHF Volume, Reduct Vol, Reduced Vol, PCE Adj, MLF Adj, Final Volume.

Table with columns for Sat/Lane, Adjustment, Lanes, Final Sat. for Saturation Flow Module.

Table with columns for Vol/Sat, Crit Moves, Green Time, Volume/Cap, Uniform Del, IncremntDel, InitQueuDel, Delay Adj, Delay/Veh, User DelAdj, AdjDel/Veh, LOS by Move, HCM2kAvgQ for Capacity Analysis Module.

Note: Queue reported is the number of cars per lane.

Level of Service Computation Report
2000 HCM Operations Method (Base Volume Alternative)

Intersection #8 Delta Road/San Felipe Road

Cycle (sec): 100 Critical Vol./Cap.(X): 0.529
Loss Time (sec): 0 Average Delay (sec/veh): 19.0
Optimal Cycle: 48 Level of Service: B-

Table with columns for Street Name, Approach, Movement, Control, Rights, Min. Green, Y+R, Lanes. Rows for San Felipe Road and Delta Road.

Table with columns for Volume Module, Base Vol, Growth Adj, Initial Bse, User Adj, PHF Adj, PHF Volume, Reduct Vol, Reduced Vol, PCE Adj, MLF Adj, Final Volume.

Table with columns for Sat/Lane, Adjustment, Lanes, Final Sat. for Saturation Flow Module.

Table with columns for Vol/Sat, Crit Moves, Green Time, Volume/Cap, Uniform Del, IncremntDel, InitQueuDel, Delay Adj, Delay/Veh, User DelAdj, AdjDel/Veh, LOS by Move, HCM2kAvgQ for Capacity Analysis Module.

Note: Queue reported is the number of cars per lane.



Level of Service Computation Report
2000 HCM Operations Method (Base Volume Alternative)

Intersection #9 Fowler Road/San Felipe Road

Cycle (sec): 100 Critical Vol./Cap.(X): 0.447
Loss Time (sec): 0 Average Delay (sec/veh): 15.3
Optimal Cycle: 41 Level of Service: B

Table with columns for Street Name, Approach, Movement, Control, Rights, Min. Green, Y+R, Lanes. Rows for San Felipe Road (North/South Bound) and Fowler Road (East/West Bound).

Table for Volume Module showing Base Vol, Growth Adj, Initial Bse, User Adj, PHF Adj, PHF Volume, Reduct Vol, Reduced Vol, PCE Adj, MLF Adj, Final Volume.

Table for Saturation Flow Module showing Sat/Lane, Adjustment, Lanes, Final Sat.

Table for Capacity Analysis Module showing Vol/Sat, Crit Moves, Green Time, Volume/Cap, Uniform Del, IncremntDel, InitQueuDel, Delay Adj, Delay/Veh, User DelAdj, AdjDel/Veh, LOS by Move, HCM2kAvgQ.

Note: Queue reported is the number of cars per lane.

Level of Service Computation Report
2000 HCM Operations Method (Base Volume Alternative)

Intersection #10 San Felipe Road/Yerba Buena Avenue

Cycle (sec): 100 Critical Vol./Cap.(X): 0.658
Loss Time (sec): 0 Average Delay (sec/veh): 20.1
Optimal Cycle: 67 Level of Service: C+

Table with columns for Street Name, Approach, Movement, Control, Rights, Min. Green, Y+R, Lanes. Rows for San Felipe Road (North/South Bound) and Yerba Buena Avenue (East/West Bound).

Table for Volume Module showing Base Vol, Growth Adj, Initial Bse, User Adj, PHF Adj, PHF Volume, Reduct Vol, Reduced Vol, PCE Adj, MLF Adj, Final Volume.

Table for Saturation Flow Module showing Sat/Lane, Adjustment, Lanes, Final Sat.

Table for Capacity Analysis Module showing Vol/Sat, Crit Moves, Green Time, Volume/Cap, Uniform Del, IncremntDel, InitQueuDel, Delay Adj, Delay/Veh, User DelAdj, AdjDel/Veh, LOS by Move, HCM2kAvgQ.

Note: Queue reported is the number of cars per lane.

Level of Service Computation Report
2000 HCM Operations Method (Base Volume Alternative)

Intersection #11 Aborn Road/White Road/San Felipe Road

Cycle (sec): 155 Critical Vol./Cap.(X): 0.922
Loss Time (sec): 0 Average Delay (sec/veh): 54.6
Optimal Cycle: 180 Level of Service: D-

Table with columns for Street Name (San Felipe Road, Aborn Road), Approach (North Bound, South Bound, East Bound, West Bound), Movement (L, T, R), Control (Protected, Include), Rights, Min. Green, Y+R, Lanes.

Table for Volume Module showing Base Vol, Growth Adj, Initial Bse, User Adj, PHF Adj, PHF Volume, Reduct Vol, Reduced Vol, PCE Adj, MLF Adj, Final Volume for various movements.

Table for Saturation Flow Module showing Sat/Lane, Adjustment, Lanes, Final Sat. for various movements.

Table for Capacity Analysis Module showing Vol/Sat, Crit Moves, Green Time, Volume/Cap, Uniform Del, IncremntDel, InitQueuDel, Delay Adj, Delay/Veh, User DelAdj, AdjDel/Veh, LOS by Move, HCM2kAvgQ.

Note: Queue reported is the number of cars per lane.

Level of Service Computation Report
2000 HCM Operations Method (Base Volume Alternative)

Intersection #12 Aborn Road/Nieman Boulevard

Cycle (sec): 170 Critical Vol./Cap.(X): 0.746
Loss Time (sec): 0 Average Delay (sec/veh): 36.3
Optimal Cycle: 90 Level of Service: D+

Table with columns for Street Name (Nieman Boulevard, Aborn Road), Approach (North Bound, South Bound, East Bound, West Bound), Movement (L, T, R), Control (Protected, Include), Rights, Min. Green, Y+R, Lanes.

Table for Volume Module showing Base Vol, Growth Adj, Initial Bse, User Adj, PHF Adj, PHF Volume, Reduct Vol, Reduced Vol, PCE Adj, MLF Adj, Final Volume for various movements.

Table for Saturation Flow Module showing Sat/Lane, Adjustment, Lanes, Final Sat. for various movements.

Table for Capacity Analysis Module showing Vol/Sat, Crit Moves, Green Time, Volume/Cap, Uniform Del, IncremntDel, InitQueuDel, Delay Adj, Delay/Veh, User DelAdj, AdjDel/Veh, LOS by Move, HCM2kAvgQ.

Note: Queue reported is the number of cars per lane.

Level of Service Computation Report
2000 HCM Operations Method (Base Volume Alternative)

Intersection #13 Capitol Expressway/Aborn Road

Cycle (sec): 190 Critical Vol./Cap.(X): 1.553
Loss Time (sec): 0 Average Delay (sec/veh): 181.8
Optimal Cycle: 180 Level of Service: F

Table with columns for Street Name, Approach, Movement, Control, Rights, Min. Green, Y+R, Lanes. Rows for Capitol Expressway and Aborn Road.

Table with columns for Volume Module, Base Vol, Growth Adj, Initial Bse, User Adj, PHF Adj, PHF Volume, Reduct Vol, Reduced Vol, PCE Adj, MLF Adj, Final Volume.

Table with columns for Sat/Lane, Adjustment, Lanes, Final Sat. for Saturation Flow Module.

Table with columns for Vol/Sat, Crit Moves, Green Time, Volume/Cap, Uniform Del, IncremntDel, InitQueueDel, Delay Adj, Delay/Veh, User DelAdj, AdjDel/Veh, LOS by Move, HCM2kAvgQ for Capacity Analysis Module.

Note: Queue reported is the number of cars per lane.

Level of Service Computation Report
2000 HCM Operations Method (Base Volume Alternative)

Intersection #14 Capitol Expressway/Silver Creek Road

Cycle (sec): 190 Critical Vol./Cap.(X): 0.939
Loss Time (sec): 0 Average Delay (sec/veh): 55.8
Optimal Cycle: 180 Level of Service: E+

Table with columns for Street Name, Approach, Movement, Control, Rights, Min. Green, Y+R, Lanes. Rows for Capitol Expressway and Silver Creek Road.

Table with columns for Volume Module, Base Vol, Growth Adj, Initial Bse, User Adj, PHF Adj, PHF Volume, Reduct Vol, Reduced Vol, PCE Adj, MLF Adj, Final Volume.

Table with columns for Sat/Lane, Adjustment, Lanes, Final Sat. for Saturation Flow Module.

Table with columns for Vol/Sat, Crit Moves, Green Time, Volume/Cap, Uniform Del, IncremntDel, InitQueueDel, Delay Adj, Delay/Veh, User DelAdj, AdjDel/Veh, LOS by Move, HCM2kAvgQ for Capacity Analysis Module.

Note: Queue reported is the number of cars per lane.

## Scenario Report

Scenario: Cumulative PM

Command: Default Command  
 Volume: Future PM  
 Geometry: Existing  
 Impact Fee: Default Impact Fee  
 Trip Generation: Existing  
 Trip Distribution: Project  
 Paths: Project  
 Routes: Default Route  
 Configuration: Default Configuration

Impact Analysis Report  
Level Of Service

Intersection	Base		Future		Change in
	Del/	V/	Del/	V/	
	LOS Veh	C	LOS Veh	C	
# 1 U.S. 101 SB Off-ramp/Yerba Bue	F 139.5	1.282	F 139.5	1.282	+ 0.000 D/V
# 2 U.S. 101 NB Off-ramp/Yerba Bue	C 25.5	0.891	C 25.5	0.891	+ 0.000 D/V
# 3 Silver Creek Road/Yerba Buena	B- 19.6	0.728	B- 19.6	0.728	+ 0.000 D/V
# 4 Nieman Boulevard/Silver Creek	C 31.7	0.934	C 31.7	0.934	+ 0.000 D/V
# 5 Byington Drive/Yerba Buena Ave	B 13.1	0.774	B 13.1	0.774	+ 0.000 D/V
# 6 San Felipe Road/Yerba Buena Ro	E 63.0	1.075	E 63.0	1.075	+ 0.000 D/V
# 7 Paseo de Arboles/San Felipe Ro	B 13.5	0.534	B 13.5	0.534	+ 0.000 D/V
# 8 Delta Road/San Felipe Road	B 15.9	0.507	B 15.9	0.507	+ 0.000 D/V
# 9 Fowler Road/San Felipe Road	B 12.6	0.474	B 12.6	0.474	+ 0.000 D/V
# 10 San Felipe Road/Yerba Buena Av	B 13.3	0.701	B 13.3	0.701	+ 0.000 D/V
# 11 Aborn Road/White Road/San Feli	E 63.7	0.957	E 63.7	0.957	+ 0.000 D/V
# 12 Aborn Road/Nieman Boulevard	D 46.6	0.948	D 46.6	0.948	+ 0.000 D/V
# 13 Capitol Expressway/Aborn Road	F 245.7	1.868	F 245.7	1.868	+ 0.000 D/V
# 14 Capitol Expressway/Silver Cree	D- 54.7	0.945	D- 54.7	0.945	+ 0.000 D/V

Level Of Service Computation Report
2000 HCM Operations Method (Base Volume Alternative)

Intersection #1 U.S. 101 SB Off-ramp/Yerba Buena Road

Cycle (sec): 100 Critical Vol./Cap.(X): 1.282
Loss Time (sec): 0 Average Delay (sec/veh): 139.5
Optimal Cycle: 180 Level Of Service: F

Table with columns for Street Name, Approach, Movement, Control, Rights, Min. Green, Y+R, Lanes. Rows include U.S. 101 SB Off-ramp and Yerba Buena Road with North and South Bound movements.

Volume Module table showing Base Vol, Growth Adj, Initial Bse, User Adj, PHF Adj, PHF Volume, Reduct Vol, Reduced Vol, PCE Adj, MLF Adj, Final Volume for various approaches.

Saturation Flow Module table showing Sat/Lane, Adjustment, Lanes, Final Sat. for various approaches.

Capacity Analysis Module table showing Vol/Sat, Crit Moves, Green Time, Volume/Cap, Uniform Del, IncremntDel, InitQueueDel, Delay Adj, Delay/Veh, User DelAdj, AdjDel/Veh, LOS by Move, HCM2kAvgQ.

Note: Queue reported is the number of cars per lane.

Level Of Service Computation Report
2000 HCM Operations Method (Base Volume Alternative)

Intersection #2 U.S. 101 NB Off-ramp/Yerba Buena Road

Cycle (sec): 100 Critical Vol./Cap.(X): 0.891
Loss Time (sec): 0 Average Delay (sec/veh): 25.5
Optimal Cycle: 180 Level Of Service: C

Table with columns for Street Name, Approach, Movement, Control, Rights, Min. Green, Y+R, Lanes. Rows include U.S. 101 NB Off-ramp and Yerba Buena Road with North and South Bound movements.

Volume Module table showing Base Vol, Growth Adj, Initial Bse, User Adj, PHF Adj, PHF Volume, Reduct Vol, Reduced Vol, PCE Adj, MLF Adj, Final Volume for various approaches.

Saturation Flow Module table showing Sat/Lane, Adjustment, Lanes, Final Sat. for various approaches.

Capacity Analysis Module table showing Vol/Sat, Crit Moves, Green Time, Volume/Cap, Uniform Del, IncremntDel, InitQueueDel, Delay Adj, Delay/Veh, User DelAdj, AdjDel/Veh, LOS by Move, HCM2kAvgQ.

Note: Queue reported is the number of cars per lane.

Level of Service Computation Report
2000 HCM Operations Method (Base Volume Alternative)

Intersection #3 Silver Creek Road/Yerba Buena Road

Cycle (sec): 100 Critical Vol./Cap.(X): 0.728
Loss Time (sec): 0 Average Delay (sec/veh): 19.6
Optimal Cycle: 84 Level of Service: B-

Table with columns for Street Name, Approach, Movement, Control, Rights, Min. Green, Y+R, Lanes. Rows for Silver Creek Road and Yerba Buena Road.

Table with columns for Volume Module, Base Vol, Growth Adj, Initial Bse, User Adj, PHF Adj, PHF Volume, Reduct Vol, Reduced Vol, PCE Adj, MLF Adj, Final Volume.

Table with columns for Sat/Lane, Adjustment, Lanes, Final Sat. for Saturation Flow Module.

Table with columns for Vol/Sat, Crit Moves, Green Time, Volume/Cap, Uniform Del, IncremntDel, InitQueuDel, Delay Adj, Delay/Veh, User DelAdj, AdjDel/Veh, LOS by Move, HCM2kAvgQ for Capacity Analysis Module.

Note: Queue reported is the number of cars per lane.

Level of Service Computation Report
2000 HCM Operations Method (Base Volume Alternative)

Intersection #4 Nieman Boulevard/Silver Creek Valley Road/Yerba Buena Road

Cycle (sec): 100 Critical Vol./Cap.(X): 0.934
Loss Time (sec): 0 Average Delay (sec/veh): 31.7
Optimal Cycle: 180 Level of Service: C

Table with columns for Street Name, Approach, Movement, Control, Rights, Min. Green, Y+R, Lanes. Rows for Nieman Boulevard and Yerba Buena Road.

Table with columns for Volume Module, Base Vol, Growth Adj, Initial Bse, User Adj, PHF Adj, PHF Volume, Reduct Vol, Reduced Vol, PCE Adj, MLF Adj, Final Volume.

Table with columns for Sat/Lane, Adjustment, Lanes, Final Sat. for Saturation Flow Module.

Table with columns for Vol/Sat, Crit Moves, Green Time, Volume/Cap, Uniform Del, IncremntDel, InitQueuDel, Delay Adj, Delay/Veh, User DelAdj, AdjDel/Veh, LOS by Move, HCM2kAvgQ for Capacity Analysis Module.

Note: Queue reported is the number of cars per lane.

Level of Service Computation Report
2000 HCM Operations Method (Base Volume Alternative)

Intersection #5 Byington Drive/Yerba Buena Avenue/Yerba Buena Road

Cycle (sec): 100 Critical Vol./Cap.(X): 0.774
Loss Time (sec): 0 Average Delay (sec/veh): 13.1
Optimal Cycle: 101 Level of Service: B

Table with columns for Street Name, Approach, Movement, Control, Rights, Min. Green, Y+R, Lanes. Rows for Byington Drive and Yerba Buena Avenue.

Table with columns for Volume Module, Base Vol, Growth Adj, Initial Bse, User Adj, PHF Adj, PHF Volume, Reduct Vol, Reduced Vol, PCE Adj, MLF Adj, Final Volume.

Table with columns for Sat/Lane, Adjustment, Lanes, Final Sat. for Saturation Flow Module.

Table with columns for Vol/Sat, Crit Moves, Green Time, Volume/Cap, Uniform Del, IncremntDel, InitQueueDel, Delay Adj, Delay/Veh, User DelAdj, AdjDel/Veh, LOS by Move, HCM2kAvgQ for Capacity Analysis Module.

Note: Queue reported is the number of cars per lane.

Level of Service Computation Report
2000 HCM Operations Method (Base Volume Alternative)

Intersection #6 San Felipe Road/Yerba Buena Road

Cycle (sec): 120 Critical Vol./Cap.(X): 1.075
Loss Time (sec): 0 Average Delay (sec/veh): 63.0
Optimal Cycle: 180 Level of Service: E

Table with columns for Street Name, Approach, Movement, Control, Rights, Min. Green, Y+R, Lanes. Rows for San Felipe Road and Yerba Buena Road.

Table with columns for Volume Module, Base Vol, Growth Adj, Initial Bse, User Adj, PHF Adj, PHF Volume, Reduct Vol, Reduced Vol, PCE Adj, MLF Adj, Final Volume.

Table with columns for Sat/Lane, Adjustment, Lanes, Final Sat. for Saturation Flow Module.

Table with columns for Vol/Sat, Crit Moves, Green Time, Volume/Cap, Uniform Del, IncremntDel, InitQueueDel, Delay Adj, Delay/Veh, User DelAdj, AdjDel/Veh, LOS by Move, HCM2kAvgQ for Capacity Analysis Module.

Note: Queue reported is the number of cars per lane.

Level of Service Computation Report

2000 HCM Operations Method (Base Volume Alternative)

Intersection #7 Paseo de Arboles/San Felipe Road

Cycle (sec): 100 Critical Vol./Cap.(X): 0.534
Loss Time (sec): 0 Average Delay (sec/veh): 13.5
Optimal Cycle: 49 Level of Service: B

Table with columns: Street Name, Approach, Movement, Control, Rights, Min. Green, Y+R, Lanes. Rows for San Felipe Road and Paseo de Arboles.

Table with columns: Volume Module, Base Vol, Growth Adj, Initial Bse, User Adj, PHF Adj, PHF Volume, Reduct Vol, Reduced Vol, PCE Adj, MLF Adj, Final Volume.

Table with columns: Sat/Lane, Adjustment, Lanes, Final Sat. for Saturation Flow Module.

Table with columns: Vol/Sat, Crit Moves, Green Time, Volume/Cap, Uniform Del, IncremntDel, InitQueueDel, Delay Adj, Delay/Veh, User DelAdj, AdjDel/Veh, LOS by Move, HCM2kAvgQ for Capacity Analysis Module.

Note: Queue reported is the number of cars per lane.

Level of Service Computation Report

2000 HCM Operations Method (Base Volume Alternative)

Intersection #8 Delta Road/San Felipe Road

Cycle (sec): 100 Critical Vol./Cap.(X): 0.507
Loss Time (sec): 0 Average Delay (sec/veh): 15.9
Optimal Cycle: 46 Level of Service: B

Table with columns: Street Name, Approach, Movement, Control, Rights, Min. Green, Y+R, Lanes. Rows for San Felipe Road and Delta Road.

Table with columns: Volume Module, Base Vol, Growth Adj, Initial Bse, User Adj, PHF Adj, PHF Volume, Reduct Vol, Reduced Vol, PCE Adj, MLF Adj, Final Volume.

Table with columns: Sat/Lane, Adjustment, Lanes, Final Sat. for Saturation Flow Module.

Table with columns: Vol/Sat, Crit Moves, Green Time, Volume/Cap, Uniform Del, IncremntDel, InitQueueDel, Delay Adj, Delay/Veh, User DelAdj, AdjDel/Veh, LOS by Move, HCM2kAvgQ for Capacity Analysis Module.

Note: Queue reported is the number of cars per lane.



Level of Service Computation Report
2000 HCM Operations Method (Base Volume Alternative)

Intersection #9 Fowler Road/San Felipe Road

Cycle (sec): 100 Critical Vol./Cap.(X): 0.474
Loss Time (sec): 0 Average Delay (sec/veh): 12.6
Optimal Cycle: 43 Level of Service: B

Table with columns for Street Name, Approach, Movement, Control, Rights, Min. Green, Y+R, Lanes. Rows for San Felipe Road (North/South Bound) and Fowler Road (East/West Bound).

Table for Volume Module showing Base Vol, Growth Adj, Initial Bse, User Adj, PHF Adj, PHF Volume, Reduct Vol, Reduced Vol, PCE Adj, MLF Adj, Final Volume for all movements.

Table for Saturation Flow Module showing Sat/Lane, Adjustment, Lanes, Final Sat. for all movements.

Table for Capacity Analysis Module showing Vol/Sat, Crit Moves, Green Time, Volume/Cap, Uniform Del, IncremntDel, InitQueueDel, Delay Adj, Delay/Veh, User DelAdj, AdjDel/Veh, LOS by Move, HCM2kAvgQ.

Note: Queue reported is the number of cars per lane.

Level of Service Computation Report
2000 HCM Operations Method (Base Volume Alternative)

Intersection #10 San Felipe Road/Yerba Buena Avenue

Cycle (sec): 100 Critical Vol./Cap.(X): 0.701
Loss Time (sec): 0 Average Delay (sec/veh): 13.3
Optimal Cycle: 76 Level of Service: B

Table with columns for Street Name, Approach, Movement, Control, Rights, Min. Green, Y+R, Lanes. Rows for San Felipe Road (North/South Bound) and Yerba Buena Avenue (East/West Bound).

Table for Volume Module showing Base Vol, Growth Adj, Initial Bse, User Adj, PHF Adj, PHF Volume, Reduct Vol, Reduced Vol, PCE Adj, MLF Adj, Final Volume for all movements.

Table for Saturation Flow Module showing Sat/Lane, Adjustment, Lanes, Final Sat. for all movements.

Table for Capacity Analysis Module showing Vol/Sat, Crit Moves, Green Time, Volume/Cap, Uniform Del, IncremntDel, InitQueueDel, Delay Adj, Delay/Veh, User DelAdj, AdjDel/Veh, LOS by Move, HCM2kAvgQ.

Note: Queue reported is the number of cars per lane.

Level of Service Computation Report
2000 HCM Operations Method (Base Volume Alternative)

Intersection #11 Aborn Road/White Road/San Felipe Road

Cycle (sec): 155 Critical Vol./Cap.(X): 0.957
Loss Time (sec): 0 Average Delay (sec/veh): 63.7
Optimal Cycle: 180 Level of Service: E

Table with columns for Street Name (San Felipe Road, Aborn Road), Approach (North Bound, South Bound, East Bound, West Bound), Movement (L, T, R), Control (Protected, Include), Rights, Min. Green, Y+R, Lanes.

Table for Volume Module showing Base Vol, Growth Adj, Initial Bse, User Adj, PHF Adj, PHF Volume, Reduct Vol, Reduced Vol, PCE Adj, MLF Adj, Final Volume for various approaches.

Table for Saturation Flow Module showing Sat/Lane, Adjustment, Lanes, Final Sat. for various approaches.

Table for Capacity Analysis Module showing Vol/Sat, Crit Moves, Green Time, Volume/Cap, Uniform Del, IncremntDel, InitQueueDel, Delay Adj, Delay/Veh, User DelAdj, AdjDel/Veh, LOS by Move, HCM2kAvgQ.

Note: Queue reported is the number of cars per lane.

Level of Service Computation Report
2000 HCM Operations Method (Base Volume Alternative)

Intersection #12 Aborn Road/Nieman Boulevard

Cycle (sec): 170 Critical Vol./Cap.(X): 0.948
Loss Time (sec): 0 Average Delay (sec/veh): 46.6
Optimal Cycle: 180 Level of Service: D

Table with columns for Street Name (Nieman Boulevard, Aborn Road), Approach (North Bound, South Bound, East Bound, West Bound), Movement (L, T, R), Control (Protected, Include), Rights, Min. Green, Y+R, Lanes.

Table for Volume Module showing Base Vol, Growth Adj, Initial Bse, User Adj, PHF Adj, PHF Volume, Reduct Vol, Reduced Vol, PCE Adj, MLF Adj, Final Volume for various approaches.

Table for Saturation Flow Module showing Sat/Lane, Adjustment, Lanes, Final Sat. for various approaches.

Table for Capacity Analysis Module showing Vol/Sat, Crit Moves, Green Time, Volume/Cap, Uniform Del, IncremntDel, InitQueueDel, Delay Adj, Delay/Veh, User DelAdj, AdjDel/Veh, LOS by Move, HCM2kAvgQ.

Note: Queue reported is the number of cars per lane.

Level of Service Computation Report
2000 HCM Operations Method (Base Volume Alternative)

Intersection #13 Capitol Expressway/Aborn Road

Cycle (sec): 190 Critical Vol./Cap.(X): 1.868
Loss Time (sec): 0 Average Delay (sec/veh): 245.7
Optimal Cycle: 180 Level of Service: F

Table with columns for Street Name, Approach, Movement, Control, Rights, Min. Green, Y+R, Lanes. Rows for Capitol Expressway and Aborn Road.

Table with columns for Volume Module, Base Vol, Growth Adj, Initial Bse, User Adj, PHF Adj, PHF Volume, Reduct Vol, Reduced Vol, PCE Adj, MLF Adj, Final Volume.

Table with columns for Sat/Lane, Adjustment, Lanes, Final Sat. for Saturation Flow Module.

Table with columns for Vol/Sat, Crit Moves, Green Time, Volume/Cap, Uniform Del, IncremntDel, InitQueueDel, Delay Adj, Delay/Veh, User DelAdj, AdjDel/Veh, LOS by Move, HCM2kAvgQ for Capacity Analysis Module.

Note: Queue reported is the number of cars per lane.

Level of Service Computation Report
2000 HCM Operations Method (Base Volume Alternative)

Intersection #14 Capitol Expressway/Silver Creek Road

Cycle (sec): 190 Critical Vol./Cap.(X): 0.945
Loss Time (sec): 0 Average Delay (sec/veh): 54.7
Optimal Cycle: 180 Level of Service: D-

Table with columns for Street Name, Approach, Movement, Control, Rights, Min. Green, Y+R, Lanes. Rows for Capitol Expressway and Silver Creek Road.

Table with columns for Volume Module, Base Vol, Growth Adj, Initial Bse, User Adj, PHF Adj, PHF Volume, Reduct Vol, Reduced Vol, PCE Adj, MLF Adj, Final Volume.

Table with columns for Sat/Lane, Adjustment, Lanes, Final Sat. for Saturation Flow Module.

Table with columns for Vol/Sat, Crit Moves, Green Time, Volume/Cap, Uniform Del, IncremntDel, InitQueueDel, Delay Adj, Delay/Veh, User DelAdj, AdjDel/Veh, LOS by Move, HCM2kAvgQ for Capacity Analysis Module.

Note: Queue reported is the number of cars per lane.

-----  
 Scenario Report  
 Scenario: Cumulative Plus Project AM  
 -----

Command: Default Command  
 Volume: Future AM  
 Geometry: Existing  
 Impact Fee: Default Impact Fee  
 Trip Generation: Project AM  
 Trip Distribution: Project  
 Paths: Project  
 Routes: Default Route  
 Configuration: Default Configuration

-----  
 Impact Analysis Report  
 Level Of Service  
 -----

Intersection		Base		Future		Change in
		Del/	V/	Del/	V/	
		LOS	Veh	LOS	Veh	
# 1 U.S. 101 SB Off-ramp/Yerba Bue	F	92.9	1.159	F 101.8	1.189	+ 8.902 D/V
# 2 U.S. 101 NB Off-ramp/Yerba Bue	B	14.2	0.712	B 14.6	0.725	+ 0.413 D/V
# 3 Silver Creek Road/Yerba Buena	B	17.7	0.810	B- 18.3	0.817	+ 0.594 D/V
# 4 Nieman Boulevard/Silver Creek	C	28.3	0.790	C 31.1	0.878	+ 2.764 D/V
# 5 Byington Drive/Yerba Buena Ave	B+	10.2	0.645	B+ 10.7	0.681	+ 0.477 D/V
# 6 San Felipe Road/Yerba Buena Ro	E	67.2	1.081	E- 77.9	1.134	+10.705 D/V
# 7 Paseo de Arboles/San Felipe Ro	B	13.4	0.450	B 13.5	0.474	+ 0.134 D/V
# 8 Delta Road/San Felipe Road	B-	19.0	0.529	B- 18.6	0.550	-0.325 D/V
# 9 Fowler Road/San Felipe Road	B	15.3	0.447	B 14.8	0.469	-0.480 D/V
# 10 San Felipe Road/Yerba Buena Av	C+	20.1	0.658	B- 19.9	0.680	-0.214 D/V
# 11 Aborn Road/White Road/San Feli	D-	54.6	0.922	E+ 55.5	0.925	+ 0.974 D/V
# 12 Aborn Road/Nieman Boulevard	D+	36.3	0.746	D+ 38.1	0.766	+ 1.768 D/V
# 13 Capitol Expressway/Aborn Road	F	181.8	1.553	F 182.0	1.553	+ 0.144 D/V
# 14 Capitol Expressway/Silver Cree	E+	55.8	0.939	E+ 55.9	0.941	+ 0.142 D/V

Level Of Service Computation Report  
2000 HCM Operations Method (Future Volume Alternative)

\*\*\*\*\*  
Intersection #1 U.S. 101 SB Off-ramp/Yerba Buena Road  
\*\*\*\*\*

Cycle (sec): 100 Critical Vol./Cap.(X): 1.189  
Loss Time (sec): 0 Average Delay (sec/veh): 101.8  
Optimal Cycle: 180 Level Of Service: F  
\*\*\*\*\*

Street Name:	U.S. 101 SB Off-ramp						Yerba Buena Road					
Approach:	North Bound			South Bound			East Bound			West Bound		
Movement:	L	T	R	L	T	R	L	T	R	L	T	R
Control:	Protected			Protected			Protected			Protected		
Rights:	Include			Include			Include			Include		
Min. Green:	7	10	10	7	10	10	7	10	10	7	10	10
Y+R:	4.0	4.0	4.0	4.0	4.0	4.0	4.0	4.0	4.0	4.0	4.0	4.0
Lanes:	0	0	0	1	0	0	0	0	2	1	0	2

Volume Module:

Base Vol:	0	0	0	895	0	145	0	595	105	860	675	0
Growth Adj:	1.00	1.00	1.00	1.00	1.00	1.00	1.00	1.00	1.00	1.00	1.00	1.00
Initial Bse:	0	0	0	895	0	145	0	595	105	860	675	0
Added Vol:	0	0	0	43	0	0	0	5	0	6	1	0
PasserByVol:	0	0	0	0	0	0	0	0	0	0	0	0
Initial Fut:	0	0	0	938	0	145	0	600	105	866	676	0
User Adj:	1.00	1.00	1.00	1.00	1.00	1.00	1.00	1.00	1.00	1.00	1.00	1.00
PHF Adj:	1.00	1.00	1.00	1.00	1.00	1.00	1.00	1.00	1.00	1.00	1.00	1.00
PHF Volume:	0	0	0	938	0	145	0	600	105	866	676	0
Reduct Vol:	0	0	0	0	0	0	0	0	0	0	0	0
Reduced Vol:	0	0	0	938	0	145	0	600	105	866	676	0
PCE Adj:	1.00	1.00	1.00	1.00	1.00	1.00	1.00	1.00	1.00	1.00	1.00	1.00
MLF Adj:	1.00	1.00	1.00	1.00	1.00	1.00	1.00	1.00	1.00	1.00	1.00	1.00
FinalVolume:	0	0	0	938	0	145	0	600	105	866	676	0

Saturation Flow Module:

Sat/Lane:	1900	1900	1900	1900	1900	1900	1900	1900	1900	1900	1900	1900
Adjustment:	0.92	1.00	0.92	0.92	1.00	0.95	0.92	1.00	0.92	0.92	1.00	0.92
Lanes:	0.00	0.00	0.00	1.00	0.00	1.00	0.00	2.00	1.00	1.00	2.00	0.00
Final Sat.:	0	0	0	1750	0	1800	0	3800	1750	1750	3800	0

Capacity Analysis Module:

Vol/Sat:	0.00	0.00	0.00	0.54	0.00	0.08	0.00	0.16	0.06	0.49	0.18	0.00
Crit Moves:				****				****				****
Green Time:	0.0	0.0	0.0	45.1	0.0	32.4	0.0	13.3	13.3	41.6	39.4	0.0
Volume/Cap:	0.00	0.00	0.00	1.19	0.00	0.25	0.00	1.19	0.45	1.19	0.45	0.00
Uniform Del:	0.0	0.0	0.0	27.5	0.0	24.8	0.0	43.4	40.0	29.2	22.3	0.0
IncremntDel:	0.0	0.0	0.0	97.5	0.0	0.2	0.0	103	1.4	98.4	0.2	0.0
InitQueueDel:	0.0	0.0	0.0	0.0	0.0	0.0	0.0	0.0	0.0	0.0	0.0	0.0
Delay Adj:	0.00	0.00	0.00	1.00	0.00	1.00	0.00	1.00	1.00	1.00	1.00	0.00
Delay/Veh:	0.0	0.0	0.0	124.9	0.0	25.1	0.0	147	41.4	127.6	22.5	0.0
User DelAdj:	1.00	1.00	1.00	1.00	1.00	1.00	1.00	1.00	1.00	1.00	1.00	1.00
AdjDel/Veh:	0.0	0.0	0.0	124.9	0.0	25.1	0.0	147	41.4	127.6	22.5	0.0
LOS by Move:	A	A	A	F	A	C	A	F	D	F	C+	A
HCM2kAvgQ:	0	0	0	54	0	3	0	18	4	48	7	0

\*\*\*\*\*  
Note: Queue reported is the number of cars per lane.  
\*\*\*\*\*

Level Of Service Computation Report

2000 HCM Operations Method (Future Volume Alternative)

\*\*\*\*\*  
 Intersection #2 U.S. 101 NB Off-ramp/Yerba Buena Road  
 \*\*\*\*\*

Cycle (sec): 100 Critical Vol./Cap.(X): 0.725  
 Loss Time (sec): 0 Average Delay (sec/veh): 14.6  
 Optimal Cycle: 83 Level Of Service: B  
 \*\*\*\*\*

Street Name:	U.S. 101 NB Off-ram						Yerba Buena Road					
Approach:	North Bound			South Bound			East Bound			West Bound		
Movement:	L	T	R	L	T	R	L	T	R	L	T	R
Control:	Protected			Protected			Protected			Protected		
Rights:	Include			Include			Include			Include		
Min. Green:	7	10	10	7	10	10	7	10	10	7	10	10
Y+R:	4.0	4.0	4.0	4.0	4.0	4.0	4.0	4.0	4.0	4.0	4.0	4.0
Lanes:	0	0	1	0	0	1	1	0	1	1	0	1

Volume Module:

Base Vol:	0	0	0	395	0	65	165	1325	0	0	1465	855
Growth Adj:	1.00	1.00	1.00	1.00	1.00	1.00	1.00	1.00	1.00	1.00	1.00	1.00
Initial Bse:	0	0	0	395	0	65	165	1325	0	0	1465	855
Added Vol:	0	0	0	25	0	0	0	48	0	0	8	11
PasserByVol:	0	0	0	0	0	0	0	0	0	0	0	0
Initial Fut:	0	0	0	420	0	65	165	1373	0	0	1473	866
User Adj:	1.00	1.00	1.00	1.00	1.00	1.00	1.00	1.00	1.00	1.00	1.00	1.00
PHF Adj:	1.00	1.00	1.00	1.00	1.00	1.00	1.00	1.00	1.00	1.00	1.00	1.00
PHF Volume:	0	0	0	420	0	65	165	1373	0	0	1473	866
Reduct Vol:	0	0	0	0	0	0	0	0	0	0	0	0
Reduced Vol:	0	0	0	420	0	65	165	1373	0	0	1473	866
PCE Adj:	1.00	1.00	1.00	1.00	1.00	1.00	1.00	1.00	1.00	1.00	1.00	1.00
MLF Adj:	1.00	1.00	1.00	1.00	1.00	1.00	1.00	1.00	1.00	1.00	1.00	1.00
FinalVolume:	0	0	0	420	0	65	165	1373	0	0	1473	866

Saturation Flow Module:

Sat/Lane:	1900	1900	1900	1900	1900	1900	1900	1900	1900	1900	1900	1900
Adjustment:	0.92	0.92	0.92	0.92	1.00	0.92	0.92	0.97	0.92	0.92	1.00	0.92
Lanes:	0.00	1.00	0.00	1.76	0.00	0.24	1.00	2.00	0.00	1.00	2.00	1.00
Final Sat.:	0	1750	0	3086	0	414	1750	3700	0	1750	3800	1750

Capacity Analysis Module:

Vol/Sat:	0.00	0.00	0.00	0.14	0.00	0.16	0.09	0.37	0.00	0.00	0.39	0.49
Crit Moves:	****			****			****			****		
Green Time:	0.0	0.0	0.0	18.8	0.0	19.9	13.0	68.3	0.0	0.0	68.2	68.2
Volume/Cap:	0.00	0.00	0.00	0.73	0.00	0.79	0.73	0.54	0.00	0.00	0.57	0.73
Uniform Del:	0.0	0.0	0.0	38.2	0.0	38.1	41.8	8.0	0.0	0.0	8.2	10.0
IncremntDel:	0.0	0.0	0.0	4.0	0.0	6.8	11.0	0.2	0.0	0.0	0.3	2.2
InitQueueDel:	0.0	0.0	0.0	0.0	0.0	0.0	0.0	0.0	0.0	0.0	0.0	0.0
Delay Adj:	0.00	0.00	0.00	1.00	0.00	1.00	1.00	1.00	0.00	0.00	1.00	1.00
Delay/Veh:	0.0	0.0	0.0	42.2	0.0	44.9	52.8	8.2	0.0	0.0	8.5	12.2
User DelAdj:	1.00	1.00	1.00	1.00	1.00	1.00	1.00	1.00	1.00	1.00	1.00	1.00
AdjDel/Veh:	0.0	0.0	0.0	42.2	0.0	44.9	52.8	8.2	0.0	0.0	8.5	12.2
LOS by Move:	A	A	A	D	A	D	D-	A	A	A	A	B
HCM2kAvgQ:	0	0	0	9	0	11	5	10	0	0	11	17

\*\*\*\*\*  
 Note: Queue reported is the number of cars per lane.  
 \*\*\*\*\*

Level Of Service Computation Report
2000 HCM Operations Method (Future Volume Alternative)

Intersection #3 Silver Creek Road/Yerba Buena Road

Cycle (sec): 100 Critical Vol./Cap.(X): 0.817
Loss Time (sec): 0 Average Delay (sec/veh): 18.3
Optimal Cycle: 124 Level Of Service: B-

Table with columns for Street Name (Silver Creek Road, Yerba Buena Road), Approach (North Bound, South Bound, East Bound, West Bound), Movement, Control, Rights, Min. Green, Y+R, and Lanes.

Table for Volume Module showing Base Vol, Growth Adj, Initial Bse, Added Vol, PasserByVol, Initial Fut, User Adj, PHF Adj, PHF Volume, Reduct Vol, Reduced Vol, PCE Adj, MLF Adj, and Final Volume.

Table for Saturation Flow Module showing Sat/Lane, Adjustment, Lanes, and Final Sat.

Table for Capacity Analysis Module showing Vol/Sat, Crit Moves, Green Time, Volume/Cap, Uniform Del, IncremntDel, InitQueueDel, Delay Adj, Delay/Veh, User DelAdj, AdjDel/Veh, LOS by Move, and HCM2kAvgQ.

Note: Queue reported is the number of cars per lane.

Level Of Service Computation Report

2000 HCM Operations Method (Future Volume Alternative)

Intersection #4 Nieman Boulevard/Silver Creek Valley Road/Yerba Buena Road

Cycle (sec): 100 Critical Vol./Cap.(X): 0.878
Loss Time (sec): 0 Average Delay (sec/veh): 31.1
Optimal Cycle: 180 Level Of Service: C

Table with columns for Street Name (Nieman Boulevard, Yerba Buena Road), Approach (North Bound, South Bound, East Bound, West Bound), Movement (L-T-R), Control (Protected), Rights (Include), Min. Green, Y+R, and Lanes.

Table for Volume Module showing Base Vol, Growth Adj, Initial Bse, Added Vol, PasserByVol, Initial Fut, User Adj, PHF Adj, PHF Volume, Reduct Vol, Reduced Vol, PCE Adj, MLF Adj, and Final Volume.

Table for Saturation Flow Module showing Sat/Lane, Adjustment, Lanes, and Final Sat.

Table for Capacity Analysis Module showing Vol/Sat, Crit Moves, Green Time, Volume/Cap, Uniform Del, IncremntDel, InitQueueDel, Delay Adj, Delay/Veh, User DelAdj, AdjDel/Veh, LOS by Move, and HCM2kAvgQ.

Note: Queue reported is the number of cars per lane.



Level Of Service Computation Report

2000 HCM Operations Method (Future Volume Alternative)

\*\*\*\*\*  
 Intersection #5 Byington Drive/Yerba Buena Avenue/Yerba Buena Road  
 \*\*\*\*\*

Cycle (sec): 100 Critical Vol./Cap.(X): 0.681  
 Loss Time (sec): 0 Average Delay (sec/veh): 10.7  
 Optimal Cycle: 71 Level Of Service: B+  
 \*\*\*\*\*

Street Name:	Byington Drive						Yerba Buena Avenue					
Approach:	North Bound			South Bound			East Bound			West Bound		
Movement:	L	T	R	L	T	R	L	T	R	L	T	R
Control:	Protected			Protected			Protected			Protected		
Rights:	Include			Include			Include			Include		
Min. Green:	7	10	10	7	10	10	7	10	10	7	10	10
Y+R:	4.0	4.0	4.0	4.0	4.0	4.0	4.0	4.0	4.0	4.0	4.0	4.0
Lanes:	0	0	1	0	0	1	0	0	1	0	0	1

Volume Module:

Base Vol:	10	0	35	45	0	65	0	2030	5	10	2045	15
Growth Adj:	1.00	1.00	1.00	1.00	1.00	1.00	1.00	1.00	1.00	1.00	1.00	1.00
Initial Bse:	10	0	35	45	0	65	0	2030	5	10	2045	15
Added Vol:	0	0	0	0	0	0	0	136	0	0	0	35
PasserByVol:	0	0	0	0	0	0	0	0	0	0	0	0
Initial Fut:	10	0	35	45	0	65	0	2166	5	10	2080	15
User Adj:	1.00	1.00	1.00	1.00	1.00	1.00	1.00	1.00	1.00	1.00	1.00	1.00
PHF Adj:	1.00	1.00	1.00	1.00	1.00	1.00	1.00	1.00	1.00	1.00	1.00	1.00
PHF Volume:	10	0	35	45	0	65	0	2166	5	10	2080	15
Reduct Vol:	0	0	0	0	0	0	0	0	0	0	0	0
Reduced Vol:	10	0	35	45	0	65	0	2166	5	10	2080	15
PCE Adj:	1.00	1.00	1.00	1.00	1.00	1.00	1.00	1.00	1.00	1.00	1.00	1.00
MLF Adj:	1.00	1.00	1.00	1.00	1.00	1.00	1.00	1.00	1.00	1.00	1.00	1.00
FinalVolume:	10	0	35	45	0	65	0	2166	5	10	2080	15

Saturation Flow Module:

Sat/Lane:	1900	1900	1900	1900	1900	1900	1900	1900	1900	1900	1900	1900
Adjustment:	0.92	0.92	0.92	0.92	0.92	0.92	0.92	0.97	0.95	0.92	0.97	0.95
Lanes:	0.22	0.00	0.78	0.41	0.00	0.59	1.00	1.99	0.01	1.00	1.99	0.01
Final Sat.:	389	0	1361	716	0	1034	1750	3691	9	1750	3673	26

Capacity Analysis Module:

Vol/Sat:	0.03	0.00	0.03	0.06	0.00	0.06	0.00	0.59	0.59	0.01	0.57	0.57
Crit Moves:	****			****		****	****			****		
Green Time:	7.0	0.0	10.0	7.0	0.0	10.0	0.0	76.0	76.0	7.0	73.9	73.9
Volume/Cap:	0.37	0.00	0.26	0.90	0.00	0.63	0.00	0.77	0.77	0.08	0.77	0.77
Uniform Del:	44.4	0.0	41.6	46.1	0.0	43.2	0.0	7.0	7.0	43.5	7.9	7.9
IncrementDel:	1.9	0.0	0.8	51.2	0.0	7.1	0.0	1.4	1.4	0.3	1.4	1.4
InitQueueDel:	0.0	0.0	0.0	0.0	0.0	0.0	0.0	0.0	0.0	0.0	0.0	0.0
Delay Adj:	1.00	0.00	1.00	1.00	0.00	1.00	0.00	1.00	1.00	1.00	1.00	1.00
Delay/Veh:	46.3	0.0	42.4	97.3	0.0	50.3	0.0	8.3	8.3	43.8	9.2	9.2
User DelAdj:	1.00	1.00	1.00	1.00	1.00	1.00	1.00	1.00	1.00	1.00	1.00	1.00
AdjDel/Veh:	46.3	0.0	42.4	97.3	0.0	50.3	0.0	8.3	8.3	43.8	9.2	9.2
LOS by Move:	D	A	D	F	A	D	A	A	A	D	A	A
HCM2kAvgQ:	2	0	2	6	0	5	0	19	19	0	18	18

\*\*\*\*\*  
 Note: Queue reported is the number of cars per lane.  
 \*\*\*\*\*

Level of Service Computation Report  
 2000 HCM Operations Method (Future Volume Alternative)

\*\*\*\*\*  
 Intersection #6 San Felipe Road/Yerba Buena Road  
 \*\*\*\*\*

Cycle (sec): 120 Critical Vol./Cap.(X): 1.134  
 Loss Time (sec): 0 Average Delay (sec/veh): 77.9  
 Optimal Cycle: 180 Level of Service: E-  
 \*\*\*\*\*

Street Name:	San Felipe Road						Yerba Buena Road					
Approach:	North Bound			South Bound			East Bound			West Bound		
Movement:	L	T	R	L	T	R	L	T	R	L	T	R
Control:	Protected			Protected			Protected			Protected		
Rights:	Include			Include			Include			Include		
Min. Green:	7	10	10	7	10	10	7	10	10	7	10	10
Y+R:	4.0	4.0	4.0	4.0	4.0	4.0	4.0	4.0	4.0	4.0	4.0	4.0
Lanes:	2	0	2	0	1	1	1	0	2	0	1	1

Volume Module:

Base Vol:	305	460	115	310	255	545	630	1360	150	95	1190	100
Growth Adj:	1.00	1.00	1.00	1.00	1.00	1.00	1.00	1.00	1.00	1.00	1.00	1.00
Initial Bse:	305	460	115	310	255	545	630	1360	150	95	1190	100
Added Vol:	0	13	13	42	3	17	68	68	0	3	17	15
PasserByVol:	0	0	0	0	0	0	0	0	0	0	0	0
Initial Fut:	305	473	128	352	258	562	698	1428	150	98	1207	115
User Adj:	1.00	1.00	1.00	1.00	1.00	1.00	1.00	1.00	1.00	1.00	1.00	1.00
PHF Adj:	1.00	1.00	1.00	1.00	1.00	1.00	1.00	1.00	1.00	1.00	1.00	1.00
PHF Volume:	305	473	128	352	258	562	698	1428	150	98	1207	115
Reduct Vol:	0	0	0	0	0	0	0	0	0	0	0	0
Reduced Vol:	305	473	128	352	258	562	698	1428	150	98	1207	115
PCE Adj:	1.00	1.00	1.00	1.00	1.00	1.00	1.00	1.00	1.00	1.00	1.00	1.00
MLF Adj:	1.00	1.00	1.00	1.00	1.00	1.00	1.00	1.00	1.00	1.00	1.00	1.00
FinalVolume:	305	473	128	352	258	562	698	1428	150	98	1207	115

Saturation Flow Module:

Sat/Lane:	1900	1900	1900	1900	1900	1900	1900	1900	1900	1900	1900	1900
Adjustment:	0.83	1.00	0.92	0.92	1.00	0.92	0.92	1.00	0.92	0.92	1.00	0.92
Lanes:	2.00	2.00	1.00	1.00	2.00	1.00	1.00	2.00	1.00	1.00	2.00	1.00
Final Sat.:	3150	3800	1750	1750	3800	1750	1750	3800	1750	1750	3800	1750

Capacity Analysis Module:

Vol/Sat:	0.10	0.12	0.07	0.20	0.07	0.32	0.40	0.38	0.09	0.06	0.32	0.07
Crit Moves:	****					****	****			****		
Green Time:	10.2	16.9	16.9	27.3	34.0	34.0	42.2	65.6	65.6	10.2	33.6	33.6
Volume/Cap:	1.13	0.88	0.52	0.88	0.24	1.13	1.13	0.69	0.16	0.66	1.13	0.23
Uniform Del:	54.9	50.6	47.8	44.8	33.1	43.0	38.9	19.8	13.5	53.2	43.2	33.3
IncrementDel:	96.1	16.0	2.0	20.2	0.1	82.9	79.3	1.0	0.1	10.5	72.4	0.2
InitQueueDel:	0.0	0.0	0.0	0.0	0.0	0.0	0.0	0.0	0.0	0.0	0.0	0.0
Delay Adj:	1.00	1.00	1.00	1.00	1.00	1.00	1.00	1.00	1.00	1.00	1.00	1.00
Delay/Veh:	151.0	66.5	49.7	65.0	33.2	125.9	118.2	20.7	13.6	63.7	116	33.5
User DelAdj:	1.00	1.00	1.00	1.00	1.00	1.00	1.00	1.00	1.00	1.00	1.00	1.00
AdjDel/Veh:	151.0	66.5	49.7	65.0	33.2	125.9	118.2	20.7	13.6	63.7	116	33.5
LOS by Move:	F	E	D	E	C-	F	F	C+	B	E	F	C-
HCM2kAvgQ:	12	12	5	17	4	35	39	18	3	5	34	4

\*\*\*\*\*  
 Note: Queue reported is the number of cars per lane.  
 \*\*\*\*\*

Level Of Service Computation Report

2000 HCM Operations Method (Future Volume Alternative)

Intersection #7 Paseo de Arboles/San Felipe Road

Cycle (sec): 100 Critical Vol./Cap.(X): 0.474  
 Loss Time (sec): 0 Average Delay (sec/veh): 13.5  
 Optimal Cycle: 43 Level Of Service: B

Street Name:	San Felipe Road				Paseo de Arboles										
Approach:	North Bound		South Bound		East Bound		West Bound								
Movement:	L	T	R	L	T	R	L	T	R	L	T	R			
Control:	Protected		Protected		Protected		Protected								
Rights:	Include		Include		Include		Include								
Min. Green:	7	10	10	7	10	10	7	10	10	7	10	10			
Y+R:	4.0	4.0	4.0	4.0	4.0	4.0	4.0	4.0	4.0	4.0	4.0	4.0			
Lanes:	1	0	2	0	1	1	0	2	0	0	0	0	0	0	1

Volume Module:

Base Vol:	40	875	295	335	1215	0	0	0	0	25	0	50
Growth Adj:	1.00	1.00	1.00	1.00	1.00	1.00	1.00	1.00	1.00	1.00	1.00	1.00
Initial Bse:	40	875	295	335	1215	0	0	0	0	25	0	50
Added Vol:	0	10	86	40	40	0	0	0	0	22	0	10
PasserByVol:	0	0	0	0	0	0	0	0	0	0	0	0
Initial Fut:	40	885	381	375	1255	0	0	0	0	47	0	60
User Adj:	1.00	1.00	1.00	1.00	1.00	1.00	1.00	1.00	1.00	1.00	1.00	1.00
PHF Adj:	1.00	1.00	1.00	1.00	1.00	1.00	1.00	1.00	1.00	1.00	1.00	1.00
PHF Volume:	40	885	381	375	1255	0	0	0	0	47	0	60
Reduct Vol:	0	0	0	0	0	0	0	0	0	0	0	0
Reduced Vol:	40	885	381	375	1255	0	0	0	0	47	0	60
PCE Adj:	1.00	1.00	1.00	1.00	1.00	1.00	1.00	1.00	1.00	1.00	1.00	1.00
MLF Adj:	1.00	1.00	1.00	1.00	1.00	1.00	1.00	1.00	1.00	1.00	1.00	1.00
FinalVolume:	40	885	381	375	1255	0	0	0	0	47	0	60

Saturation Flow Module:

Sat/Lane:	1900	1900	1900	1900	1900	1900	1900	1900	1900	1900	1900	1900
Adjustment:	0.92	1.00	0.92	0.92	1.00	0.92	0.92	1.00	0.92	0.92	1.00	0.92
Lanes:	1.00	2.00	1.00	1.00	2.00	0.00	0.00	0.00	0.00	1.00	0.00	1.00
Final Sat.:	1750	3800	1750	1750	3800	0	0	0	0	1750	0	1750

Capacity Analysis Module:

Vol/Sat:	0.02	0.23	0.22	0.21	0.33	0.00	0.00	0.00	0.00	0.03	0.00	0.03
Crit Moves:	****			****			****			****		
Green Time:	16.3	48.4	48.4	44.6	76.7	0.0	0.0	0.0	0.0	7.0	0.0	10.0
Volume/Cap:	0.14	0.48	0.45	0.48	0.43	0.00	0.00	0.00	0.00	0.38	0.00	0.34
Uniform Del:	35.9	17.3	17.0	19.6	4.0	0.0	0.0	0.0	0.0	44.4	0.0	41.9
IncrementDel:	0.2	0.2	0.4	0.5	0.1	0.0	0.0	0.0	0.0	2.0	0.0	1.2
InitQueueDel:	0.0	0.0	0.0	0.0	0.0	0.0	0.0	0.0	0.0	0.0	0.0	0.0
Delay Adj:	1.00	1.00	1.00	1.00	1.00	0.00	0.00	0.00	0.00	1.00	0.00	1.00
Delay/Veh:	36.1	17.5	17.4	20.0	4.1	0.0	0.0	0.0	0.0	46.4	0.0	43.1
User DelAdj:	1.00	1.00	1.00	1.00	1.00	1.00	1.00	1.00	1.00	1.00	1.00	1.00
AdjDel/Veh:	36.1	17.5	17.4	20.0	4.1	0.0	0.0	0.0	0.0	46.4	0.0	43.1
LOS by Move:	D+	B	B	C+	A	A	A	A	A	D	A	D
HCM2kAvgQ:	1	9	8	8	7	0	0	0	0	2	0	2

\*\*\*\*\*  
 Note: Queue reported is the number of cars per lane.  
 \*\*\*\*\*

Level Of Service Computation Report  
 2000 HCM Operations Method (Future Volume Alternative)

\*\*\*\*\*  
 Intersection #8 Delta Road/San Felipe Road  
 \*\*\*\*\*

Cycle (sec): 100 Critical Vol./Cap.(X): 0.550  
 Loss Time (sec): 0 Average Delay (sec/veh): 18.6  
 Optimal Cycle: 51 Level Of Service: B-  
 \*\*\*\*\*

Street Name:	San Felipe Road						Delta Road					
Approach:	North Bound			South Bound			East Bound			West Bound		
Movement:	L	T	R	L	T	R	L	T	R	L	T	R
Control:	Protected			Protected			Protected			Protected		
Rights:	Include			Include			Include			Include		
Min. Green:	7	10	10	7	10	10	7	10	10	7	10	10
Y+R:	4.0	4.0	4.0	4.0	4.0	4.0	4.0	4.0	4.0	4.0	4.0	4.0
Lanes:	1	0	2	0	1	1	0	0	0	0	0	1

Volume Module:

Base Vol:	0	750	160	65	1195	0	0	0	0	375	0	215
Growth Adj:	1.00	1.00	1.00	1.00	1.00	1.00	1.00	1.00	1.00	1.00	1.00	1.00
Initial Bse:	0	750	160	65	1195	0	0	0	0	375	0	215
Added Vol:	0	20	0	0	81	0	0	0	0	0	0	0
PasserByVol:	0	0	0	0	0	0	0	0	0	0	0	0
Initial Fut:	0	770	160	65	1276	0	0	0	0	375	0	215
User Adj:	1.00	1.00	1.00	1.00	1.00	1.00	1.00	1.00	1.00	1.00	1.00	1.00
PHF Adj:	1.00	1.00	1.00	1.00	1.00	1.00	1.00	1.00	1.00	1.00	1.00	1.00
PHF Volume:	0	770	160	65	1276	0	0	0	0	375	0	215
Reduct Vol:	0	0	0	0	0	0	0	0	0	0	0	0
Reduced Vol:	0	770	160	65	1276	0	0	0	0	375	0	215
PCE Adj:	1.00	1.00	1.00	1.00	1.00	1.00	1.00	1.00	1.00	1.00	1.00	1.00
MLF Adj:	1.00	1.00	1.00	1.00	1.00	1.00	1.00	1.00	1.00	1.00	1.00	1.00
FinalVolume:	0	770	160	65	1276	0	0	0	0	375	0	215

Saturation Flow Module:

Sat/Lane:	1900	1900	1900	1900	1900	1900	1900	1900	1900	1900	1900	1900
Adjustment:	0.92	1.00	0.92	0.92	1.00	0.92	0.92	1.00	0.92	0.92	1.00	0.92
Lanes:	1.00	2.00	1.00	1.00	2.00	0.00	0.00	0.00	0.00	1.00	0.00	1.00
Final Sat.:	1750	3800	1750	1750	3800	0	0	0	0	1750	0	1750

Capacity Analysis Module:

Vol/Sat:	0.00	0.20	0.09	0.04	0.34	0.00	0.00	0.00	0.00	0.21	0.00	0.12
Crit Moves:	****			****			****			****		
Green Time:	0.0	47.4	47.4	16.4	56.8	0.0	0.0	0.0	0.0	36.2	0.0	29.4
Volume/Cap:	0.00	0.43	0.19	0.23	0.59	0.00	0.00	0.00	0.00	0.59	0.00	0.42
Uniform Del:	0.0	17.4	15.2	36.3	14.1	0.0	0.0	0.0	0.0	25.9	0.0	28.4
IncrementDel:	0.0	0.2	0.1	0.4	0.4	0.0	0.0	0.0	0.0	1.5	0.0	0.5
InitQueueDel:	0.0	0.0	0.0	0.0	0.0	0.0	0.0	0.0	0.0	0.0	0.0	0.0
Delay Adj:	0.00	1.00	1.00	1.00	1.00	0.00	0.00	0.00	0.00	1.00	0.00	1.00
Delay/Veh:	0.0	17.5	15.3	36.7	14.5	0.0	0.0	0.0	0.0	27.4	0.0	28.9
User DelAdj:	1.00	1.00	1.00	1.00	1.00	1.00	1.00	1.00	1.00	1.00	1.00	1.00
AdjDel/Veh:	0.0	17.5	15.3	36.7	14.5	0.0	0.0	0.0	0.0	27.4	0.0	28.9
LOS by Move:	A	B	B	D+	B	A	A	A	A	C	A	C
HCM2kAvgQ:	0	8	3	2	12	0	0	0	0	11	0	6

\*\*\*\*\*  
 Note: Queue reported is the number of cars per lane.  
 \*\*\*\*\*

Level Of Service Computation Report  
 2000 HCM Operations Method (Future Volume Alternative)

\*\*\*\*\*  
 Intersection #9 Fowler Road/San Felipe Road  
 \*\*\*\*\*

Cycle (sec): 100 Critical Vol./Cap.(X): 0.469  
 Loss Time (sec): 0 Average Delay (sec/veh): 14.8  
 Optimal Cycle: 43 Level Of Service: B  
 \*\*\*\*\*

Street Name:	San Felipe Road						Fowler Road					
Approach:	North Bound			South Bound			East Bound			West Bound		
Movement:	L	T	R	L	T	R	L	T	R	L	T	R
Control:	Protected			Protected			Protected			Protected		
Rights:	Include			Include			Include			Include		
Min. Green:	7	10	10	7	10	10	7	10	10	7	10	10
Y+R:	4.0	4.0	4.0	4.0	4.0	4.0	4.0	4.0	4.0	4.0	4.0	4.0
Lanes:	1	0	2	0	1	1	0	0	0	0	0	1

Volume Module:

Base Vol:	10	845	105	150	1200	0	0	0	0	105	0	220
Growth Adj:	1.00	1.00	1.00	1.00	1.00	1.00	1.00	1.00	1.00	1.00	1.00	1.00
Initial Bse:	10	845	105	150	1200	0	0	0	0	105	0	220
Added Vol:	0	20	0	0	81	0	0	0	0	0	0	0
PasserByVol:	0	0	0	0	0	0	0	0	0	0	0	0
Initial Fut:	10	865	105	150	1281	0	0	0	0	105	0	220
User Adj:	1.00	1.00	1.00	1.00	1.00	1.00	1.00	1.00	1.00	1.00	1.00	1.00
PHF Adj:	1.00	1.00	1.00	1.00	1.00	1.00	1.00	1.00	1.00	1.00	1.00	1.00
PHF Volume:	10	865	105	150	1281	0	0	0	0	105	0	220
Reduct Vol:	0	0	0	0	0	0	0	0	0	0	0	0
Reduced Vol:	10	865	105	150	1281	0	0	0	0	105	0	220
PCE Adj:	1.00	1.00	1.00	1.00	1.00	1.00	1.00	1.00	1.00	1.00	1.00	1.00
MLF Adj:	1.00	1.00	1.00	1.00	1.00	1.00	1.00	1.00	1.00	1.00	1.00	1.00
FinalVolume:	10	865	105	150	1281	0	0	0	0	105	0	220

Saturation Flow Module:

Sat/Lane:	1900	1900	1900	1900	1900	1900	1900	1900	1900	1900	1900	1900
Adjustment:	0.92	1.00	0.92	0.92	1.00	0.92	0.92	1.00	0.92	0.92	1.00	0.92
Lanes:	1.00	2.00	1.00	1.00	2.00	0.00	0.00	0.00	0.00	1.00	0.00	1.00
Final Sat.:	1750	3800	1750	1750	3800	0	0	0	0	1750	0	1750

Capacity Analysis Module:

Vol/Sat:	0.01	0.23	0.06	0.09	0.34	0.00	0.00	0.00	0.00	0.06	0.00	0.13
Crit Moves:	****			****						****		
Green Time:	7.0	54.3	54.3	20.4	67.7	0.0	0.0	0.0	0.0	13.3	0.0	25.3
Volume/Cap:	0.08	0.42	0.11	0.42	0.50	0.00	0.00	0.00	0.00	0.45	0.00	0.50
Uniform Del:	43.5	13.5	11.1	34.6	7.9	0.0	0.0	0.0	0.0	40.0	0.0	31.9
IncrementDel:	0.3	0.1	0.1	0.8	0.2	0.0	0.0	0.0	0.0	1.4	0.0	0.9
InitQueueDel:	0.0	0.0	0.0	0.0	0.0	0.0	0.0	0.0	0.0	0.0	0.0	0.0
Delay Adj:	1.00	1.00	1.00	1.00	1.00	0.00	0.00	0.00	0.00	1.00	0.00	1.00
Delay/Veh:	43.8	13.7	11.2	35.4	8.0	0.0	0.0	0.0	0.0	41.4	0.0	32.8
User DelAdj:	1.00	1.00	1.00	1.00	1.00	1.00	1.00	1.00	1.00	1.00	1.00	1.00
AdjDel/Veh:	43.8	13.7	11.2	35.4	8.0	0.0	0.0	0.0	0.0	41.4	0.0	32.8
LOS by Move:	D	B	B+	D+	A	A	A	A	A	D	A	C-
HCM2kAvgQ:	0	8	2	4	9	0	0	0	0	4	0	7

\*\*\*\*\*  
 Note: Queue reported is the number of cars per lane.  
 \*\*\*\*\*

Level Of Service Computation Report

2000 HCM Operations Method (Future Volume Alternative)

\*\*\*\*\*  
 Intersection #10 San Felipe Road/Yerba Buena Avenue  
 \*\*\*\*\*

Cycle (sec): 100 Critical Vol./Cap.(X): 0.680  
 Loss Time (sec): 0 Average Delay (sec/veh): 19.9  
 Optimal Cycle: 71 Level Of Service: B-  
 \*\*\*\*\*

Street Name:	San Felipe Road						Yerba Buena Avenue					
Approach:	North Bound			South Bound			East Bound			West Bound		
Movement:	L	T	R	L	T	R	L	T	R	L	T	R
Control:	Protected			Protected			Protected			Protected		
Rights:	Include			Include			Include			Include		
Min. Green:	7	10	10	7	10	10	7	10	10	7	10	10
Y+R:	4.0	4.0	4.0	4.0	4.0	4.0	4.0	4.0	4.0	4.0	4.0	4.0
Lanes:	1	0	2	0	0	1	1	0	0	0	0	1

Volume Module:

Base Vol:	130	970	0	0	1130	195	260	0	135	0	0	0
Growth Adj:	1.00	1.00	1.00	1.00	1.00	1.00	1.00	1.00	1.00	1.00	1.00	1.00
Initial Bse:	130	970	0	0	1130	195	260	0	135	0	0	0
Added Vol:	0	20	0	0	81	0	0	0	0	0	0	0
PasserByVol:	0	0	0	0	0	0	0	0	0	0	0	0
Initial Fut:	130	990	0	0	1211	195	260	0	135	0	0	0
User Adj:	1.00	1.00	1.00	1.00	1.00	1.00	1.00	1.00	1.00	1.00	1.00	1.00
PHF Adj:	1.00	1.00	1.00	1.00	1.00	1.00	1.00	1.00	1.00	1.00	1.00	1.00
PHF Volume:	130	990	0	0	1211	195	260	0	135	0	0	0
Reduct Vol:	0	0	0	0	0	0	0	0	0	0	0	0
Reduced Vol:	130	990	0	0	1211	195	260	0	135	0	0	0
PCE Adj:	1.00	1.00	1.00	1.00	1.00	1.00	1.00	1.00	1.00	1.00	1.00	1.00
MLF Adj:	1.00	1.00	1.00	1.00	1.00	1.00	1.00	1.00	1.00	1.00	1.00	1.00
FinalVolume:	130	990	0	0	1211	195	260	0	135	0	0	0

Saturation Flow Module:

Sat/Lane:	1900	1900	1900	1900	1900	1900	1900	1900	1900	1900	1900	1900
Adjustment:	0.92	1.00	0.92	0.92	0.98	0.95	0.92	0.92	0.92	0.92	1.00	0.92
Lanes:	1.00	2.00	0.00	0.00	1.71	0.29	0.66	0.00	0.34	0.00	0.00	0.00
Final Sat.:	1750	3800	0	0	3186	513	1152	0	598	0	0	0

Capacity Analysis Module:

Vol/Sat:	0.07	0.26	0.00	0.00	0.38	0.38	0.23	0.00	0.23	0.00	0.00	0.00
Crit Moves:	****			****			****					
Green Time:	10.9	52.7	0.0	0.0	55.9	55.9	33.2	0.0	33.0	0.0	0.0	0.0
Volume/Cap:	0.68	0.49	0.00	0.00	0.68	0.68	0.68	0.00	0.68	0.00	0.00	0.00
Uniform Del:	42.9	15.2	0.0	0.0	15.7	15.7	28.8	0.0	29.0	0.0	0.0	0.0
IncrementDel:	9.5	0.2	0.0	0.0	0.9	0.9	3.3	0.0	3.4	0.0	0.0	0.0
InitQueueDel:	0.0	0.0	0.0	0.0	0.0	0.0	0.0	0.0	0.0	0.0	0.0	0.0
Delay Adj:	1.00	1.00	0.00	0.00	1.00	1.00	1.00	0.00	1.00	0.00	0.00	0.00
Delay/Veh:	52.4	15.3	0.0	0.0	16.6	16.6	32.1	0.0	32.4	0.0	0.0	0.0
User DelAdj:	1.00	1.00	1.00	1.00	1.00	1.00	1.00	1.00	1.00	1.00	1.00	1.00
AdjDel/Veh:	52.4	15.3	0.0	0.0	16.6	16.6	32.1	0.0	32.4	0.0	0.0	0.0
LOS by Move:	D-	B	A	A	B	B	C-	A	C-	A	A	A
HCM2kAvgQ:	4	9	0	0	16	16	12	0	12	0	0	0

\*\*\*\*\*  
 Note: Queue reported is the number of cars per lane.  
 \*\*\*\*\*

Level Of Service Computation Report  
 2000 HCM Operations Method (Future Volume Alternative)

\*\*\*\*\*  
 Intersection #11 Aborn Road/White Road/San Felipe Road  
 \*\*\*\*\*

Cycle (sec): 155 Critical Vol./Cap.(X): 0.925  
 Loss Time (sec): 0 Average Delay (sec/veh): 55.5  
 Optimal Cycle: 180 Level Of Service: E+

Street Name:	San Felipe Road						Aborn Road					
Approach:	North Bound			South Bound			East Bound			West Bound		
Movement:	L	T	R	L	T	R	L	T	R	L	T	R
Control:	Protected			Protected			Protected			Protected		
Rights:	Include			Include			Include			Include		
Min. Green:	7	10	10	7	10	10	7	10	10	7	10	10
Y+R:	4.0	4.0	4.0	4.0	4.0	4.0	4.0	4.0	4.0	4.0	4.0	4.0
Lanes:	2	0	2	0	1	1	2	0	2	0	1	1

Volume Module:

Base Vol:	475	655	110	235	695	550	400	1645	510	165	1880	255
Growth Adj:	1.00	1.00	1.00	1.00	1.00	1.00	1.00	1.00	1.00	1.00	1.00	1.00
Initial Bse:	475	655	110	235	695	550	400	1645	510	165	1880	255
Added Vol:	10	6	4	0	25	0	0	0	40	15	0	0
PasserByVol:	0	0	0	0	0	0	0	0	0	0	0	0
Initial Fut:	485	661	114	235	720	550	400	1645	550	180	1880	255
User Adj:	1.00	1.00	1.00	1.00	1.00	1.00	1.00	1.00	1.00	1.00	1.00	1.00
PHF Adj:	1.00	1.00	1.00	1.00	1.00	1.00	1.00	1.00	1.00	1.00	1.00	1.00
PHF Volume:	485	661	114	235	720	550	400	1645	550	180	1880	255
Reduct Vol:	0	0	0	0	0	0	0	0	0	0	0	0
Reduced Vol:	485	661	114	235	720	550	400	1645	550	180	1880	255
PCE Adj:	1.00	1.00	1.00	1.00	1.00	1.00	1.00	1.00	1.00	1.00	1.00	1.00
MLF Adj:	1.00	1.00	1.00	1.00	1.00	1.00	1.00	1.00	1.00	1.00	1.00	1.00
FinalVolume:	485	661	114	235	720	550	400	1645	550	180	1880	255

Saturation Flow Module:

Sat/Lane:	1900	1900	1900	1900	1900	1900	1900	1900	1900	1900	1900	1900
Adjustment:	0.83	1.00	0.92	0.83	1.00	0.92	0.83	1.00	0.92	0.92	1.00	0.92
Lanes:	2.00	2.00	1.00	2.00	2.00	1.00	2.00	3.00	1.00	1.00	3.00	1.00
Final Sat.:	3150	3800	1750	3150	3800	1750	3150	5700	1750	1750	5700	1750

Capacity Analysis Module:

Vol/Sat:	0.15	0.17	0.07	0.07	0.19	0.31	0.13	0.29	0.31	0.10	0.33	0.15
Crit Moves:	****					****	****			****		
Green Time:	25.8	54.9	54.9	23.5	52.7	52.7	21.3	57.7	57.7	18.9	55.3	55.3
Volume/Cap:	0.93	0.49	0.18	0.49	0.56	0.93	0.93	0.78	0.84	0.84	0.93	0.41
Uniform Del:	63.6	39.1	34.6	60.2	41.7	49.3	66.1	43.0	44.6	66.6	47.9	37.6
IncrementDel:	22.4	0.3	0.1	0.8	0.5	20.5	25.7	1.9	9.9	25.3	7.8	0.4
InitQueueDel:	0.0	0.0	0.0	0.0	0.0	0.0	0.0	0.0	0.0	0.0	0.0	0.0
Delay Adj:	1.00	1.00	1.00	1.00	1.00	1.00	1.00	1.00	1.00	1.00	1.00	1.00
Delay/Veh:	86.1	39.4	34.7	61.0	42.2	69.7	91.7	44.8	54.5	92.0	55.7	38.0
User DelAdj:	1.00	1.00	1.00	1.00	1.00	1.00	1.00	1.00	1.00	1.00	1.00	1.00
AdjDel/Veh:	86.1	39.4	34.7	61.0	42.2	69.7	91.7	44.8	54.5	92.0	55.7	38.0
LOS by Move:	F	D	C-	E	D	E	F	D	D-	F	E+	D+
HCM2kAvgQ:	15	12	4	7	14	31	12	22	26	11	32	10

\*\*\*\*\*  
 Note: Queue reported is the number of cars per lane.  
 \*\*\*\*\*

Level Of Service Computation Report

2000 HCM Operations Method (Future Volume Alternative)

\*\*\*\*\*  
 Intersection #12 Aborn Road/Nieman Boulevard  
 \*\*\*\*\*

Cycle (sec): 170 Critical Vol./Cap.(X): 0.766  
 Loss Time (sec): 0 Average Delay (sec/veh): 38.1  
 Optimal Cycle: 98 Level Of Service: D+

Street Name:	Nieman Boulevard						Aborn Road								
Approach:	North Bound			South Bound			East Bound			West Bound					
Movement:	L	T	R	L	T	R	L	T	R	L	T	R			
Control:	Protected			Protected			Protected			Protected					
Rights:	Include			Include			Include			Include					
Min. Green:	7	10	10	7	10	10	7	10	10	7	10	10			
Y+R:	4.0	4.0	4.0	4.0	4.0	4.0	4.0	4.0	4.0	4.0	4.0	4.0			
Lanes:	1	0	2	0	1	1	0	2	0	1	1	0	2	1	0

Volume Module:

Base Vol:	135	290	155	290	140	130	20	2170	55	165	2365	535
Growth Adj:	1.00	1.00	1.00	1.00	1.00	1.00	1.00	1.00	1.00	1.00	1.00	1.00
Initial Bse:	135	290	155	290	140	130	20	2170	55	165	2365	535
Added Vol:	0	3	0	34	11	0	0	6	0	0	2	9
PasserByVol:	0	0	0	0	0	0	0	0	0	0	0	0
Initial Fut:	135	293	155	324	151	130	20	2176	55	165	2367	544
User Adj:	1.00	1.00	1.00	1.00	1.00	1.00	1.00	1.00	1.00	1.00	1.00	1.00
PHF Adj:	1.00	1.00	1.00	1.00	1.00	1.00	1.00	1.00	1.00	1.00	1.00	1.00
PHF Volume:	135	293	155	324	151	130	20	2176	55	165	2367	544
Reduct Vol:	0	0	0	0	0	0	0	0	0	0	0	0
Reduced Vol:	135	293	155	324	151	130	20	2176	55	165	2367	544
PCE Adj:	1.00	1.00	1.00	1.00	1.00	1.00	1.00	1.00	1.00	1.00	1.00	1.00
MLF Adj:	1.00	1.00	1.00	1.00	1.00	1.00	1.00	1.00	1.00	1.00	1.00	1.00
FinalVolume:	135	293	155	324	151	130	20	2176	55	165	2367	544

Saturation Flow Module:

Sat/Lane:	1900	1900	1900	1900	1900	1900	1900	1900	1900	1900	1900	1900
Adjustment:	0.92	1.00	0.92	0.92	1.00	0.92	0.92	0.98	0.95	0.92	1.00	0.92
Lanes:	1.00	2.00	1.00	1.00	2.00	1.00	1.00	2.92	0.08	1.00	3.00	1.00
Final Sat.:	1750	3800	1750	1750	3800	1750	1750	5462	138	1750	5700	1750

Capacity Analysis Module:

Vol/Sat:	0.08	0.08	0.09	0.19	0.04	0.07	0.01	0.40	0.40	0.09	0.42	0.31
Crit Moves:	****	****	****	****	****	****	****	****	****	****	****	****
Green Time:	30.9	19.6	19.6	41.1	29.8	29.8	9.9	88.4	88.4	20.9	99.4	99.4
Volume/Cap:	0.42	0.67	0.77	0.77	0.23	0.42	0.20	0.77	0.77	0.77	0.71	0.53
Uniform Del:	61.6	72.0	73.0	60.0	60.2	62.5	76.3	32.6	32.6	72.2	25.1	21.3
IncrementDel:	0.9	3.9	16.0	8.2	0.2	0.9	1.0	1.3	1.3	15.2	0.7	0.5
InitQueueDel:	0.0	0.0	0.0	0.0	0.0	0.0	0.0	0.0	0.0	0.0	0.0	0.0
Delay Adj:	1.00	1.00	1.00	1.00	1.00	1.00	1.00	1.00	1.00	1.00	1.00	1.00
Delay/Veh:	62.6	75.9	89.0	68.2	60.4	63.4	77.3	33.8	33.8	87.4	25.8	21.8
User DelAdj:	1.00	1.00	1.00	1.00	1.00	1.00	1.00	1.00	1.00	1.00	1.00	1.00
AdjDel/Veh:	62.6	75.9	89.0	68.2	60.4	63.4	77.3	33.8	33.8	87.4	25.8	21.8
LOS by Move:	E	E-	F	E	E	E	E-	C-	C-	F	C	C+
HCM2kAvgQ:	7	8	10	18	3	7	1	29	29	9	27	17

\*\*\*\*\*  
 Note: Queue reported is the number of cars per lane.  
 \*\*\*\*\*



Level Of Service Computation Report

2000 HCM Operations Method (Future Volume Alternative)

\*\*\*\*\*  
 Intersection #13 Capitol Expressway/Aborn Road  
 \*\*\*\*\*

Cycle (sec): 190 Critical Vol./Cap.(X): 1.553  
 Loss Time (sec): 0 Average Delay (sec/veh): 182.0  
 Optimal Cycle: 180 Level Of Service: F  
 \*\*\*\*\*

Street Name:	Capitol Expresswa						Aborn Road									
Approach:	North Bound			South Bound			East Bound			West Bound						
Movement:	L	T	R	L	T	R	L	T	R	L	T	R				
Control:	Protected			Protected			Protected			Protected						
Rights:	Include			Include			Include			Include						
Min. Green:	7	10	10	7	10	10	7	10	10	7	10	10				
Y+R:	4.0	4.0	4.0	4.0	4.0	4.0	4.0	4.0	4.0	4.0	4.0	4.0				
Lanes:	1	0	4	0	1	2	0	3	1	0	1	2	0	2	0	1

Volume Module:

Base Vol:	180	1675	1255	900	1210	45	120	210	130	1500	660	670
Growth Adj:	1.00	1.00	1.00	1.00	1.00	1.00	1.00	1.00	1.00	1.00	1.00	1.00
Initial Bse:	180	1675	1255	900	1210	45	120	210	130	1500	660	670
Added Vol:	0	0	0	0	0	0	0	6	0	0	2	0
PasserByVol:	0	0	0	0	0	0	0	0	0	0	0	0
Initial Fut:	180	1675	1255	900	1210	45	120	216	130	1500	662	670
User Adj:	1.00	1.00	1.00	1.00	1.00	1.00	1.00	1.00	1.00	1.00	1.00	1.00
PHF Adj:	1.00	1.00	1.00	1.00	1.00	1.00	1.00	1.00	1.00	1.00	1.00	1.00
PHF Volume:	180	1675	1255	900	1210	45	120	216	130	1500	662	670
Reduct Vol:	0	0	0	0	0	0	0	0	0	0	0	0
Reduced Vol:	180	1675	1255	900	1210	45	120	216	130	1500	662	670
PCE Adj:	1.00	1.00	1.00	1.00	1.00	1.00	1.00	1.00	1.00	1.00	1.00	1.00
MLF Adj:	1.00	1.00	1.00	1.00	1.00	1.00	1.00	1.00	1.00	1.00	1.00	1.00
FinalVolume:	180	1675	1255	900	1210	45	120	216	130	1500	662	670

Saturation Flow Module:

Sat/Lane:	1900	1900	1900	1900	1900	1900	1900	1900	1900	1900	1900	1900
Adjustment:	0.92	1.00	0.92	0.83	0.99	0.95	0.92	1.00	0.92	0.83	1.00	0.92
Lanes:	1.00	4.00	1.00	2.00	3.85	0.15	1.00	2.00	1.00	2.00	2.00	1.00
Final Sat.:	1750	7600	1750	3150	7231	269	1750	3800	1750	3150	3800	1750

Capacity Analysis Module:

Vol/Sat:	0.10	0.22	0.72	0.29	0.17	0.17	0.07	0.06	0.07	0.48	0.17	0.38
Crit Moves:	****	****	****	****	****	****	****	****	****	****	****	****
Green Time:	46.3	87.0	87.0	34.7	75.4	75.4	10.4	10.6	10.6	57.8	57.9	57.9
Volume/Cap:	0.42	0.48	1.57	1.57	0.42	0.42	1.26	1.02	1.34	1.57	0.57	1.26
Uniform Del:	57.4	33.9	48.8	73.6	39.4	39.4	85.1	85.0	85.0	62.6	52.6	62.6
IncrementDel:	0.7	0.1	260.8	263.1	0.1	0.1	175.5	68.1	205.8	259.8	0.7	129.6
InitQueueDel:	0.0	0.0	0.0	0.0	0.0	0.0	0.0	0.0	0.0	0.0	0.0	0.0
Delay Adj:	1.00	1.00	1.00	1.00	1.00	1.00	1.00	1.00	1.00	1.00	1.00	1.00
Delay/Veh:	58.0	34.0	309.6	336.7	39.5	39.5	260.6	153	290.8	322.5	53.3	192.1
User DelAdj:	1.00	1.00	1.00	1.00	1.00	1.00	1.00	1.00	1.00	1.00	1.00	1.00
AdjDel/Veh:	58.0	34.0	309.6	336.7	39.5	39.5	260.6	153	290.8	322.5	53.3	192.1
LOS by Move:	E+	C-	F	F	D	D	F	F	F	F	D-	F
HCM2kAvgQ:	9	15	131	54	12	12	13	9	14	87	15	57

\*\*\*\*\*  
 Note: Queue reported is the number of cars per lane.  
 \*\*\*\*\*

Level Of Service Computation Report  
 2000 HCM Operations Method (Future Volume Alternative)

\*\*\*\*\*  
 Intersection #14 Capitol Expressway/Silver Creek Road  
 \*\*\*\*\*

Cycle (sec): 190 Critical Vol./Cap.(X): 0.941  
 Loss Time (sec): 0 Average Delay (sec/veh): 55.9  
 Optimal Cycle: 180 Level Of Service: E+

Street Name:	Capitol Expresswa						Silver Creek Road					
Approach:	North Bound			South Bound			East Bound			West Bound		
Movement:	L	T	R	L	T	R	L	T	R	L	T	R
Control:	Protected			Protected			Protected			Protected		
Rights:	Include			Include			Include			Include		
Min. Green:	7	10	10	7	10	10	7	10	10	7	10	10
Y+R:	4.0	4.0	4.0	4.0	4.0	4.0	4.0	4.0	4.0	4.0	4.0	4.0
Lanes:	2	0	4	0	1	1	2	0	4	0	1	1

Volume Module:

Base Vol:	545	2705	330	125	2735	15	35	355	355	640	505	165
Growth Adj:	1.00	1.00	1.00	1.00	1.00	1.00	1.00	1.00	1.00	1.00	1.00	1.00
Initial Bse:	545	2705	330	125	2735	15	35	355	355	640	505	165
Added Vol:	0	0	20	0	0	0	0	6	0	5	2	0
PasserByVol:	0	0	0	0	0	0	0	0	0	0	0	0
Initial Fut:	545	2705	350	125	2735	15	35	361	355	645	507	165
User Adj:	1.00	1.00	1.00	1.00	1.00	1.00	1.00	1.00	1.00	1.00	1.00	1.00
PHF Adj:	1.00	1.00	1.00	1.00	1.00	1.00	1.00	1.00	1.00	1.00	1.00	1.00
PHF Volume:	545	2705	350	125	2735	15	35	361	355	645	507	165
Reduct Vol:	0	0	0	0	0	0	0	0	0	0	0	0
Reduced Vol:	545	2705	350	125	2735	15	35	361	355	645	507	165
PCE Adj:	1.00	1.00	1.00	1.00	1.00	1.00	1.00	1.00	1.00	1.00	1.00	1.00
MLF Adj:	1.00	1.00	1.00	1.00	1.00	1.00	1.00	1.00	1.00	1.00	1.00	1.00
FinalVolume:	545	2705	350	125	2735	15	35	361	355	645	507	165

Saturation Flow Module:

Sat/Lane:	1900	1900	1900	1900	1900	1900	1900	1900	1900	1900	1900	1900
Adjustment:	0.83	1.00	0.92	0.83	1.00	0.92	0.83	1.00	0.92	0.83	0.98	0.95
Lanes:	2.00	4.00	1.00	2.00	4.00	1.00	2.00	2.00	1.00	2.00	1.50	0.50
Final Sat.:	3150	7600	1750	3150	7600	1750	3150	3800	1750	3150	2791	908

Capacity Analysis Module:

Vol/Sat:	0.17	0.36	0.20	0.04	0.36	0.01	0.01	0.10	0.20	0.20	0.18	0.18
Crit Moves:	****			****			****		****	****		
Green Time:	35.0	96.9	96.9	10.8	72.7	72.7	14.5	41.0	41.0	41.4	67.8	67.8
Volume/Cap:	0.94	0.70	0.39	0.70	0.94	0.02	0.15	0.44	0.94	0.94	0.51	0.51
Uniform Del:	72.5	33.6	27.0	83.4	53.6	34.6	77.6	61.2	69.5	69.3	45.5	45.5
IncrementDel:	23.6	0.6	0.3	11.5	7.0	0.0	0.3	0.2	19.5	21.0	0.3	0.3
InitQueueDel:	0.0	0.0	0.0	0.0	0.0	0.0	0.0	0.0	0.0	0.0	0.0	0.0
Delay Adj:	1.00	1.00	1.00	1.00	1.00	1.00	1.00	1.00	1.00	1.00	1.00	1.00
Delay/Veh:	96.1	34.2	27.3	94.9	60.6	34.6	77.9	61.4	89.0	90.3	45.8	45.8
User DelAdj:	1.00	1.00	1.00	1.00	1.00	1.00	1.00	1.00	1.00	1.00	1.00	1.00
AdjDel/Veh:	96.1	34.2	27.3	94.9	60.6	34.6	77.9	61.4	89.0	90.3	45.8	45.8
LOS by Move:	F	C-	C	F	E	C-	E-	E	F	F	D	D
HCM2kAvgQ:	21	28	12	4	39	1	1	9	25	25	15	15

\*\*\*\*\*  
 Note: Queue reported is the number of cars per lane.  
 \*\*\*\*\*

Scenario Report

Scenario: Cumulative Plus Project AM Mitigated

Command: Default Command  
 Volume: Future AM  
 Geometry: Existing  
 Impact Fee: Default Impact Fee  
 Trip Generation: Project AM  
 Trip Distribution: Project  
 Paths: Project  
 Routes: Default Route  
 Configuration: Default Configuration

Impact Analysis Report  
 Level Of Service

Intersection	Base		Future		Change in
	Del/ LOS	V/ Veh	Del/ LOS	V/ Veh	
# 6 San Felipe Road/Yerba Buena Ro	D	45.8 0.921	D	49.6 0.957	+ 3.841 D/V
# 11 Aborn Road/White Road/San Feli	D-	52.3 0.922	D-	53.0 0.925	+ 0.616 D/V

Level Of Service Computation Report

2000 HCM Operations Method (Future Volume Alternative)

\*\*\*\*\*  
 Intersection #6 San Felipe Road/Yerba Buena Road  
 \*\*\*\*\*  
 Cycle (sec): 120 Critical Vol./Cap.(X): 0.957  
 Loss Time (sec): 0 Average Delay (sec/veh): 49.6  
 Optimal Cycle: 180 Level Of Service: D  
 \*\*\*\*\*

Street Name:	San Felipe Road						Yerba Buena Road					
Approach:	North Bound			South Bound			East Bound			West Bound		
Movement:	L	T	R	L	T	R	L	T	R	L	T	R
Control:	Protected			Protected			Protected			Protected		
Rights:	Include			Include			Include			Include		
Min. Green:	7	10	10	7	10	10	7	10	10	7	10	10
Y+R:	4.0	4.0	4.0	4.0	4.0	4.0	4.0	4.0	4.0	4.0	4.0	4.0
Lanes:	2	0	2	0	1	1	2	0	2	0	1	1

Volume Module:

Base Vol:	305	460	115	310	255	545	630	1360	150	95	1190	100
Growth Adj:	1.00	1.00	1.00	1.00	1.00	1.00	1.00	1.00	1.00	1.00	1.00	1.00
Initial Bse:	305	460	115	310	255	545	630	1360	150	95	1190	100
Added Vol:	0	13	13	42	3	17	68	68	0	3	17	15
PasserByVol:	0	0	0	0	0	0	0	0	0	0	0	0
Initial Fut:	305	473	128	352	258	562	698	1428	150	98	1207	115
User Adj:	1.00	1.00	1.00	1.00	1.00	1.00	1.00	1.00	1.00	1.00	1.00	1.00
PHF Adj:	1.00	1.00	1.00	1.00	1.00	1.00	1.00	1.00	1.00	1.00	1.00	1.00
PHF Volume:	305	473	128	352	258	562	698	1428	150	98	1207	115
Reduct Vol:	0	0	0	0	0	0	0	0	0	0	0	0
Reduced Vol:	305	473	128	352	258	562	698	1428	150	98	1207	115
PCE Adj:	1.00	1.00	1.00	1.00	1.00	1.00	1.00	1.00	1.00	1.00	1.00	1.00
MLF Adj:	1.00	1.00	1.00	1.00	1.00	1.00	1.00	1.00	1.00	1.00	1.00	1.00
FinalVolume:	305	473	128	352	258	562	698	1428	150	98	1207	115

Saturation Flow Module:

Sat/Lane:	1900	1900	1900	1900	1900	1900	1900	1900	1900	1900	1900	1900
Adjustment:	0.83	1.00	0.92	0.92	1.00	0.92	0.83	1.00	0.92	0.92	1.00	0.92
Lanes:	2.00	2.00	1.00	1.00	2.00	1.00	2.00	2.00	1.00	1.00	2.00	1.00
Final Sat.:	3150	3800	1750	1750	3800	1750	3150	3800	1750	1750	3800	1750

Capacity Analysis Module:

Vol/Sat:	0.10	0.12	0.07	0.20	0.07	0.32	0.22	0.38	0.09	0.06	0.32	0.07
Crit Moves:	****			****			****			****		
Green Time:	12.1	20.0	20.0	32.4	40.3	40.3	27.8	58.5	58.5	9.1	39.8	39.8
Volume/Cap:	0.96	0.75	0.44	0.75	0.20	0.96	0.96	0.77	0.18	0.74	0.96	0.20
Uniform Del:	53.7	47.6	44.9	40.1	28.4	39.0	45.5	25.2	17.2	54.3	39.3	28.7
IncrementDel:	38.9	4.8	1.1	6.4	0.1	26.7	23.3	2.0	0.1	19.7	16.2	0.2
InitQueueDel:	0.0	0.0	0.0	0.0	0.0	0.0	0.0	0.0	0.0	0.0	0.0	0.0
Delay Adj:	1.00	1.00	1.00	1.00	1.00	1.00	1.00	1.00	1.00	1.00	1.00	1.00
Delay/Veh:	92.6	52.4	46.0	46.4	28.5	65.8	68.8	27.3	17.3	74.0	55.4	28.8
User DelAdj:	1.00	1.00	1.00	1.00	1.00	1.00	1.00	1.00	1.00	1.00	1.00	1.00
AdjDel/Veh:	92.6	52.4	46.0	46.4	28.5	65.8	68.8	27.3	17.3	74.0	55.4	28.8
LOS by Move:	F	D-	D	D	C	E	E	C	B	E	E+	C
HCM2kAvgQ:	10	10	5	14	3	27	17	21	3	5	27	3

\*\*\*\*\*  
 Note: Queue reported is the number of cars per lane.  
 \*\*\*\*\*

Level Of Service Computation Report

2000 HCM Operations Method (Future Volume Alternative)

\*\*\*\*\*  
 Intersection #11 Aborn Road/White Road/San Felipe Road  
 \*\*\*\*\*  
 Cycle (sec): 155 Critical Vol./Cap.(X): 0.925  
 Loss Time (sec): 0 Average Delay (sec/veh): 53.0  
 Optimal Cycle: 180 Level Of Service: D-  
 \*\*\*\*\*

Street Name:	San Felipe Road						Aborn Road					
Approach:	North Bound			South Bound			East Bound			West Bound		
Movement:	L	T	R	L	T	R	L	T	R	L	T	R
Control:	Protected			Protected			Protected			Protected		
Rights:	Include			Include			Include			Include		
Min. Green:	7	10	10	7	10	10	7	10	10	7	10	10
Y+R:	4.0	4.0	4.0	4.0	4.0	4.0	4.0	4.0	4.0	4.0	4.0	4.0
Lanes:	2	0	2	0	1	1	2	0	3	0	1	1

Volume Module:

Base Vol:	475	655	110	235	695	550	400	1645	510	165	1880	255
Growth Adj:	1.00	1.00	1.00	1.00	1.00	1.00	1.00	1.00	1.00	1.00	1.00	1.00
Initial Bse:	475	655	110	235	695	550	400	1645	510	165	1880	255
Added Vol:	10	6	4	0	25	0	0	0	40	15	0	0
PasserByVol:	0	0	0	0	0	0	0	0	0	0	0	0
Initial Fut:	485	661	114	235	720	550	400	1645	550	180	1880	255
User Adj:	1.00	1.00	1.00	1.00	1.00	1.00	1.00	1.00	1.00	1.00	1.00	1.00
PHF Adj:	1.00	1.00	1.00	1.00	1.00	1.00	1.00	1.00	1.00	1.00	1.00	1.00
PHF Volume:	485	661	114	235	720	550	400	1645	550	180	1880	255
Reduct Vol:	0	0	0	0	0	0	0	0	0	0	0	0
Reduced Vol:	485	661	114	235	720	550	400	1645	550	180	1880	255
PCE Adj:	1.00	1.00	1.00	1.00	1.00	1.00	1.00	1.00	1.00	1.00	1.00	1.00
MLF Adj:	1.00	1.00	1.00	1.00	1.00	1.00	1.00	1.00	1.00	1.00	1.00	1.00
FinalVolume:	485	661	114	235	720	550	400	1645	550	180	1880	255

Saturation Flow Module:

Sat/Lane:	1900	1900	1900	1900	1900	1900	1900	1900	1900	1900	1900	1900
Adjustment:	0.83	1.00	0.92	0.83	1.00	0.92	0.83	1.00	0.92	0.83	1.00	0.92
Lanes:	2.00	2.00	1.00	2.00	2.00	1.00	2.00	3.00	1.00	2.00	3.00	1.00
Final Sat.:	3150	3800	1750	3150	3800	1750	3150	5700	1750	3150	5700	1750

Capacity Analysis Module:

Vol/Sat:	0.15	0.17	0.07	0.07	0.19	0.31	0.13	0.29	0.31	0.06	0.33	0.15
Crit Moves:	****					****	****			****		
Green Time:	25.8	54.9	54.9	23.5	52.7	52.7	21.3	64.8	64.8	11.8	55.3	55.3
Volume/Cap:	0.93	0.49	0.18	0.49	0.56	0.93	0.93	0.69	0.75	0.75	0.93	0.41
Uniform Del:	63.6	39.1	34.6	60.2	41.7	49.3	66.1	36.9	38.3	70.2	47.9	37.6
IncrcmntDel:	22.4	0.3	0.1	0.8	0.5	20.5	25.7	0.9	4.4	12.6	7.8	0.4
InitQueuDel:	0.0	0.0	0.0	0.0	0.0	0.0	0.0	0.0	0.0	0.0	0.0	0.0
Delay Adj:	1.00	1.00	1.00	1.00	1.00	1.00	1.00	1.00	1.00	1.00	1.00	1.00
Delay/Veh:	86.1	39.4	34.7	61.0	42.2	69.7	91.7	37.8	42.7	82.8	55.7	38.0
User DelAdj:	1.00	1.00	1.00	1.00	1.00	1.00	1.00	1.00	1.00	1.00	1.00	1.00
AdjDel/Veh:	86.1	39.4	34.7	61.0	42.2	69.7	91.7	37.8	42.7	82.8	55.7	38.0
LOS by Move:	F	D	C-	E	D	E	F	D+	D	F	E+	D+
HCM2kAvgQ:	15	12	4	7	14	31	12	20	23	7	32	10

\*\*\*\*\*  
 Note: Queue reported is the number of cars per lane.  
 \*\*\*\*\*

-----  
 Scenario Report  
 Scenario: Cumulative Plus Project PM  
 -----

Command: Default Command  
 Volume: Future PM  
 Geometry: Existing  
 Impact Fee: Default Impact Fee  
 Trip Generation: Project PM  
 Trip Distribution: Project  
 Paths: Project  
 Routes: Default Route  
 Configuration: Default Configuration

-----  
 Impact Analysis Report  
 Level Of Service  
 -----

Intersection		Base		Future		Change in
		Del/	V/	Del/	V/	
		LOS Veh	C	LOS Veh	C	
# 1 U.S. 101 SB Off-ramp/Yerba Bue	F	139.5	1.282	F 151.1	1.315	+11.642 D/V
# 2 U.S. 101 NB Off-ramp/Yerba Bue	C	25.5	0.891	C 26.8	0.911	+ 1.284 D/V
# 3 Silver Creek Road/Yerba Buena	B-	19.6	0.728	C+ 20.7	0.757	+ 1.151 D/V
# 4 Nieman Boulevard/Silver Creek	C	31.7	0.934	D+ 37.8	0.988	+ 6.126 D/V
# 5 Byington Drive/Yerba Buena Ave	B	13.1	0.774	B 15.8	0.810	+ 2.731 D/V
# 6 San Felipe Road/Yerba Buena Ro	E	63.0	1.075	E- 76.4	1.144	+13.341 D/V
# 7 Paseo de Arboles/San Felipe Ro	B	13.5	0.534	B 15.8	0.589	+ 2.300 D/V
# 8 Delta Road/San Felipe Road	B	15.9	0.507	B 15.5	0.528	-0.383 D/V
# 9 Fowler Road/San Felipe Road	B	12.6	0.474	B 12.4	0.495	-0.232 D/V
# 10 San Felipe Road/Yerba Buena Av	B	13.3	0.701	B 13.2	0.723	-0.055 D/V
# 11 Aborn Road/White Road/San Feli	E	63.7	0.957	E 66.4	0.987	+ 2.727 D/V
# 12 Aborn Road/Nieman Boulevard	D	46.6	0.948	D 49.7	0.969	+ 3.057 D/V
# 13 Capitol Expressway/Aborn Road	F	245.7	1.868	F 246.0	1.868	+ 0.250 D/V
# 14 Capitol Expressway/Silver Cree	D-	54.7	0.945	E+ 55.2	0.949	+ 0.463 D/V

Level Of Service Computation Report  
 2000 HCM Operations Method (Future Volume Alternative)

\*\*\*\*\*  
 Intersection #1 U.S. 101 SB Off-ramp/Yerba Buena Road  
 \*\*\*\*\*

Cycle (sec): 100 Critical Vol./Cap.(X): 1.315  
 Loss Time (sec): 0 Average Delay (sec/veh): 151.1  
 Optimal Cycle: 180 Level Of Service: F  
 \*\*\*\*\*

Street Name:	U.S. 101 SB Off-ramp						Yerba Buena Road					
Approach:	North Bound			South Bound			East Bound			West Bound		
Movement:	L	T	R	L	T	R	L	T	R	L	T	R
Control:	Protected			Protected			Protected			Protected		
Rights:	Include			Include			Include			Include		
Min. Green:	7	10	10	7	10	10	7	10	10	7	10	10
Y+R:	4.0	4.0	4.0	4.0	4.0	4.0	4.0	4.0	4.0	4.0	4.0	4.0
Lanes:	0	0	0	0	0	0	1	0	0	1	0	0

Volume Module:

Base Vol:	0	0	0	1220	40	120	0	680	85	710	450	0
Growth Adj:	1.00	1.00	1.00	1.00	1.00	1.00	1.00	1.00	1.00	1.00	1.00	1.00
Initial Bse:	0	0	0	1220	40	120	0	680	85	710	450	0
Added Vol:	0	0	0	43	0	0	0	5	0	13	3	0
PasserByVol:	0	0	0	0	0	0	0	0	0	0	0	0
Initial Fut:	0	0	0	1263	40	120	0	685	85	723	453	0
User Adj:	1.00	1.00	1.00	1.00	1.00	1.00	1.00	1.00	1.00	1.00	1.00	1.00
PHF Adj:	1.00	1.00	1.00	1.00	1.00	1.00	1.00	1.00	1.00	1.00	1.00	1.00
PHF Volume:	0	0	0	1263	40	120	0	685	85	723	453	0
Reduct Vol:	0	0	0	0	0	0	0	0	0	0	0	0
Reduced Vol:	0	0	0	1263	40	120	0	685	85	723	453	0
PCE Adj:	1.00	1.00	1.00	1.00	1.00	1.00	1.00	1.00	1.00	1.00	1.00	1.00
MLF Adj:	1.00	1.00	1.00	1.00	1.00	1.00	1.00	1.00	1.00	1.00	1.00	1.00
FinalVolume:	0	0	0	1263	40	120	0	685	85	723	453	0

Saturation Flow Module:

Sat/Lane:	1900	1900	1900	1900	1900	1900	1900	1900	1900	1900	1900	1900
Adjustment:	0.92	1.00	0.92	0.92	0.95	0.95	0.92	1.00	0.92	0.92	1.00	0.92
Lanes:	0.00	0.00	0.00	1.00	0.25	0.75	0.00	2.00	1.00	1.00	2.00	0.00
Final Sat.:	0	0	0	1750	450	1350	0	3800	1750	1750	3800	0

Capacity Analysis Module:

Vol/Sat:	0.00	0.00	0.00	0.72	0.09	0.09	0.00	0.18	0.05	0.41	0.12	0.00	
Crit Moves:				****				****					
Green Time:	0.0	0.0	0.0	54.9	38.2	38.2	0.0	13.7	13.7	31.4	28.4	0.0	
Volume/Cap:	0.00	0.00	0.00	1.32	0.23	0.23	0.00	1.32	0.35	1.32	0.42	0.00	
Uniform Del:	0.0	0.0	0.0	22.6	21.0	21.0	0.0	43.1	39.1	34.3	29.1	0.0	
IncrementDel:	0.0	0.0	0.0	149.2	0.2	0.2	0.0	155	0.9	154.4	0.3	0.0	
InitQueueDel:	0.0	0.0	0.0	0.0	0.0	0.0	0.0	0.0	0.0	0.0	0.0	0.0	
Delay Adj:	0.00	0.00	0.00	1.00	1.00	1.00	0.00	1.00	1.00	1.00	1.00	0.00	
Delay/Veh:	0.0	0.0	0.0	171.8	21.2	21.2	0.0	198	40.0	188.6	29.3	0.0	
User DelAdj:	1.00	1.00	1.00	1.00	1.00	1.00	1.00	1.00	1.00	1.00	1.00	1.00	
AdjDel/Veh:	0.0	0.0	0.0	171.8	21.2	21.2	0.0	198	40.0	188.6	29.3	0.0	
LOS by Move:	A	A	A	F	C+	C+	A	F	D	F	C	A	
HCM2kAvgQ:	0	0	0	83	3	3	0	23	3	47	5	0	

\*\*\*\*\*  
 Note: Queue reported is the number of cars per lane.  
 \*\*\*\*\*

Level Of Service Computation Report  
 2000 HCM Operations Method (Future Volume Alternative)

\*\*\*\*\*  
 Intersection #2 U.S. 101 NB Off-ramp/Yerba Buena Road  
 \*\*\*\*\*

Cycle (sec): 100 Critical Vol./Cap.(X): 0.911  
 Loss Time (sec): 0 Average Delay (sec/veh): 26.8  
 Optimal Cycle: 180 Level Of Service: C  
 \*\*\*\*\*

Street Name:	U.S. 101 NB Off-ram						Yerba Buena Road								
Approach:	North Bound			South Bound			East Bound			West Bound					
Movement:	L	T	R	L	T	R	L	T	R	L	T	R			
Control:	Protected			Protected			Protected			Protected					
Rights:	Include			Include			Include			Include					
Min. Green:	7	10	10	7	10	10	7	10	10	7	10	10			
Y+R:	4.0	4.0	4.0	4.0	4.0	4.0	4.0	4.0	4.0	4.0	4.0	4.0			
Lanes:	0	0	1	0	0	1	0	1	0	0	1	0	1	0	1

Volume Module:

Base Vol:	0	0	0	780	0	80	150	1770	0	0	1055	940
Growth Adj:	1.00	1.00	1.00	1.00	1.00	1.00	1.00	1.00	1.00	1.00	1.00	1.00
Initial Bse:	0	0	0	780	0	80	150	1770	0	0	1055	940
Added Vol:	0	0	0	25	0	0	0	48	0	0	16	22
PasserByVol:	0	0	0	0	0	0	0	0	0	0	0	0
Initial Fut:	0	0	0	805	0	80	150	1818	0	0	1071	962
User Adj:	1.00	1.00	1.00	1.00	1.00	1.00	1.00	1.00	1.00	1.00	1.00	1.00
PHF Adj:	1.00	1.00	1.00	1.00	1.00	1.00	1.00	1.00	1.00	1.00	1.00	1.00
PHF Volume:	0	0	0	805	0	80	150	1818	0	0	1071	962
Reduct Vol:	0	0	0	0	0	0	0	0	0	0	0	0
Reduced Vol:	0	0	0	805	0	80	150	1818	0	0	1071	962
PCE Adj:	1.00	1.00	1.00	1.00	1.00	1.00	1.00	1.00	1.00	1.00	1.00	1.00
MLF Adj:	1.00	1.00	1.00	1.00	1.00	1.00	1.00	1.00	1.00	1.00	1.00	1.00
FinalVolume:	0	0	0	805	0	80	150	1818	0	0	1071	962

Saturation Flow Module:

Sat/Lane:	1900	1900	1900	1900	1900	1900	1900	1900	1900	1900	1900	1900
Adjustment:	0.92	0.92	0.92	0.92	1.00	0.92	0.92	0.97	0.92	0.92	1.00	0.92
Lanes:	0.00	1.00	0.00	1.83	0.00	0.17	1.00	2.00	0.00	1.00	2.00	1.00
Final Sat.:	0	1750	0	3210	0	290	1750	3700	0	1750	3800	1750

Capacity Analysis Module:

Vol/Sat:	0.00	0.00	0.00	0.25	0.00	0.28	0.09	0.49	0.00	0.00	0.28	0.55
Crit Moves:				****		****	****			****		****
Green Time:	0.0	0.0	0.0	26.6	0.0	30.3	9.4	61.0	0.0	0.0	60.3	60.3
Volume/Cap:	0.00	0.00	0.00	0.94	0.00	0.91	0.91	0.80	0.00	0.00	0.47	0.91
Uniform Del:	0.0	0.0	0.0	35.9	0.0	33.6	44.9	14.9	0.0	0.0	11.0	17.5
IncrementDel:	0.0	0.0	0.0	17.0	0.0	12.4	45.2	2.2	0.0	0.0	0.2	11.6
InitQueueDel:	0.0	0.0	0.0	0.0	0.0	0.0	0.0	0.0	0.0	0.0	0.0	0.0
Delay Adj:	0.00	0.00	0.00	1.00	0.00	1.00	1.00	1.00	0.00	0.00	1.00	1.00
Delay/Veh:	0.0	0.0	0.0	52.9	0.0	46.0	90.0	17.1	0.0	0.0	11.1	29.1
User DelAdj:	1.00	1.00	1.00	1.00	1.00	1.00	1.00	1.00	1.00	1.00	1.00	1.00
AdjDel/Veh:	0.0	0.0	0.0	52.9	0.0	46.0	90.0	17.1	0.0	0.0	11.1	29.1
LOS by Move:	A	A	A	D-	A	D	F	B	A	A	B+	C
HCM2kAvgQ:	0	0	0	19	0	20	5	20	0	0	9	29

\*\*\*\*\*  
 Note: Queue reported is the number of cars per lane.  
 \*\*\*\*\*



Level Of Service Computation Report  
 2000 HCM Operations Method (Future Volume Alternative)

\*\*\*\*\*  
 Intersection #3 Silver Creek Road/Yerba Buena Road  
 \*\*\*\*\*

Cycle (sec): 100 Critical Vol./Cap.(X): 0.757  
 Loss Time (sec): 0 Average Delay (sec/veh): 20.7  
 Optimal Cycle: 94 Level Of Service: C+

Street Name:	Silver Creek Road						Yerba Buena Road					
Approach:	North Bound			South Bound			East Bound			West Bound		
Movement:	L	T	R	L	T	R	L	T	R	L	T	R
Control:	Protected			Protected			Protected			Protected		
Rights:	Include			Include			Include			Include		
Min. Green:	7	10	10	7	10	10	7	10	10	7	10	10
Y+R:	4.0	4.0	4.0	4.0	4.0	4.0	4.0	4.0	4.0	4.0	4.0	4.0
Lanes:	1	0	1	0	1	1	2	0	1	1	0	1

Volume Module:

Base Vol:	25	20	15	275	40	210	200	2225	55	25	1690	140
Growth Adj:	1.00	1.00	1.00	1.00	1.00	1.00	1.00	1.00	1.00	1.00	1.00	1.00
Initial Bse:	25	20	15	275	40	210	200	2225	55	25	1690	140
Added Vol:	0	0	0	26	0	0	0	73	0	0	38	14
PasserByVol:	0	0	0	0	0	0	0	0	0	0	0	0
Initial Fut:	25	20	15	301	40	210	200	2298	55	25	1728	154
User Adj:	1.00	1.00	1.00	1.00	1.00	1.00	1.00	1.00	1.00	1.00	1.00	1.00
PHF Adj:	1.00	1.00	1.00	1.00	1.00	1.00	1.00	1.00	1.00	1.00	1.00	1.00
PHF Volume:	25	20	15	301	40	210	200	2298	55	25	1728	154
Reduct Vol:	0	0	0	0	0	0	0	0	0	0	0	0
Reduced Vol:	25	20	15	301	40	210	200	2298	55	25	1728	154
PCE Adj:	1.00	1.00	1.00	1.00	1.00	1.00	1.00	1.00	1.00	1.00	1.00	1.00
MLF Adj:	1.00	1.00	1.00	1.00	1.00	1.00	1.00	1.00	1.00	1.00	1.00	1.00
FinalVolume:	25	20	15	301	40	210	200	2298	55	25	1728	154

Saturation Flow Module:

Sat/Lane:	1900	1900	1900	1900	1900	1900	1900	1900	1900	1900	1900	1900
Adjustment:	0.92	1.00	0.92	0.93	0.95	0.92	0.83	0.97	0.95	0.92	0.98	0.95
Lanes:	1.00	1.00	1.00	1.77	0.23	1.00	2.00	1.95	0.05	1.00	1.83	0.17
Final Sat.:	1750	1900	1750	3133	416	1750	3150	3613	86	1750	3397	303

Capacity Analysis Module:

Vol/Sat:	0.01	0.01	0.01	0.10	0.10	0.12	0.06	0.64	0.64	0.01	0.51	0.51
Crit Moves:	****			****			****			****		
Green Time:	7.7	10.0	10.0	10.9	13.2	13.2	9.6	72.1	72.1	7.0	69.5	69.5
Volume/Cap:	0.19	0.11	0.09	0.88	0.73	0.91	0.66	0.88	0.88	0.20	0.73	0.73
Uniform Del:	43.2	40.9	40.9	43.9	41.7	42.8	43.7	10.7	10.7	43.9	9.4	9.4
IncrementDel:	0.7	0.2	0.2	20.4	5.7	35.7	5.5	3.8	3.8	0.8	1.1	1.1
InitQueueDel:	0.0	0.0	0.0	0.0	0.0	0.0	0.0	0.0	0.0	0.0	0.0	0.0
Delay Adj:	1.00	1.00	1.00	1.00	1.00	1.00	1.00	1.00	1.00	1.00	1.00	1.00
Delay/Veh:	43.9	41.2	41.1	64.3	47.4	78.5	49.1	14.5	14.5	44.7	10.5	10.5
User DelAdj:	1.00	1.00	1.00	1.00	1.00	1.00	1.00	1.00	1.00	1.00	1.00	1.00
AdjDel/Veh:	43.9	41.2	41.1	64.3	47.4	78.5	49.1	14.5	14.5	44.7	10.5	10.5
LOS by Move:	D	D	D	E	D	E-	D	B	B	D	B+	B+
HCM2kAvgQ:	1	1	1	8	7	10	3	29	29	1	18	18

\*\*\*\*\*  
 Note: Queue reported is the number of cars per lane.  
 \*\*\*\*\*

Level Of Service Computation Report

2000 HCM Operations Method (Future Volume Alternative)

\*\*\*\*\*  
 Intersection #4 Nieman Boulevard/Silver Creek Valley Road/Yerba Buena Road  
 \*\*\*\*\*

Cycle (sec): 100 Critical Vol./Cap.(X): 0.988  
 Loss Time (sec): 0 Average Delay (sec/veh): 37.8  
 Optimal Cycle: 180 Level Of Service: D+  
 \*\*\*\*\*

Street Name:	Nieman Boulevard						Yerba Buena Road								
Approach:	North Bound			South Bound			East Bound			West Bound					
Movement:	L	T	R	L	T	R	L	T	R	L	T	R			
Control:	Protected			Protected			Protected			Protected					
Rights:	Include			Include			Include			Include					
Min. Green:	7	10	10	7	10	10	7	10	10	7	10	10			
Y+R:	4.0	4.0	4.0	4.0	4.0	4.0	4.0	4.0	4.0	4.0	4.0	4.0			
Lanes:	1	0	2	0	1	1	0	2	0	1	1	0	2	0	1

Volume Module:

Base Vol:	155	145	365	125	180	55	60	1930	215	255	1630	120
Growth Adj:	1.00	1.00	1.00	1.00	1.00	1.00	1.00	1.00	1.00	1.00	1.00	1.00
Initial Bse:	155	145	365	125	180	55	60	1930	215	255	1630	120
Added Vol:	0	0	25	11	0	0	0	99	0	13	52	6
PasserByVol:	0	0	0	0	0	0	0	0	0	0	0	0
Initial Fut:	155	145	390	136	180	55	60	2029	215	268	1682	126
User Adj:	1.00	1.00	1.00	1.00	1.00	1.00	1.00	1.00	1.00	1.00	1.00	1.00
PHF Adj:	1.00	1.00	1.00	1.00	1.00	1.00	1.00	1.00	1.00	1.00	1.00	1.00
PHF Volume:	155	145	390	136	180	55	60	2029	215	268	1682	126
Reduct Vol:	0	0	0	0	0	0	0	0	0	0	0	0
Reduced Vol:	155	145	390	136	180	55	60	2029	215	268	1682	126
PCE Adj:	1.00	1.00	1.00	1.00	1.00	1.00	1.00	1.00	1.00	1.00	1.00	1.00
MLF Adj:	1.00	1.00	1.00	1.00	1.00	1.00	1.00	1.00	1.00	1.00	1.00	1.00
FinalVolume:	155	145	390	136	180	55	60	2029	215	268	1682	126

Saturation Flow Module:

Sat/Lane:	1900	1900	1900	1900	1900	1900	1900	1900	1900	1900	1900	1900
Adjustment:	0.92	1.00	0.92	0.92	1.00	0.92	0.92	1.00	0.92	0.92	1.00	0.92
Lanes:	1.00	2.00	1.00	1.00	2.00	1.00	1.00	2.00	1.00	1.00	2.00	1.00
Final Sat.:	1750	3800	1750	1750	3800	1750	1750	3800	1750	1750	3800	1750

Capacity Analysis Module:

Vol/Sat:	0.09	0.04	0.22	0.08	0.05	0.03	0.03	0.53	0.12	0.15	0.44	0.07
Crit Moves:	****			****			****			****		
Green Time:	14.3	22.6	22.6	7.9	16.1	16.1	9.5	54.1	54.1	15.5	60.1	60.1
Volume/Cap:	0.62	0.17	0.99	0.99	0.29	0.19	0.36	0.99	0.23	0.99	0.74	0.12
Uniform Del:	40.3	31.2	38.6	46.0	36.9	36.3	42.4	22.6	12.0	42.2	14.3	8.6
IncrementDel:	4.7	0.1	41.9	72.7	0.3	0.3	1.3	17.0	0.1	51.1	1.3	0.1
InitQueueDel:	0.0	0.0	0.0	0.0	0.0	0.0	0.0	0.0	0.0	0.0	0.0	0.0
Delay Adj:	1.00	1.00	1.00	1.00	1.00	1.00	1.00	1.00	1.00	1.00	1.00	1.00
Delay/Veh:	45.0	31.3	80.5	118.8	37.2	36.6	43.7	39.6	12.2	93.2	15.6	8.6
User DelAdj:	1.00	1.00	1.00	1.00	1.00	1.00	1.00	1.00	1.00	1.00	1.00	1.00
AdjDel/Veh:	45.0	31.3	80.5	118.8	37.2	36.6	43.7	39.6	12.2	93.2	15.6	8.6
LOS by Move:	D	C	F	F	D+	D+	D	D	B	F	B	A
HCM2kAvgQ:	6	2	19	8	3	2	2	33	3	10	18	2

\*\*\*\*\*  
 Note: Queue reported is the number of cars per lane.  
 \*\*\*\*\*

Level Of Service Computation Report  
 2000 HCM Operations Method (Future Volume Alternative)

\*\*\*\*\*  
 Intersection #5 Byington Drive/Yerba Buena Avenue/Yerba Buena Road  
 \*\*\*\*\*

Cycle (sec): 100 Critical Vol./Cap.(X): 0.810  
 Loss Time (sec): 0 Average Delay (sec/veh): 15.8  
 Optimal Cycle: 120 Level Of Service: B  
 \*\*\*\*\*

Street Name:	Byington Drive						Yerba Buena Avenue									
	North Bound			South Bound			East Bound			West Bound						
Approach:	L - T - R		L - T - R		L - T - R		L - T - R		L - T - R		L - T - R					
Movement:	L	T	R	L	T	R	L	T	R	L	T	R				
Control:	Protected			Protected			Protected			Protected						
Rights:	Include			Include			Include			Include						
Min. Green:	7	10	10	7	10	10	7	10	10	7	10	10				
Y+R:	4.0	4.0	4.0	4.0	4.0	4.0	4.0	4.0	4.0	4.0	4.0	4.0				
Lanes:	0	0	1	0	0	0	0	0	1	0	0	1	0	1	1	0

Volume Module:

Base Vol:	10	0	25	25	0	50	55	2520	15	45	1995	75
Growth Adj:	1.00	1.00	1.00	1.00	1.00	1.00	1.00	1.00	1.00	1.00	1.00	1.00
Initial Bse:	10	0	25	25	0	50	55	2520	15	45	1995	75
Added Vol:	0	0	0	0	0	0	0	135	0	0	71	0
PasserByVol:	0	0	0	0	0	0	0	0	0	0	0	0
Initial Fut:	10	0	25	25	0	50	55	2655	15	45	2066	75
User Adj:	1.00	1.00	1.00	1.00	1.00	1.00	1.00	1.00	1.00	1.00	1.00	1.00
PHF Adj:	1.00	1.00	1.00	1.00	1.00	1.00	1.00	1.00	1.00	1.00	1.00	1.00
PHF Volume:	10	0	25	25	0	50	55	2655	15	45	2066	75
Reduct Vol:	0	0	0	0	0	0	0	0	0	0	0	0
Reduced Vol:	10	0	25	25	0	50	55	2655	15	45	2066	75
PCE Adj:	1.00	1.00	1.00	1.00	1.00	1.00	1.00	1.00	1.00	1.00	1.00	1.00
MLF Adj:	1.00	1.00	1.00	1.00	1.00	1.00	1.00	1.00	1.00	1.00	1.00	1.00
FinalVolume:	10	0	25	25	0	50	55	2655	15	45	2066	75

Saturation Flow Module:

Sat/Lane:	1900	1900	1900	1900	1900	1900	1900	1900	1900	1900	1900	1900
Adjustment:	0.92	0.92	0.92	0.92	0.92	0.92	0.92	0.97	0.95	0.92	0.97	0.95
Lanes:	0.29	0.00	0.71	0.33	0.00	0.67	1.00	1.99	0.01	1.00	1.93	0.07
Final Sat.:	500	0	1250	583	0	1167	1750	3679	21	1750	3570	130

Capacity Analysis Module:

Vol/Sat:	0.02	0.00	0.02	0.04	0.00	0.04	0.03	0.72	0.72	0.03	0.58	0.58
Crit Moves:	****			****		****	****		****	****		****
Green Time:	7.0	0.0	10.0	7.0	0.0	10.0	9.0	76.0	76.0	7.0	74.0	74.0
Volume/Cap:	0.29	0.00	0.20	0.61	0.00	0.43	0.35	0.95	0.95	0.37	0.78	0.78
Uniform Del:	44.1	0.0	41.3	45.2	0.0	42.3	42.8	10.3	10.3	44.4	8.0	8.0
IncrementDel:	1.3	0.0	0.6	8.8	0.0	1.7	1.4	8.1	8.1	1.9	1.5	1.5
InitQueueDel:	0.0	0.0	0.0	0.0	0.0	0.0	0.0	0.0	0.0	0.0	0.0	0.0
Delay Adj:	1.00	0.00	1.00	1.00	0.00	1.00	1.00	1.00	1.00	1.00	1.00	1.00
Delay/Veh:	45.4	0.0	41.9	54.0	0.0	44.0	44.1	18.5	18.5	46.3	9.5	9.5
User DelAdj:	1.00	1.00	1.00	1.00	1.00	1.00	1.00	1.00	1.00	1.00	1.00	1.00
AdjDel/Veh:	45.4	0.0	41.9	54.0	0.0	44.0	44.1	18.5	18.5	46.3	9.5	9.5
LOS by Move:	D	A	D	D-	A	D	D	B-	B-	D	A	A
HCM2kAvgQ:	1	0	1	4	0	3	2	35	35	1	19	19

\*\*\*\*\*  
 Note: Queue reported is the number of cars per lane.  
 \*\*\*\*\*

Level Of Service Computation Report  
 2000 HCM Operations Method (Future Volume Alternative)

\*\*\*\*\*  
 Intersection #6 San Felipe Road/Yerba Buena Road  
 \*\*\*\*\*

Cycle (sec): 120 Critical Vol./Cap.(X): 1.144  
 Loss Time (sec): 0 Average Delay (sec/veh): 76.4  
 Optimal Cycle: 180 Level Of Service: E-  
 \*\*\*\*\*

Street Name:	San Felipe Road						Yerba Buena Road					
Approach:	North Bound			South Bound			East Bound			West Bound		
Movement:	L	T	R	L	T	R	L	T	R	L	T	R
Control:	Protected			Protected			Protected			Protected		
Rights:	Include			Include			Include			Include		
Min. Green:	7	10	10	7	10	10	7	10	10	7	10	10
Y+R:	4.0	4.0	4.0	4.0	4.0	4.0	4.0	4.0	4.0	4.0	4.0	4.0
Lanes:	2	0	2	0	1	1	1	0	2	0	1	1

Volume Module:

Base Vol:	215	425	155	300	455	520	595	1545	350	210	1405	315
Growth Adj:	1.00	1.00	1.00	1.00	1.00	1.00	1.00	1.00	1.00	1.00	1.00	1.00
Initial Bse:	215	425	155	300	455	520	595	1545	350	210	1405	315
Added Vol:	0	13	13	43	7	36	68	68	0	7	36	26
PasserByVol:	0	0	0	0	0	0	0	0	0	0	0	0
Initial Fut:	215	438	168	343	462	556	663	1613	350	217	1441	341
User Adj:	1.00	1.00	1.00	1.00	1.00	1.00	1.00	1.00	1.00	1.00	1.00	1.00
PHF Adj:	1.00	1.00	1.00	1.00	1.00	1.00	1.00	1.00	1.00	1.00	1.00	1.00
PHF Volume:	215	438	168	343	462	556	663	1613	350	217	1441	341
Reduct Vol:	0	0	0	0	0	0	0	0	0	0	0	0
Reduced Vol:	215	438	168	343	462	556	663	1613	350	217	1441	341
PCE Adj:	1.00	1.00	1.00	1.00	1.00	1.00	1.00	1.00	1.00	1.00	1.00	1.00
MLF Adj:	1.00	1.00	1.00	1.00	1.00	1.00	1.00	1.00	1.00	1.00	1.00	1.00
FinalVolume:	215	438	168	343	462	556	663	1613	350	217	1441	341

Saturation Flow Module:

Sat/Lane:	1900	1900	1900	1900	1900	1900	1900	1900	1900	1900	1900	1900
Adjustment:	0.83	1.00	0.92	0.92	1.00	0.92	0.92	1.00	0.92	0.92	1.00	0.92
Lanes:	2.00	2.00	1.00	1.00	2.00	1.00	1.00	2.00	1.00	1.00	2.00	1.00
Final Sat.:	3150	3800	1750	1750	3800	1750	1750	3800	1750	1750	3800	1750

Capacity Analysis Module:

Vol/Sat:	0.07	0.12	0.10	0.20	0.12	0.32	0.38	0.42	0.20	0.12	0.38	0.19
Crit Moves:	****					****	****			****		
Green Time:	7.2	15.0	15.0	25.5	33.3	33.3	39.7	61.5	61.5	18.0	39.8	39.8
Volume/Cap:	1.14	0.92	0.77	0.92	0.44	1.14	1.14	0.83	0.39	0.83	1.14	0.59
Uniform Del:	56.4	51.9	50.8	46.3	35.6	43.3	40.1	24.7	17.8	49.5	40.1	33.3
IncrementDel:	109.7	23.6	15.2	28.0	0.3	86.8	83.9	3.1	0.3	19.2	74.7	1.6
InitQueueDel:	0.0	0.0	0.0	0.0	0.0	0.0	0.0	0.0	0.0	0.0	0.0	0.0
Delay Adj:	1.00	1.00	1.00	1.00	1.00	1.00	1.00	1.00	1.00	1.00	1.00	1.00
Delay/Veh:	166.2	75.5	66.0	74.3	35.9	130.1	124.0	27.8	18.1	68.7	115	34.9
User DelAdj:	1.00	1.00	1.00	1.00	1.00	1.00	1.00	1.00	1.00	1.00	1.00	1.00
AdjDel/Veh:	166.2	75.5	66.0	74.3	35.9	130.1	124.0	27.8	18.1	68.7	115	34.9
LOS by Move:	F	E-	E	E	D+	F	F	C	B-	E	F	C-
HCM2kAvgQ:	9	11	8	17	7	35	36	24	8	11	41	12

\*\*\*\*\*  
 Note: Queue reported is the number of cars per lane.  
 \*\*\*\*\*

Level of Service Computation Report  
 2000 HCM Operations Method (Future Volume Alternative)

\*\*\*\*\*  
 Intersection #7 Paseo de Arboles/San Felipe Road  
 \*\*\*\*\*

Cycle (sec): 100 Critical Vol./Cap.(X): 0.589  
 Loss Time (sec): 0 Average Delay (sec/veh): 15.8  
 Optimal Cycle: 55 Level of Service: B  
 \*\*\*\*\*

Street Name:	San Felipe Road				Paseo de Arboles										
Approach:	North Bound		South Bound		East Bound		West Bound								
Movement:	L	T	R	L	T	R	L	T	R	L	T	R			
Control:	Protected		Protected		Protected		Protected								
Rights:	Include		Include		Include		Include								
Min. Green:	7	10	10	7	10	10	7	10	10	7	10	10			
Y+R:	4.0	4.0	4.0	4.0	4.0	4.0	4.0	4.0	4.0	4.0	4.0	4.0			
Lanes:	1	0	2	0	1	1	0	2	0	0	0	0	0	0	1

Volume Module:

Base Vol:	50	1195	175	260	1335	0	0	0	0	125	0	80
Growth Adj:	1.00	1.00	1.00	1.00	1.00	1.00	1.00	1.00	1.00	1.00	1.00	1.00
Initial Bse:	50	1195	175	260	1335	0	0	0	0	125	0	80
Added Vol:	0	21	85	40	40	0	0	0	0	45	0	21
PasserByVol:	0	0	0	0	0	0	0	0	0	0	0	0
Initial Fut:	50	1216	260	300	1375	0	0	0	0	170	0	101
User Adj:	1.00	1.00	1.00	1.00	1.00	1.00	1.00	1.00	1.00	1.00	1.00	1.00
PHF Adj:	1.00	1.00	1.00	1.00	1.00	1.00	1.00	1.00	1.00	1.00	1.00	1.00
PHF Volume:	50	1216	260	300	1375	0	0	0	0	170	0	101
Reduct Vol:	0	0	0	0	0	0	0	0	0	0	0	0
Reduced Vol:	50	1216	260	300	1375	0	0	0	0	170	0	101
PCE Adj:	1.00	1.00	1.00	1.00	1.00	1.00	1.00	1.00	1.00	1.00	1.00	1.00
MLF Adj:	1.00	1.00	1.00	1.00	1.00	1.00	1.00	1.00	1.00	1.00	1.00	1.00
FinalVolume:	50	1216	260	300	1375	0	0	0	0	170	0	101

Saturation Flow Module:

Sat/Lane:	1900	1900	1900	1900	1900	1900	1900	1900	1900	1900	1900	1900
Adjustment:	0.92	1.00	0.92	0.92	1.00	0.92	0.92	1.00	0.92	0.92	1.00	0.92
Lanes:	1.00	2.00	1.00	1.00	2.00	0.00	0.00	0.00	0.00	1.00	0.00	1.00
Final Sat.:	1750	3800	1750	1750	3800	0	0	0	0	1750	0	1750

Capacity Analysis Module:

Vol/Sat:	0.03	0.32	0.15	0.17	0.36	0.00	0.00	0.00	0.00	0.10	0.00	0.06
Crit Moves:	****			****			****			****		
Green Time:	13.5	54.4	54.4	29.1	70.0	0.0	0.0	0.0	0.0	16.5	0.0	15.6
Volume/Cap:	0.21	0.59	0.27	0.59	0.52	0.00	0.00	0.00	0.00	0.59	0.00	0.37
Uniform Del:	38.5	15.3	12.2	30.3	7.1	0.0	0.0	0.0	0.0	38.6	0.0	37.8
IncrementDel:	0.4	0.4	0.2	1.8	0.2	0.0	0.0	0.0	0.0	3.2	0.0	0.9
InitQueueDel:	0.0	0.0	0.0	0.0	0.0	0.0	0.0	0.0	0.0	0.0	0.0	0.0
Delay Adj:	1.00	1.00	1.00	1.00	1.00	0.00	0.00	0.00	0.00	1.00	0.00	1.00
Delay/Veh:	38.9	15.8	12.4	32.1	7.2	0.0	0.0	0.0	0.0	41.8	0.0	38.7
User DelAdj:	1.00	1.00	1.00	1.00	1.00	1.00	1.00	1.00	1.00	1.00	1.00	1.00
AdjDel/Veh:	38.9	15.8	12.4	32.1	7.2	0.0	0.0	0.0	0.0	41.8	0.0	38.7
LOS by Move:	D+	B	B	C-	A	A	A	A	A	D	A	D+
HCM2kAvgQ:	2	13	5	8	10	0	0	0	0	6	0	3

\*\*\*\*\*  
 Note: Queue reported is the number of cars per lane.  
 \*\*\*\*\*

Level Of Service Computation Report  
 2000 HCM Operations Method (Future Volume Alternative)

\*\*\*\*\*  
 Intersection #8 Delta Road/San Felipe Road  
 \*\*\*\*\*

Cycle (sec): 100 Critical Vol./Cap.(X): 0.528  
 Loss Time (sec): 0 Average Delay (sec/veh): 15.5  
 Optimal Cycle: 48 Level Of Service: B  
 \*\*\*\*\*

Street Name:	San Felipe Road						Delta Road													
Approach:	North Bound			South Bound			East Bound			West Bound										
Movement:	L	T	R	L	T	R	L	T	R	L	T	R								
Control:	Protected			Protected			Protected			Protected										
Rights:	Include			Include			Include			Include										
Min. Green:	7	10	10	7	10	10	7	10	10	7	10	10								
Y+R:	4.0	4.0	4.0	4.0	4.0	4.0	4.0	4.0	4.0	4.0	4.0	4.0								
Lanes:	1	0	2	0	1	1	0	2	0	0	0	0	0	0	0	1	0	0	0	1

Volume Module:

Base Vol:	5	1070	290	213	1395	0	0	0	0	240	0	110
Growth Adj:	1.00	1.00	1.00	1.00	1.00	1.00	1.00	1.00	1.00	1.00	1.00	1.00
Initial Bse:	5	1070	290	213	1395	0	0	0	0	240	0	110
Added Vol:	0	42	0	0	80	0	0	0	0	0	0	0
PasserByVol:	0	0	0	0	0	0	0	0	0	0	0	0
Initial Fut:	5	1112	290	213	1475	0	0	0	0	240	0	110
User Adj:	1.00	1.00	1.00	1.00	1.00	1.00	1.00	1.00	1.00	1.00	1.00	1.00
PHF Adj:	1.00	1.00	1.00	1.00	1.00	1.00	1.00	1.00	1.00	1.00	1.00	1.00
PHF Volume:	5	1112	290	213	1475	0	0	0	0	240	0	110
Reduct Vol:	0	0	0	0	0	0	0	0	0	0	0	0
Reduced Vol:	5	1112	290	213	1475	0	0	0	0	240	0	110
PCE Adj:	1.00	1.00	1.00	1.00	1.00	1.00	1.00	1.00	1.00	1.00	1.00	1.00
MLF Adj:	1.00	1.00	1.00	1.00	1.00	1.00	1.00	1.00	1.00	1.00	1.00	1.00
FinalVolume:	5	1112	290	213	1475	0	0	0	0	240	0	110

Saturation Flow Module:

Sat/Lane:	1900	1900	1900	1900	1900	1900	1900	1900	1900	1900	1900	1900
Adjustment:	0.92	1.00	0.92	0.92	1.00	0.92	0.92	1.00	0.92	0.92	1.00	0.92
Lanes:	1.00	2.00	1.00	1.00	2.00	0.00	0.00	0.00	0.00	1.00	0.00	1.00
Final Sat.:	1750	3800	1750	1750	3800	0	0	0	0	1750	0	1750

Capacity Analysis Module:

Vol/Sat:	0.00	0.29	0.17	0.12	0.39	0.00	0.00	0.00	0.00	0.14	0.00	0.06
Crit Moves:	****			****			****			****		
Green Time:	7.0	53.5	53.5	22.2	68.7	0.0	0.0	0.0	0.0	24.3	0.0	20.2
Volume/Cap:	0.04	0.55	0.31	0.55	0.56	0.00	0.00	0.00	0.00	0.56	0.00	0.31
Uniform Del:	43.4	15.3	13.0	34.4	8.0	0.0	0.0	0.0	0.0	33.2	0.0	34.0
IncrementDel:	0.1	0.3	0.2	1.6	0.3	0.0	0.0	0.0	0.0	1.8	0.0	0.5
InitQueueDel:	0.0	0.0	0.0	0.0	0.0	0.0	0.0	0.0	0.0	0.0	0.0	0.0
Delay Adj:	1.00	1.00	1.00	1.00	1.00	0.00	0.00	0.00	0.00	1.00	0.00	1.00
Delay/Veh:	43.5	15.6	13.2	36.1	8.3	0.0	0.0	0.0	0.0	35.0	0.0	34.5
User DelAdj:	1.00	1.00	1.00	1.00	1.00	1.00	1.00	1.00	1.00	1.00	1.00	1.00
AdjDel/Veh:	43.5	15.6	13.2	36.1	8.3	0.0	0.0	0.0	0.0	35.0	0.0	34.5
LOS by Move:	D	B	B	D+	A	A	A	A	A	C-	A	C-
HCM2kAvgQ:	0	11	5	6	11	0	0	0	0	8	0	3

\*\*\*\*\*  
 Note: Queue reported is the number of cars per lane.  
 \*\*\*\*\*

Level Of Service Computation Report  
 2000 HCM Operations Method (Future Volume Alternative)

\*\*\*\*\*  
 Intersection #9 Fowler Road/San Felipe Road  
 \*\*\*\*\*

Cycle (sec): 100 Critical Vol./Cap.(X): 0.495  
 Loss Time (sec): 0 Average Delay (sec/veh): 12.4  
 Optimal Cycle: 45 Level Of Service: B  
 \*\*\*\*\*

Street Name:	San Felipe Road						Fowler Road					
Approach:	North Bound			South Bound			East Bound			West Bound		
Movement:	L	T	R	L	T	R	L	T	R	L	T	R
Control:	Protected			Protected			Protected			Protected		
Rights:	Include			Include			Include			Include		
Min. Green:	7	10	10	7	10	10	7	10	10	7	10	10
Y+R:	4.0	4.0	4.0	4.0	4.0	4.0	4.0	4.0	4.0	4.0	4.0	4.0
Lanes:	1	0	2	0	1	1	1	0	2	0	0	1

Volume Module:

Base Vol:	15	1075	115	205	1475	0	0	0	0	120	0	135
Growth Adj:	1.00	1.00	1.00	1.00	1.00	1.00	1.00	1.00	1.00	1.00	1.00	1.00
Initial Bse:	15	1075	115	205	1475	0	0	0	0	120	0	135
Added Vol:	0	42	0	0	80	0	0	0	0	0	0	0
PasserByVol:	0	0	0	0	0	0	0	0	0	0	0	0
Initial Fut:	15	1117	115	205	1555	0	0	0	0	120	0	135
User Adj:	1.00	1.00	1.00	1.00	1.00	1.00	1.00	1.00	1.00	1.00	1.00	1.00
PHF Adj:	1.00	1.00	1.00	1.00	1.00	1.00	1.00	1.00	1.00	1.00	1.00	1.00
PHF Volume:	15	1117	115	205	1555	0	0	0	0	120	0	135
Reduct Vol:	0	0	0	0	0	0	0	0	0	0	0	0
Reduced Vol:	15	1117	115	205	1555	0	0	0	0	120	0	135
PCE Adj:	1.00	1.00	1.00	1.00	1.00	1.00	1.00	1.00	1.00	1.00	1.00	1.00
MLF Adj:	1.00	1.00	1.00	1.00	1.00	1.00	1.00	1.00	1.00	1.00	1.00	1.00
FinalVolume:	15	1117	115	205	1555	0	0	0	0	120	0	135

Saturation Flow Module:

Sat/Lane:	1900	1900	1900	1900	1900	1900	1900	1900	1900	1900	1900	1900
Adjustment:	0.92	1.00	0.92	0.92	1.00	0.92	0.92	1.00	0.92	0.92	1.00	0.92
Lanes:	1.00	2.00	1.00	1.00	2.00	0.00	0.00	0.00	0.00	1.00	0.00	1.00
Final Sat.:	1750	3800	1750	1750	3800	0	0	0	0	1750	0	1750

Capacity Analysis Module:

Vol/Sat:	0.01	0.29	0.07	0.12	0.41	0.00	0.00	0.00	0.00	0.07	0.00	0.08
Crit Moves:	****			****						****		
Green Time:	7.0	61.0	61.0	24.3	78.2	0.0	0.0	0.0	0.0	9.0	0.0	14.8
Volume/Cap:	0.12	0.48	0.11	0.48	0.52	0.00	0.00	0.00	0.00	0.77	0.00	0.52
Uniform Del:	43.6	10.8	8.2	32.5	4.0	0.0	0.0	0.0	0.0	44.5	0.0	39.4
IncrementDel:	0.5	0.2	0.0	0.9	0.2	0.0	0.0	0.0	0.0	19.9	0.0	1.9
InitQueueDel:	0.0	0.0	0.0	0.0	0.0	0.0	0.0	0.0	0.0	0.0	0.0	0.0
Delay Adj:	1.00	1.00	1.00	1.00	1.00	0.00	0.00	0.00	0.00	1.00	0.00	1.00
Delay/Veh:	44.1	11.0	8.2	33.3	4.2	0.0	0.0	0.0	0.0	64.4	0.0	41.3
User DelAdj:	1.00	1.00	1.00	1.00	1.00	1.00	1.00	1.00	1.00	1.00	1.00	1.00
AdjDel/Veh:	44.1	11.0	8.2	33.3	4.2	0.0	0.0	0.0	0.0	64.4	0.0	41.3
LOS by Move:	D	B+	A	C-	A	A	A	A	A	E	A	D
HCM2kAvgQ:	0	9	2	6	9	0	0	0	0	6	0	5

\*\*\*\*\*  
 Note: Queue reported is the number of cars per lane.  
 \*\*\*\*\*

Level of Service Computation Report

2000 HCM Operations Method (Future Volume Alternative)

\*\*\*\*\*  
 Intersection #10 San Felipe Road/Yerba Buena Avenue  
 \*\*\*\*\*

Cycle (sec): 100 Critical Vol./Cap.(X): 0.723  
 Loss Time (sec): 0 Average Delay (sec/veh): 13.2  
 Optimal Cycle: 82 Level Of Service: B  
 \*\*\*\*\*

Street Name:	San Felipe Road						Yerba Buena Avenue														
Approach:	North Bound			South Bound			East Bound			West Bound											
Movement:	L	T	R	L	T	R	L	T	R	L	T	R									
Control:	Protected			Protected			Protected			Protected											
Rights:	Include			Include			Include			Include											
Min. Green:	7	10	10	7	10	10	7	10	10	7	10	10									
Y+R:	4.0	4.0	4.0	4.0	4.0	4.0	4.0	4.0	4.0	4.0	4.0	4.0									
Lanes:	1	0	2	0	0	0	0	0	1	1	0	0	0	1	0	0	0	0	0	0	0

Volume Module:

Base Vol:	75	1120	0	0	1600	255	180	0	95	0	0	0
Growth Adj:	1.00	1.00	1.00	1.00	1.00	1.00	1.00	1.00	1.00	1.00	1.00	1.00
Initial Bse:	75	1120	0	0	1600	255	180	0	95	0	0	0
Added Vol:	0	42	0	0	80	0	0	0	0	0	0	0
PasserByVol:	0	0	0	0	0	0	0	0	0	0	0	0
Initial Fut:	75	1162	0	0	1680	255	180	0	95	0	0	0
User Adj:	1.00	1.00	1.00	1.00	1.00	1.00	1.00	1.00	1.00	1.00	1.00	1.00
PHF Adj:	1.00	1.00	1.00	1.00	1.00	1.00	1.00	1.00	1.00	1.00	1.00	1.00
PHF Volume:	75	1162	0	0	1680	255	180	0	95	0	0	0
Reduct Vol:	0	0	0	0	0	0	0	0	0	0	0	0
Reduced Vol:	75	1162	0	0	1680	255	180	0	95	0	0	0
PCE Adj:	1.00	1.00	1.00	1.00	1.00	1.00	1.00	1.00	1.00	1.00	1.00	1.00
MLF Adj:	1.00	1.00	1.00	1.00	1.00	1.00	1.00	1.00	1.00	1.00	1.00	1.00
FinalVolume:	75	1162	0	0	1680	255	180	0	95	0	0	0

Saturation Flow Module:

Sat/Lane:	1900	1900	1900	1900	1900	1900	1900	1900	1900	1900	1900	1900
Adjustment:	0.92	1.00	0.92	0.92	0.98	0.95	0.92	0.92	0.92	0.92	1.00	0.92
Lanes:	1.00	2.00	0.00	0.00	1.73	0.27	0.65	0.00	0.35	0.00	0.00	0.00
Final Sat.:	1750	3800	0	0	3212	488	1145	0	605	0	0	0

Capacity Analysis Module:

Vol/Sat:	0.04	0.31	0.00	0.00	0.52	0.52	0.16	0.00	0.16	0.00	0.00	0.00
Crit Moves:	****			****			****					
Green Time:	7.0	63.9	0.0	0.0	71.5	71.5	21.5	0.0	21.8	0.0	0.0	0.0
Volume/Cap:	0.61	0.48	0.00	0.00	0.73	0.73	0.73	0.00	0.72	0.00	0.00	0.00
Uniform Del:	45.2	9.4	0.0	0.0	8.5	8.5	36.6	0.0	36.3	0.0	0.0	0.0
IncrementDel:	8.8	0.1	0.0	0.0	1.1	1.1	7.2	0.0	6.6	0.0	0.0	0.0
InitQueueDel:	0.0	0.0	0.0	0.0	0.0	0.0	0.0	0.0	0.0	0.0	0.0	0.0
Delay Adj:	1.00	1.00	0.00	0.00	1.00	1.00	1.00	0.00	1.00	0.00	0.00	0.00
Delay/Veh:	54.0	9.5	0.0	0.0	9.6	9.6	43.8	0.0	42.9	0.0	0.0	0.0
User DelAdj:	1.00	1.00	1.00	1.00	1.00	1.00	1.00	1.00	1.00	1.00	1.00	1.00
AdjDel/Veh:	54.0	9.5	0.0	0.0	9.6	9.6	43.8	0.0	42.9	0.0	0.0	0.0
LOS by Move:	D-	A	A	A	A	A	D	A	D	A	A	A
HCM2kAvgQ:	2	9	0	0	17	17	10	0	10	0	0	0

\*\*\*\*\*  
 Note: Queue reported is the number of cars per lane.  
 \*\*\*\*\*



Level Of Service Computation Report  
2000 HCM Operations Method (Future Volume Alternative)

\*\*\*\*\*  
Intersection #11 Aborn Road/White Road/San Felipe Road  
\*\*\*\*\*

Cycle (sec): 155 Critical Vol./Cap.(X): 0.987  
Loss Time (sec): 0 Average Delay (sec/veh): 66.4  
Optimal Cycle: 180 Level Of Service: E  
\*\*\*\*\*

Street Name:	San Felipe Road						Aborn Road					
Approach:	North Bound			South Bound			East Bound			West Bound		
Movement:	L	T	R	L	T	R	L	T	R	L	T	R
Control:	Protected			Protected			Protected			Protected		
Rights:	Include			Include			Include			Include		
Min. Green:	7	10	10	7	10	10	7	10	10	7	10	10
Y+R:	4.0	4.0	4.0	4.0	4.0	4.0	4.0	4.0	4.0	4.0	4.0	4.0
Lanes:	2	0	2	0	1	1	2	0	2	0	1	1

Volume Module:

Base Vol:	530	835	135	255	1040	400	535	1795	565	310	1970	280
Growth Adj:	1.00	1.00	1.00	1.00	1.00	1.00	1.00	1.00	1.00	1.00	1.00	1.00
Initial Bse:	530	835	135	255	1040	400	535	1795	565	310	1970	280
Added Vol:	21	13	8	0	25	0	0	0	40	15	0	0
PasserByVol:	0	0	0	0	0	0	0	0	0	0	0	0
Initial Fut:	551	848	143	255	1065	400	535	1795	605	325	1970	280
User Adj:	1.00	1.00	1.00	1.00	1.00	1.00	1.00	1.00	1.00	1.00	1.00	1.00
PHF Adj:	1.00	1.00	1.00	1.00	1.00	1.00	1.00	1.00	1.00	1.00	1.00	1.00
PHF Volume:	551	848	143	255	1065	400	535	1795	605	325	1970	280
Reduct Vol:	0	0	0	0	0	0	0	0	0	0	0	0
Reduced Vol:	551	848	143	255	1065	400	535	1795	605	325	1970	280
PCE Adj:	1.00	1.00	1.00	1.00	1.00	1.00	1.00	1.00	1.00	1.00	1.00	1.00
MLF Adj:	1.00	1.00	1.00	1.00	1.00	1.00	1.00	1.00	1.00	1.00	1.00	1.00
FinalVolume:	551	848	143	255	1065	400	535	1795	605	325	1970	280

Saturation Flow Module:

Sat/Lane:	1900	1900	1900	1900	1900	1900	1900	1900	1900	1900	1900	1900
Adjustment:	0.83	1.00	0.92	0.83	1.00	0.92	0.83	1.00	0.92	0.92	1.00	0.92
Lanes:	2.00	2.00	1.00	2.00	2.00	1.00	2.00	3.00	1.00	1.00	3.00	1.00
Final Sat.:	3150	3800	1750	3150	3800	1750	3150	5700	1750	1750	5700	1750

Capacity Analysis Module:

Vol/Sat:	0.17	0.22	0.08	0.08	0.28	0.23	0.17	0.31	0.35	0.19	0.35	0.16
Crit Moves:	****			****			****		****			
Green Time:	27.5	52.5	52.5	19.0	44.0	44.0	27.5	54.3	54.3	29.2	56.0	56.0
Volume/Cap:	0.99	0.66	0.24	0.66	0.99	0.80	0.96	0.90	0.99	0.99	0.96	0.44
Uniform Del:	63.6	43.6	36.9	64.9	55.2	51.5	63.2	47.7	50.0	62.7	48.3	37.7
IncrementDel:	34.5	1.3	0.2	4.2	24.1	9.3	27.5	5.9	32.8	45.8	11.4	0.5
InitQueueDel:	0.0	0.0	0.0	0.0	0.0	0.0	0.0	0.0	0.0	0.0	0.0	0.0
Delay Adj:	1.00	1.00	1.00	1.00	1.00	1.00	1.00	1.00	1.00	1.00	1.00	1.00
Delay/Veh:	98.1	44.9	37.1	69.0	79.3	60.8	90.7	53.7	82.8	108.5	59.7	38.2
User DelAdj:	1.00	1.00	1.00	1.00	1.00	1.00	1.00	1.00	1.00	1.00	1.00	1.00
AdjDel/Veh:	98.1	44.9	37.1	69.0	79.3	60.8	90.7	53.7	82.8	108.5	59.7	38.2
LOS by Move:	F	D	D+	E	E-	E	F	D-	F	F	E+	D+
HCM2kAvgQ:	18	17	5	8	31	21	15	25	31	21	35	11

\*\*\*\*\*  
Note: Queue reported is the number of cars per lane.  
\*\*\*\*\*

Level Of Service Computation Report  
 2000 HCM Operations Method (Future Volume Alternative)

\*\*\*\*\*  
 Intersection #12 Aborn Road/Nieman Boulevard  
 \*\*\*\*\*

Cycle (sec): 170 Critical Vol./Cap.(X): 0.969  
 Loss Time (sec): 0 Average Delay (sec/veh): 49.7  
 Optimal Cycle: 180 Level Of Service: D  
 \*\*\*\*\*

Street Name:	Nieman Boulevard						Aborn Road									
Approach:	North Bound			South Bound			East Bound			West Bound						
Movement:	L	T	R	L	T	R	L	T	R	L	T	R				
Control:	Protected			Protected			Protected			Protected						
Rights:	Include			Include			Include			Include						
Min. Green:	7	10	10	7	10	10	7	10	10	7	10	10				
Y+R:	4.0	4.0	4.0	4.0	4.0	4.0	4.0	4.0	4.0	4.0	4.0	4.0				
Lanes:	1	0	2	0	1	1	0	2	0	1	1	0	2	1	0	1

Volume Module:

Base Vol:	65	140	140	490	245	70	25	2680	85	165	2585	410
Growth Adj:	1.00	1.00	1.00	1.00	1.00	1.00	1.00	1.00	1.00	1.00	1.00	1.00
Initial Bse:	65	140	140	490	245	70	25	2680	85	165	2585	410
Added Vol:	0	6	0	34	11	0	0	6	0	0	3	18
PasserByVol:	0	0	0	0	0	0	0	0	0	0	0	0
Initial Fut:	65	146	140	524	256	70	25	2686	85	165	2588	428
User Adj:	1.00	1.00	1.00	1.00	1.00	1.00	1.00	1.00	1.00	1.00	1.00	1.00
PHF Adj:	1.00	1.00	1.00	1.00	1.00	1.00	1.00	1.00	1.00	1.00	1.00	1.00
PHF Volume:	65	146	140	524	256	70	25	2686	85	165	2588	428
Reduct Vol:	0	0	0	0	0	0	0	0	0	0	0	0
Reduced Vol:	65	146	140	524	256	70	25	2686	85	165	2588	428
PCE Adj:	1.00	1.00	1.00	1.00	1.00	1.00	1.00	1.00	1.00	1.00	1.00	1.00
MLF Adj:	1.00	1.00	1.00	1.00	1.00	1.00	1.00	1.00	1.00	1.00	1.00	1.00
FinalVolume:	65	146	140	524	256	70	25	2686	85	165	2588	428

Saturation Flow Module:

Sat/Lane:	1900	1900	1900	1900	1900	1900	1900	1900	1900	1900	1900	1900
Adjustment:	0.92	1.00	0.92	0.92	1.00	0.92	0.92	0.98	0.95	0.92	1.00	0.92
Lanes:	1.00	2.00	1.00	1.00	2.00	1.00	1.00	2.90	0.10	1.00	3.00	1.00
Final Sat.:	1750	3800	1750	1750	3800	1750	1750	5428	172	1750	5700	1750

Capacity Analysis Module:

Vol/Sat:	0.04	0.04	0.08	0.30	0.07	0.04	0.01	0.49	0.49	0.09	0.45	0.24
Crit Moves:	****			****			****			****		
Green Time:	25.3	14.0	14.0	52.6	41.3	41.3	8.6	86.9	86.9	16.5	94.8	94.8
Volume/Cap:	0.25	0.47	0.97	0.97	0.28	0.16	0.28	0.97	0.97	0.97	0.81	0.44
Uniform Del:	64.0	74.4	77.8	57.9	52.2	50.7	77.7	40.3	40.3	76.5	30.5	22.0
IncrementDel:	0.5	1.1	65.1	30.7	0.2	0.2	1.8	10.5	10.5	59.4	1.7	0.3
InitQueueDel:	0.0	0.0	0.0	0.0	0.0	0.0	0.0	0.0	0.0	0.0	0.0	0.0
Delay Adj:	1.00	1.00	1.00	1.00	1.00	1.00	1.00	1.00	1.00	1.00	1.00	1.00
Delay/Veh:	64.5	75.5	142.8	88.6	52.4	50.9	79.5	50.8	50.8	135.9	32.2	22.3
User DelAdj:	1.00	1.00	1.00	1.00	1.00	1.00	1.00	1.00	1.00	1.00	1.00	1.00
AdjDel/Veh:	64.5	75.5	142.8	88.6	52.4	50.9	79.5	50.8	50.8	135.9	32.2	22.3
LOS by Move:	E	E-	F	F	D-	D	E-	D	D	F	C-	C+
HCM2kAvgQ:	3	4	11	34	5	3	1	45	45	9	34	13

\*\*\*\*\*  
 Note: Queue reported is the number of cars per lane.  
 \*\*\*\*\*

Level Of Service Computation Report  
 2000 HCM Operations Method (Future Volume Alternative)

\*\*\*\*\*  
 Intersection #13 Capitol Expressway/Aborn Road  
 \*\*\*\*\*

Cycle (sec): 190 Critical Vol./Cap.(X): 1.868  
 Loss Time (sec): 0 Average Delay (sec/veh): 246.0  
 Optimal Cycle: 180 Level Of Service: F  
 \*\*\*\*\*

Street Name:	Capitol Expresswa						Aborn Road									
Approach:	North Bound			South Bound			East Bound			West Bound						
Movement:	L	T	R	L	T	R	L	T	R	L	T	R				
Control:	Protected			Protected			Protected			Protected						
Rights:	Include			Include			Include			Include						
Min. Green:	7	10	10	7	10	10	7	10	10	7	10	10				
Y+R:	4.0	4.0	4.0	4.0	4.0	4.0	4.0	4.0	4.0	4.0	4.0	4.0				
Lanes:	1	0	4	0	1	2	0	3	1	0	1	2	0	2	0	1

Volume Module:

Base Vol:	205	1565	1555	960	1760	100	260	450	165	1295	525	920
Growth Adj:	1.00	1.00	1.00	1.00	1.00	1.00	1.00	1.00	1.00	1.00	1.00	1.00
Initial Bse:	205	1565	1555	960	1760	100	260	450	165	1295	525	920
Added Vol:	0	0	0	0	0	0	0	6	0	0	3	0
PasserByVol:	0	0	0	0	0	0	0	0	0	0	0	0
Initial Fut:	205	1565	1555	960	1760	100	260	456	165	1295	528	920
User Adj:	1.00	1.00	1.00	1.00	1.00	1.00	1.00	1.00	1.00	1.00	1.00	1.00
PHF Adj:	1.00	1.00	1.00	1.00	1.00	1.00	1.00	1.00	1.00	1.00	1.00	1.00
PHF Volume:	205	1565	1555	960	1760	100	260	456	165	1295	528	920
Reduct Vol:	0	0	0	0	0	0	0	0	0	0	0	0
Reduced Vol:	205	1565	1555	960	1760	100	260	456	165	1295	528	920
PCE Adj:	1.00	1.00	1.00	1.00	1.00	1.00	1.00	1.00	1.00	1.00	1.00	1.00
MLF Adj:	1.00	1.00	1.00	1.00	1.00	1.00	1.00	1.00	1.00	1.00	1.00	1.00
FinalVolume:	205	1565	1555	960	1760	100	260	456	165	1295	528	920

Saturation Flow Module:

Sat/Lane:	1900	1900	1900	1900	1900	1900	1900	1900	1900	1900	1900	1900
Adjustment:	0.92	1.00	0.92	0.83	0.99	0.95	0.92	1.00	0.92	0.83	1.00	0.92
Lanes:	1.00	4.00	1.00	2.00	3.78	0.22	1.00	2.00	1.00	2.00	2.00	1.00
Final Sat.:	1750	7600	1750	3150	7096	403	1750	3800	1750	3150	3800	1750

Capacity Analysis Module:

Vol/Sat:	0.12	0.21	0.89	0.30	0.25	0.25	0.15	0.12	0.09	0.41	0.14	0.53
Crit Moves:	****	****	****	****	****	****	****	****	****	****	****	****
Green Time:	38.9	90.4	90.4	31.0	82.5	82.5	15.1	15.5	15.5	53.1	53.5	53.5
Volume/Cap:	0.57	0.43	1.87	1.87	0.57	0.57	1.87	1.47	1.16	1.47	0.49	1.87
Uniform Del:	64.4	31.1	47.2	75.3	38.3	38.3	82.8	82.7	82.7	64.8	54.0	64.7
IncrementDel:	2.2	0.1	395.0	397.8	0.2	0.2	416.5	229	123.3	218.2	0.4	398.1
InitQueueDel:	0.0	0.0	0.0	0.0	0.0	0.0	0.0	0.0	0.0	0.0	0.0	0.0
Delay Adj:	1.00	1.00	1.00	1.00	1.00	1.00	1.00	1.00	1.00	1.00	1.00	1.00
Delay/Veh:	66.6	31.2	442.2	473.1	38.6	38.6	499.4	311	206.0	283.0	54.3	462.8
User DelAdj:	1.00	1.00	1.00	1.00	1.00	1.00	1.00	1.00	1.00	1.00	1.00	1.00
AdjDel/Veh:	66.6	31.2	442.2	473.1	38.6	38.6	499.4	311	206.0	283.0	54.3	462.8
LOS by Move:	E	C	F	F	D+	D+	F	F	F	F	D-	F
HCM2kAvgQ:	10	13	184	65	19	19	32	23	15	71	11	109

\*\*\*\*\*  
 Note: Queue reported is the number of cars per lane.  
 \*\*\*\*\*

Level Of Service Computation Report  
 2000 HCM Operations Method (Future Volume Alternative)

\*\*\*\*\*  
 Intersection #14 Capitol Expressway/Silver Creek Road  
 \*\*\*\*\*

Cycle (sec): 190 Critical Vol./Cap.(X): 0.949  
 Loss Time (sec): 0 Average Delay (sec/veh): 55.2  
 Optimal Cycle: 180 Level Of Service: E+

Street Name:	Capitol Expresswa						Silver Creek Road					
Approach:	North Bound			South Bound			East Bound			West Bound		
Movement:	L	T	R	L	T	R	L	T	R	L	T	R
Control:	Protected			Protected			Protected			Protected		
Rights:	Include			Include			Include			Include		
Min. Green:	7	10	10	7	10	10	7	10	10	7	10	10
Y+R:	4.0	4.0	4.0	4.0	4.0	4.0	4.0	4.0	4.0	4.0	4.0	4.0
Lanes:	2	0	4	0	1	2	0	4	0	1	2	0

Volume Module:

Base Vol:	685	3060	530	250	2935	55	100	410	395	365	325	140
Growth Adj:	1.00	1.00	1.00	1.00	1.00	1.00	1.00	1.00	1.00	1.00	1.00	1.00
Initial Bse:	685	3060	530	250	2935	55	100	410	395	365	325	140
Added Vol:	0	0	20	0	0	0	0	6	0	11	3	0
PasserByVol:	0	0	0	0	0	0	0	0	0	0	0	0
Initial Fut:	685	3060	550	250	2935	55	100	416	395	376	328	140
User Adj:	1.00	1.00	1.00	1.00	1.00	1.00	1.00	1.00	1.00	1.00	1.00	1.00
PHF Adj:	1.00	1.00	1.00	1.00	1.00	1.00	1.00	1.00	1.00	1.00	1.00	1.00
PHF Volume:	685	3060	550	250	2935	55	100	416	395	376	328	140
Reduct Vol:	0	0	0	0	0	0	0	0	0	0	0	0
Reduced Vol:	685	3060	550	250	2935	55	100	416	395	376	328	140
PCE Adj:	1.00	1.00	1.00	1.00	1.00	1.00	1.00	1.00	1.00	1.00	1.00	1.00
MLF Adj:	1.00	1.00	1.00	1.00	1.00	1.00	1.00	1.00	1.00	1.00	1.00	1.00
FinalVolume:	685	3060	550	250	2935	55	100	416	395	376	328	140

Saturation Flow Module:

Sat/Lane:	1900	1900	1900	1900	1900	1900	1900	1900	1900	1900	1900	1900
Adjustment:	0.83	1.00	0.92	0.83	1.00	0.92	0.83	1.00	0.92	0.83	0.98	0.95
Lanes:	2.00	4.00	1.00	2.00	4.00	1.00	2.00	2.00	1.00	2.00	1.39	0.61
Final Sat.:	3150	7600	1750	3150	7600	1750	3150	3800	1750	3150	2592	1106

Capacity Analysis Module:

Vol/Sat:	0.22	0.40	0.31	0.08	0.39	0.03	0.03	0.11	0.23	0.12	0.13	0.13
Crit Moves:	****			****			****		****	****		
Green Time:	43.6	101	101.0	19.9	77.3	77.3	16.2	45.2	45.2	23.9	52.9	52.9
Volume/Cap:	0.95	0.76	0.59	0.76	0.95	0.08	0.37	0.46	0.95	0.95	0.45	0.45
Uniform Del:	68.3	33.1	28.8	78.3	51.6	32.7	77.7	58.7	67.5	78.1	53.7	53.7
IncrementDel:	21.8	0.9	1.0	9.7	7.5	0.0	0.9	0.2	19.4	32.2	0.3	0.3
InitQueueDel:	0.0	0.0	0.0	0.0	0.0	0.0	0.0	0.0	0.0	0.0	0.0	0.0
Delay Adj:	1.00	1.00	1.00	1.00	1.00	1.00	1.00	1.00	1.00	1.00	1.00	1.00
Delay/Veh:	90.1	33.9	29.8	88.1	59.0	32.7	78.6	58.9	86.9	110.3	54.0	54.0
User DelAdj:	1.00	1.00	1.00	1.00	1.00	1.00	1.00	1.00	1.00	1.00	1.00	1.00
AdjDel/Veh:	90.1	33.9	29.8	88.1	59.0	32.7	78.6	58.9	86.9	110.3	54.0	54.0
LOS by Move:	F	C-	C	F	E+	C-	E-	E+	F	F	D-	D-
HCM2kAvgQ:	26	33	22	8	41	2	3	10	27	16	11	11

\*\*\*\*\*  
 Note: Queue reported is the number of cars per lane.  
 \*\*\*\*\*

-----  
 Scenario Report  
 Scenario: Cumulative Plus Project PM

Command: Default Command  
 Volume: Future PM  
 Geometry: Existing  
 Impact Fee: Default Impact Fee  
 Trip Generation: Project PM  
 Trip Distribution: Project  
 Paths: Project  
 Routes: Default Route  
 Configuration: Default Configuration

-----  
 Impact Analysis Report  
 Level Of Service

Intersection		Base		Future		Change in
		Del/	V/	Del/	V/	
		LOS Veh	C	LOS Veh	C	
# 6 San Felipe Road/Yerba Buena Ro	D	45.6	0.924	D-	51.7 0.976	+ 6.092 D/V
# 11 Aborn Road/White Road/San Feli	E+	58.5	0.957	E	60.5 0.971	+ 2.023 D/V

-----  
 Level of Service Computation Report  
 2000 HCM Operations Method (Future Volume Alternative)  
 \*\*\*\*\*  
 Intersection #6 San Felipe Road/Yerba Buena Road  
 \*\*\*\*\*  
 Cycle (sec): 120 Critical Vol./Cap.(X): 0.976  
 Loss Time (sec): 0 Average Delay (sec/veh): 51.7  
 Optimal Cycle: 180 Level of Service: D-  
 \*\*\*\*\*  
 Street Name: San Felipe Road Yerba Buena Road  
 Approach: North Bound South Bound East Bound West Bound  
 Movement: L - T - R L - T - R L - T - R L - T - R  
 -----  
 Control: Protected Protected Protected Protected  
 Rights: Include Include Include Include  
 Min. Green: 7 10 10 7 10 10 7 10 10 7 10 10  
 Y+R: 4.0 4.0 4.0 4.0 4.0 4.0 4.0 4.0 4.0 4.0 4.0 4.0  
 Lanes: 2 0 2 0 1 1 0 2 0 1 2 0 2 0 1 1 0 2 0 1  
 -----  
 Volume Module:  
 Base Vol: 215 425 155 300 455 520 595 1545 350 210 1405 315  
 Growth Adj: 1.00 1.00 1.00 1.00 1.00 1.00 1.00 1.00 1.00 1.00 1.00 1.00  
 Initial Bse: 215 425 155 300 455 520 595 1545 350 210 1405 315  
 Added Vol: 0 13 13 43 7 36 68 68 0 7 36 26  
 PasserByVol: 0 0 0 0 0 0 0 0 0 0 0 0  
 Initial Fut: 215 438 168 343 462 556 663 1613 350 217 1441 341  
 User Adj: 1.00 1.00 1.00 1.00 1.00 1.00 1.00 1.00 1.00 1.00 1.00 1.00  
 PHF Adj: 1.00 1.00 1.00 1.00 1.00 1.00 1.00 1.00 1.00 1.00 1.00 1.00  
 PHF Volume: 215 438 168 343 462 556 663 1613 350 217 1441 341  
 Reduct Vol: 0 0 0 0 0 0 0 0 0 0 0 0  
 Reduced Vol: 215 438 168 343 462 556 663 1613 350 217 1441 341  
 PCE Adj: 1.00 1.00 1.00 1.00 1.00 1.00 1.00 1.00 1.00 1.00 1.00 1.00  
 MLF Adj: 1.00 1.00 1.00 1.00 1.00 1.00 1.00 1.00 1.00 1.00 1.00 1.00  
 FinalVolume: 215 438 168 343 462 556 663 1613 350 217 1441 341  
 -----  
 Saturation Flow Module:  
 Sat/Lane: 1900 1900 1900 1900 1900 1900 1900 1900 1900 1900 1900 1900  
 Adjustment: 0.83 1.00 0.92 0.92 1.00 0.92 0.83 1.00 0.92 0.92 1.00 0.92  
 Lanes: 2.00 2.00 1.00 1.00 2.00 1.00 2.00 2.00 1.00 1.00 2.00 1.00  
 Final Sat.: 3150 3800 1750 1750 3800 1750 3150 3800 1750 1750 3800 1750  
 -----  
 Capacity Analysis Module:  
 Vol/Sat: 0.07 0.12 0.10 0.20 0.12 0.32 0.21 0.42 0.20 0.12 0.38 0.19  
 Crit Moves: \*\*\*\* \*\*\*\* \*\*\*\*  
 Green Time: 8.4 17.6 17.6 29.9 39.1 39.1 25.9 56.1 56.1 16.4 46.6 46.6  
 Volume/Cap: 0.98 0.79 0.66 0.79 0.37 0.98 0.98 0.91 0.43 0.91 0.98 0.50  
 Uniform Del: 55.7 49.4 48.4 42.1 31.1 40.0 46.7 29.5 21.2 51.1 36.1 27.9  
 IncremntDel: 53.5 7.3 6.0 9.2 0.2 31.4 28.4 7.2 0.4 34.4 17.9 0.6  
 InitQueueDel: 0.0 0.0 0.0 0.0 0.0 0.0 0.0 0.0 0.0 0.0 0.0 0.0  
 Delay Adj: 1.00 1.00 1.00 1.00 1.00 1.00 1.00 1.00 1.00 1.00 1.00 1.00  
 Delay/Veh: 109.2 56.7 54.4 51.3 31.3 71.4 75.1 36.7 21.6 85.5 54.0 28.4  
 User DelAdj: 1.00 1.00 1.00 1.00 1.00 1.00 1.00 1.00 1.00 1.00 1.00 1.00  
 AdjDel/Veh: 109.2 56.7 54.4 51.3 31.3 71.4 75.1 36.7 21.6 85.5 54.0 28.4  
 LOS by Move: F E+ D- D- C E E- D+ C+ F D- C  
 HCM2kAvgQ: 8 10 7 15 6 28 15 26 9 12 32 10

\*\*\*\*\*  
 Note: Queue reported is the number of cars per lane.  
 \*\*\*\*\*

-----  
 Level of Service Computation Report  
 2000 HCM Operations Method (Future Volume Alternative)  
 \*\*\*\*\*  
 Intersection #11 Aborn Road/White Road/San Felipe Road  
 \*\*\*\*\*  
 Cycle (sec): 155 Critical Vol./Cap.(X): 0.971  
 Loss Time (sec): 0 Average Delay (sec/veh): 60.5  
 Optimal Cycle: 180 Level of Service: E  
 \*\*\*\*\*  
 Street Name: San Felipe Road Aborn Road  
 Approach: North Bound South Bound East Bound West Bound  
 Movement: L - T - R L - T - R L - T - R L - T - R  
 -----  
 Control: Protected Protected Protected Protected  
 Rights: Include Include Include Include  
 Min. Green: 7 10 10 7 10 10 7 10 10 7 10 10  
 Y+R: 4.0 4.0 4.0 4.0 4.0 4.0 4.0 4.0 4.0 4.0 4.0 4.0  
 Lanes: 2 0 2 0 1 2 0 2 0 1 2 0 3 0 1 2 0 3 0 1  
 -----  
 Volume Module:  
 Base Vol: 530 835 135 255 1040 400 535 1795 565 310 1970 280  
 Growth Adj: 1.00 1.00 1.00 1.00 1.00 1.00 1.00 1.00 1.00 1.00 1.00 1.00  
 Initial Bse: 530 835 135 255 1040 400 535 1795 565 310 1970 280  
 Added Vol: 21 13 8 0 25 0 0 0 40 15 0 0  
 PasserByVol: 0 0 0 0 0 0 0 0 0 0 0 0  
 Initial Fut: 551 848 143 255 1065 400 535 1795 605 325 1970 280  
 User Adj: 1.00 1.00 1.00 1.00 1.00 1.00 1.00 1.00 1.00 1.00 1.00 1.00  
 PHF Adj: 1.00 1.00 1.00 1.00 1.00 1.00 1.00 1.00 1.00 1.00 1.00 1.00  
 PHF Volume: 551 848 143 255 1065 400 535 1795 605 325 1970 280  
 Reduct Vol: 0 0 0 0 0 0 0 0 0 0 0 0  
 Reduced Vol: 551 848 143 255 1065 400 535 1795 605 325 1970 280  
 PCE Adj: 1.00 1.00 1.00 1.00 1.00 1.00 1.00 1.00 1.00 1.00 1.00 1.00  
 MLF Adj: 1.00 1.00 1.00 1.00 1.00 1.00 1.00 1.00 1.00 1.00 1.00 1.00  
 FinalVolume: 551 848 143 255 1065 400 535 1795 605 325 1970 280  
 -----  
 Saturation Flow Module:  
 Sat/Lane: 1900 1900 1900 1900 1900 1900 1900 1900 1900 1900 1900 1900  
 Adjustment: 0.83 1.00 0.92 0.83 1.00 0.92 0.83 1.00 0.92 0.83 1.00 0.92  
 Lanes: 2.00 2.00 1.00 2.00 2.00 1.00 2.00 3.00 1.00 2.00 3.00 1.00  
 Final Sat.: 3150 3800 1750 3150 3800 1750 3150 5700 1750 3150 5700 1750  
 -----  
 Capacity Analysis Module:  
 Vol/Sat: 0.17 0.22 0.08 0.08 0.28 0.23 0.17 0.31 0.35 0.10 0.35 0.16  
 Crit Moves: \*\*\*\* \*\*\*\* \*\*\*\* \*\*\*\*  
 Green Time: 27.9 53.3 53.3 19.3 44.8 44.8 27.1 63.4 63.4 18.9 55.2 55.2  
 Volume/Cap: 0.97 0.65 0.24 0.65 0.97 0.79 0.97 0.77 0.85 0.85 0.97 0.45  
 Uniform Del: 63.1 42.9 36.3 64.6 54.5 50.8 63.5 39.5 41.4 66.6 49.1 38.3  
 IncremntDel: 30.3 1.2 0.2 3.8 20.3 8.3 30.9 1.6 9.1 15.7 13.7 0.5  
 InitQueueDel: 0.0 0.0 0.0 0.0 0.0 0.0 0.0 0.0 0.0 0.0 0.0 0.0  
 Delay Adj: 1.00 1.00 1.00 1.00 1.00 1.00 1.00 1.00 1.00 1.00 1.00 1.00  
 Delay/Veh: 93.4 44.1 36.5 68.4 74.8 59.1 94.4 41.1 50.5 82.3 62.8 38.8  
 User DelAdj: 1.00 1.00 1.00 1.00 1.00 1.00 1.00 1.00 1.00 1.00 1.00 1.00  
 AdjDel/Veh: 93.4 44.1 36.5 68.4 74.8 59.1 94.4 41.1 50.5 82.3 62.8 38.8  
 LOS by Move: F D D+ E E E+ F D D F E D+  
 HCM2kAvgQ: 18 17 5 8 30 20 15 23 26 11 36 11  
 -----

\*\*\*\*\*  
 Note: Queue reported is the number of cars per lane.  
 \*\*\*\*\*

**APPENDIX C:  
APPROVED & PENDING PROJECTS**



**Trip Generation Estimates  
Approved and Cumulative Projects**

Zone No.	Project No.	Project	Location	Description	Land Use	ITE Code	Size	Unit	AM Peak Hour Trips				PM Peak Hour Trips			
									Rate	In	Out	Total	Rate	In	Out	Total
2	8	PDC03-015	Chisin St E/O Yerba Buena Rd	21 SF detached	Single-Family Detached Housing	210	21	DU	0.75	4	12	16	1.01	13	8	21
3	8	PDC04-098	San Felipe Rd S/O Yerba Buena Ave	9 SF attached	Residential Condo / Townhouse	230	9	DU	0.44	1	3	4	0.52	3	2	5
4	8	PDC05-048	Fowler Rd & Yerba Buena Rd	550 SF attached	Residential Condo / Townhouse	230	550	DU	0.44	41	201	242	0.52	192	94	286
4				550 SF detached	Single-Family Detached Housing	210	550	DU	0.75	103	309	413	1.01	350	206	556
5	8	PDC05-049	Yerba Buena Rd E/O Verona	225 SF detached, 1 ac park	Single-Family Detached Housing	210	225	DU	0.75	42	127	169	1.01	143	84	227
6	8	PDC05-052	Yerba Buena Rd & Old Yerba Buena Rd	675 SF detached, 39 ac open space	Single-Family Detached Housing	210	675	DU	0.75	127	380	506	1.01	430	252	682
7	8	PDC05-053	Yerba Buena Rd E/O San Felipe	500 res. Units, 1 ac open space	Single-Family Detached Housing	210	500	DU	0.75	94	281	375	1.01	318	187	505
7				195 KSF commercial/office	General Office Building	710	195	KSF	1.55	266	36	302	1.49	49	241	291
8	8	PDC09-010	Cadwallader Ave S/O Prunetree	40 SF detached	Single-Family Detached Housing	210	40	DU	0.75	8	23	30	1.01	25	15	40
9	8	PDC09-020	S/O Evergreen Vilage Square	35 SF attached	Residential Condo / Townhouse	230	35	DU	0.44	3	13	15	0.52	12	6	18
10	8	PDC10-001	Ruby Ave & Aborn Rd	103 SF detached	Single-Family Detached Housing	210	103	DU	0.75	19	58	77	1.01	66	38	104
10				15 KSF Retail	Shopping Center	820	15	KSF	1.03	9	6	15	3.75	27	29	56
11	8	PDC99-098	Fowler Rd & Altia Ave	1237.559 KSF campus industrial	Industrial Park	130	1,238	KSF	0.84	852	187	1040	0.86	224	841	1064

Notes:  
Trip generation average rates from ITE's *Trip Generation*, 7th Edition.

Sources: City of San Jose, 2011; Fehr & Peers, 2011